

MHI
Copy 3

*1 superseded
by
Aug 78*

FM 6-15

DEPARTMENT OF THE ARMY FIELD MANUAL

ARTILLERY METEOROLOGY

PROPERTY OF
QUARTERMASTER SCHOOL, FORT
U. S. Army
METEOROLOGY



HEADQUARTERS, DEPARTMENT OF THE ARMY

MARCH 1970

CHANGE }
No. 1 }

HEADQUARTERS
DEPARTMENT OF THE ARMY
WASHINGTON, D.C., 30 April 1971

ARTILLERY METEOROLOGY

FM 6-15, 25 March 1970, is changed as follows:

1. This change should not be posted to the basic manual until directed by CINCUSAREUR, CINCUSARPAC, CGUSCONARC, CGUSARAL, CGUSAEIGHT, or CGUSARV in accordance with instructions in DA message, subject: Implementation of NATO Standardization Agreements (STANAGS) 4061 (Edition No. 3) and 4082, 172152 February 1971.

2. Remove old pages and insert new pages as indicated:

<i>Old Pages—</i>	<i>New Pages—</i>
23 and 24	23 and 24
29 and 30	29 and 30
35 and 36	35 and 36
55 and 56	55 and 56
97 through 100	97 through 100
103 and 104	103 and 104
107 through 110	107 through 110
113 through 118	113 through 118.1
123 through 126	123 through 126
129 and 130	129 through 130
139 through 150	139 through 150.1
157 and 158	157 and 158
163 through 176	163 through 176
201 and 202	201 and 202
209 and 210	209 and 210
213 through 220	213 through 220
229 through 236	229 through 236.2
283 and 284	283 and 284
Figure 79, 79 cont, 89, 89 cont, and 101	Figure 79, 79 cont, 89, 89 cont, and 101.

3. New or changed material is indicated by a star.

4. File this change sheet in front of the manual for reference purposes.

By Order of the Secretary of the Army:

W. C. WESTMORELAND,
General, United States Army,
Chief of Staff.

Official:

VERNE L. BOWERS,
Major General, United States Army,
The Adjutant General.

Distribution:

To be distributed in accordance with DA Form 12-11 requirements for Artillery Meteorology and Tables.

ARTILLERY METEOROLOGY

	Paragraphs	Page
PART ONE. GENERAL		
CHAPTER 1. INTRODUCTION	1, 2	3
2. ELEMENTARY METEOROLOGY		
Section I. General	3-6	4
II. The earth's atmosphere	7-14	5
III. Air masses and frontal activity	15-18	15
IV. Synoptic weather	19-22	20
CHAPTER 3. METEOROLOGICAL REQUIREMENTS OF THE FIELD ARMY	23-28	24
CHAPTER 4. ORGANIZATION, MISSION, CAPABILITIES, AND LIMITATIONS OF THE ARTILLERY METEOROLOGICAL SECTION	29-35	32
CHAPTER 5. ADDITIONAL SOURCES OF METEOROLOGICAL INFORMATION	36-40	37
PART TWO. BALLISTIC METEOROLOGY		
CHAPTER 6. METEOROLOGICAL OBSERVATION EQUIPMENT		
Section I. Station, manual AN/TMQ-4	41-48	39
II. Surface observation equipment	49-54	51
III. Inflation equipment and balloons	57-67	56
IV. Plotting and communications equipment	68-69	66
V. Rawinsonde system	70-71	68
VI. Radiosondes	72-74	70
VII. Rawin set AN/GMD-1()	75-80	75
VIII. Radiosonde recorder AN/TMQ-5()	81-87	83
IX. Calibration equipment	88-90	85
X. Power units	91-92	89
CHAPTER 7. OBSERVATIONS TECHNIQUES		
Section I. Organization of teams	93-98	93
II. Selection and occupation of position	99-104	94
III. Team duties before balloon release	105-117	98
IV. Team duties during balloon release	118-120	110
V. Duties of temperature-density team during flight	121-144	110
VI. Duties of ballistic winds team after balloon release	145-151	151
CHAPTER 8. ENCODING AND TRANSMISSION OF ARTILLERY MET MESSAGES	152-160	164
9. DETERMINATION OF NATO DENSITIES AND TEMPERATURES FROM SURFACE OBSERVATIONS	161-165	176
10. DETERMINATION OF NATO WINDS FROM OBSERVATION OF PILOT BALLOONS	166-169	183
11. VALIDITY OF ARTILLERY METEORO- LOGICAL MESSAGES	170-174	195
PART THREE. METEOROLOGY FOR SOUND RANGING		
CHAPTER 12. PRINCIPLES OF SOUND RANGING	175-177	197
13. SOUND RANGING MESSAGE DEVELOPED FROM RADIOSONDE DATA	178-182	199
14. SOUND RANGING MESSAGE DEVELOPED FROM SURFACE AND PILOT BALLOON OBSERVATIONS	183-186	204

	Paragraphs	Page
PART FOUR. METEOROLOGY FOR FALLOUT PREDICTION		
CHAPTER 15. GENERAL	187-188	209
16. FALLOUT METEOROLOGICAL REQUIREMENTS	189-191	210
17. DETERMINATION OF HIGH-ALTITUDE WINDS	192-195	211
18. DETERMINATION OF THE TROPOPAUSE	196-198	214
19. ENCODING AND TRANSMISSION OF FALLOUT METEOROLOGICAL MESSAGE ..	199-200	218
PART FIVE. AIR WEATHER SERVICE		
CHAPTER 20. ORGANIZATION AND MISSION OF THE AIR WEATHER SERVICE WITH THE U.S. ARMY		
Section I. Introduction	201-205	221
II. Air Weather Service Support Function and Organization With the Army	206-209	222
CHAPTER 21. WEATHER FORECAST CAPABILITIES AND LIMITATIONS OF THE AIR WEATHER SERVICE	210-213	228
22. ENCODING AND EXCHANGE OF METEOROLOGICAL DATA BETWEEN AIR WEATHER SERVICE AND ARMY ARTILLERY	214-221	230
PART SIX. SPECIAL APPLICATIONS AND MISCELLANEOUS OPERATIONS		
CHAPTER 23. MEASUREMENT OF LOW-LEVEL WINDS FOR FREE ROCKETS	222-224	239
24. ARCTIC AND JUNGLE OPERATIONS		
Section I. Arctic operations	225-226	247
II. Jungle operations	227-229	248
CHAPTER 25. DETERMINATION OF TEMPERATURE AND HUMIDITY INDEX	230-234	250
26. DETERMINATION OF WIND CHILL FACTOR ..	235-236	253
27. INSPECTIONS AND INSPECTION CHECKLISTS		
Section I. General	237-239	255
Section II. Command inspections	240-242	256
CHAPTER 28. DETERMINATION OF PRESSURE ALTITUDES	243-246	260
29. DECONTAMINATION OF EQUIPMENT	247-249	263
30. DESTRUCTION OF EQUIPMENT	250-252	264
31. SAFETY PRECAUTIONS	253-255	265
32. QUALIFICATION TESTS FOR METEOROLOGICAL SPECIALISTS	256-281	267
APPENDIX A. REFERENCES		281
B. INSPECTION CHECKLISTS		284
GLOSSARY.		287
INDEX.		292

PART ONE
GENERAL
CHAPTER 1
INTRODUCTION

1. Purpose and Scope

a. Purpose. This manual is concerned with the meteorological needs of the artillery. It describes the sources of meteorological data within the field army and describes in detail how these data are developed. This manual also describes other meteorological data peculiar to the needs of the field army.

b. Scope. This manual covers the ballistic meteorological problem and the method of determining ballistic densities, temperatures, and winds. It presents the techniques of measuring and reporting low-level winds for fallout prediction, measuring low-level winds and temperature for sound ranging, and measuring low-level winds for rockets. It describes the organization of the Air Weather Service within the field army and describes the manner in which artillery meteorological units support the Air Weather Service. Operations of meteorological units under extremes of weather are described. The method of measuring the temperature-humidity index is described. It also describes maintenance, inspection, decontamination, necessary destruction of equipment, and safety precautions for meteorological sec-

tions and equipment. The material presented herein is applicable without modification to both nuclear and nonnuclear warfare. It is in consonance with those international agreements listed in paragraph 7, Appendix A. Within this manual the term "artillery" is used to mean both field artillery and air defense artillery with exact meaning indicated by the context. Forms prescribed for use in this manual are available through normal AG publications supply channels.

2. Changes or Corrections

Users of this manual are encouraged to submit recommended changes and comments to improve the publication. Comments should be keyed to the specific page, paragraph, and line of the text in which the change is recommended. Reasons will be provided for each comment to insure understanding and complete evaluation. Comments should be prepared using DA Form 2028 (Recommended Changes to Publications) and forwarded direct to Commandant, United States Army Field Artillery School, ATTN: AKPSIAS-PL-FM, Fort Sill, Oklahoma 73503.

CHAPTER 2

ELEMENTARY METEOROLOGY

Section I. GENERAL

3. Introduction

Meteorology of the weather-adage type is at least as old as the Bible; however, extensive knowledge of actual behavior of the atmosphere has been acquired rather slowly through the centuries. Meteorology as a science was actually founded about 100 years ago by the French astronomer, Le Venier. The science of meteorology has advanced significantly since World War I. Some fundamentals of meteorology are discussed in this chapter to provide the artillery meteorologist with a basic understanding of weather.

4. Definition

Meteorology is defined as the science dealing with the atmospheric phenomena. In addition to the physics, chemistry, and dynamics of the atmosphere, meteorology includes many of the direct effects of the atmosphere upon the earth's surface, the oceans, and life in general.

5. Significance of Meteorology to the Army

The employment of rockets and missiles, the necessary dispersion of ground forces, the rapid displacement of both men and materiel on the nuclear battlefield, and the efficient use of nuclear weapons are all affected by the weather. There is an urgent requirement for meteorological information within the field army, and accurate meteorological information must be obtained in more detail over increasing areas for dissemination to all commands. The accomplishment of this task is a joint responsibility of the Air Weather Service of the U.S. Air Force and the meteorological services organic to the field army. The discharge of this joint responsibility is directed by AR 115-10/AFR 105-3. The artillery meteorologist is not expected to make weather forecasts since forecasting is an Air Weather Service responsibility. However, he should be able to distinguish

major types and changes of weather which will affect the validity of a meteorological message.

6. The Sun and the Earth

The sun is the original source of heat energy for both the surface of the earth and the earth's atmosphere. All changes and motions in the atmosphere are caused directly or indirectly by the energy radiated from the sun. There are two motions of the earth which affect the weather. First, the rotation of the earth on its axis each 24 hours causes day and night and produces the major wind belts of the earth. Second, the earth revolves in an elliptical orbit about the sun at a velocity of 29.8 kilometers per second, making one complete revolution per year. The average distance between the sun and earth is approximately 148,993,400 kilometers, being least in December and greatest in June. The seasons result from the fact that the axis on which the earth rotates is tilted at an angle of $23\frac{1}{2}^{\circ}$ from a perpendicular to the plane of the earth's orbit. During the northern hemispheric summer, the North Pole tilts toward the sun and days lengthen for all locations in the Northern Hemisphere. During the northern hemispheric winter, the North Pole points away from the sun and colder temperatures prevail owing to the shorter duration of sunshine and the effect of the sun's rays striking the earth at a more acute angle. Twice a year, during the fall and spring equinoxes, the sun's rays fall equally on both hemispheres with day and night of equal duration everywhere on the earth. During the year (365 $\frac{1}{4}$ days), the earth loses approximately the same amount of heat it receives from the sun. During the spring, the Northern Hemisphere gains more heat than it loses. This accumulation of heat continues until late July, when maximum warmth is reached, then slowly diminishes until late August. During the fall, the northern hemisphere loses more heat

than it receives and begins to cool. The entire process is like starting a fire in a stove. Initially the roaring fire heats the room rather slowly, but the room remains warm for a considerable time after

the fire has died down. This heat lag phenomenon also accounts for the fact that the warmest time of day is usually about 1500 hours and not at noon when the sun's rays are most direct.

Section II. THE EARTH'S ATMOSPHERE

7. Composition

a. The earth's atmosphere is a mixture of transparent gases extending from the surface of the earth upward. Its exact upper limit is not known but is estimated to be well above 1,000 kilometers. The composition of this sea of air, which clings to the earth's surface because of the force of gravity, is nearly uniform from place to place throughout the world, with the exception of its moisture content. This is to be expected, since continual mixing occurs as the wind blows, and the surface is heated by the sun, then allowed to cool. Rather surprising though is the fact that this mixture is nearly constant up to 80 kilometers, the beginning of the thermosphere. The atmosphere thins out with elevation so rapidly that approximately one-half of its weight is packed into the lower 6 kilometers.

b. The two most abundant gases of dry air are nitrogen, which accounts for nearly four-fifths of the total, and oxygen, which accounts for the other one-fifth. Carbon dioxide, argon, ozone, and various other gases make up approximately 1 percent of the permanent gases of the atmosphere. The air encountered in nature also contains a variable amount of invisible water vapor which is normally concentrated in the lower part of the atmosphere. From the standpoint of weather, water vapor is the most important constituent of the atmosphere. Clouds, fog, rain, and snow can form only as a result of this vapor changing into water droplets or ice crystals. The atmosphere also contains literally billions of minute foreign particles, such as dust, combustion products, and salt from sea spray. These particles are referred to as condensation nuclei due to the condensation of water vapor upon them to form clouds and fog. The majority of these solid particles are microscopic salt crystals suspended in the lower layers of the atmosphere.

8. Vertical Structure of the Atmosphere

The atmosphere is normally depicted on charts as being divided into layers, each of which possesses certain distinctive characteristics. Thermal characteristics are used, in this manual, to divide the

atmospheric model (fig 1) into layers. The data above 20 kilometers, while not official, are taken from a Department of Commerce document known as the U.S. Extension to the ICAO Standard Atmosphere.

a. *Troposphere.* The turbulent layer nearest the surface of the earth, in which practically all storms and clouds occur, is called the troposphere. This layer contains most of the mass of the atmosphere (about three-fourths) and is characterized by an approximately linear decrease of temperature with height. The thickness of the troposphere varies with the season of the year, the latitude, and the current weather situation, the average thickness being about 18 kilometers in equatorial regions and 8 kilometers in polar regions. The rate of decrease of temperature with height is known as the lapse rate. The standard tropospheric lapse rate is about 6.5° Celsius (Centigrade) per kilometer, but, on a particular occasion, the lapse rate may differ considerably from the standard.

Note. This lapse rate was agreed upon at the Ninth General Conference on Weights and Measures in 1948 and under standard conditions is defined in the Glossary of Meteorology.

Strong vertical and horizontal movements of air are developed within the troposphere with wind speed generally increasing with height. The top of the troposphere is known as the tropopause, and it defines a boundary above which normal convective activity is restricted. The tropopause is usually identified by a temperature of about minus 56° Celsius and a significant change in lapse rate. The tropopause was once thought to be continuous from the equator to the poles but it is now known to have occasional breaks and overlaps resulting in a multiple tropopause in some instances. These breaks are important in connection with jet streams, paths of high-velocity winds, which are usually located near these discontinuities in the tropopause. Jet streams, discovered during World War II, may contain winds of 220 knots or more at their core.

b. *Stratosphere.* The layer immediately above

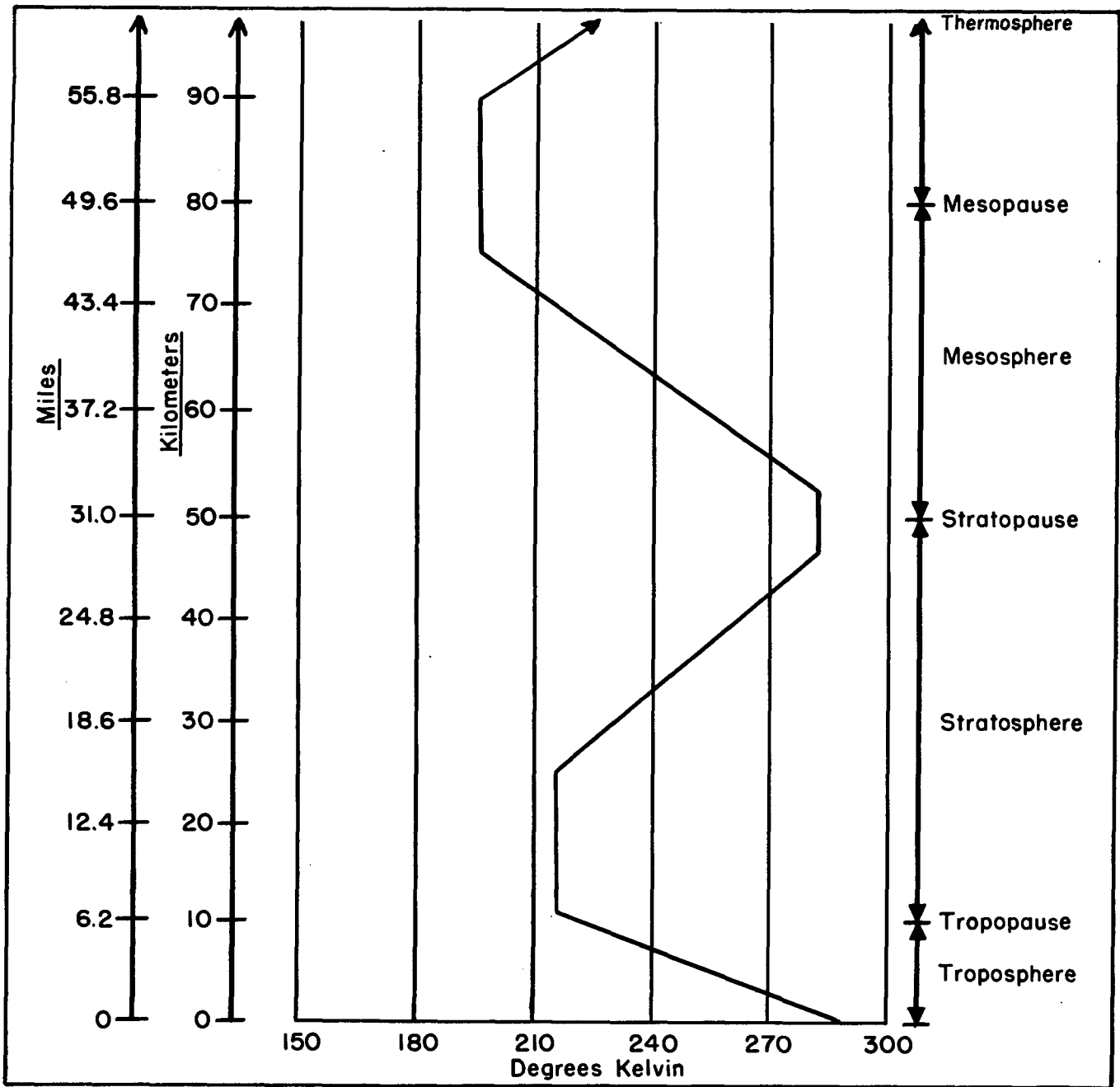

This chart is based on NATO STANAG 4044 (1958). ICAO up to 20 kilometers; U.S. Ext. to ICAO above 20 kilometers.

Figure 1. Thermal structure of the atmosphere.

the tropopause is called the stratosphere and is characterized by an almost complete lack of clouds and by relatively little turbulence. There is sufficient mixing in the stratosphere, however, to prevent the heavier gases from concentrating near the bottom. The lower part of the strato-

sphere, from the tropopause up to about 25 kilometers, is characterized by a slight increase of temperature with height (inversion) or by an essentially isothermal lapse rate. Within the upper part of the stratosphere, the temperature rises about 5° Celsius per kilometer and reaches a

peak in the vicinity of 50 kilometers. This warm region lies near the top of a thick layer containing ozone and is the result of absorption of ultraviolet radiation from the sun by the ozone. The total ozone in the atmosphere at normal sea level temperature and pressure would form a layer only 3 centimeters thick. The temperature at the stratopause (or top of the stratosphere) is roughly equivalent to that at the earth's surface.

c. Mesosphere. The mesosphere lies above the stratosphere and is a turbulent layer in which the temperature decreases with height. The temperature at the top of the mesosphere, known as the mesopause, is colder than that at the tropopause, reaching a minimum of approximately minus 100° Celsius. Noctilucent clouds, the highest clouds known, are formed near the mesopause. The relentless bombardment of the thinly scattered air molecules by radiation from the sun causes noticeable ionization within this layer of the atmosphere. The lowest of these ionized regions is known as the D region and has the ability to reflect low frequency radio waves. The ion density of these regions generally increases with height above 60 kilometers and goes through a large diurnal variation.

d. Thermosphere. The layer immediately above the mesopause is called the thermosphere. Temperature in this layer increases with height and may have a negative lapse rate (inversion) as great as 20° Celsius per kilometer. Rocket research vehicles indicate that the temperature may reach 2,300° Celsius at the thermopause, the top of the thermosphere. Oxygen molecules in the thermosphere are gradually dissociated into oxygen atoms by energy from the sun. Gases in this upper region are not well mixed and several bands of ionized air are known to exist in the thermosphere. The phenomenon in the Northern Hemisphere known as the aurora borealis, or northern lights, occurs in the thermosphere. The auroras are believed to be produced by an influx of charged particles from the sun which collide with oxygen and nitrogen molecules; the excitation of the molecules causes them to emit light.

9. Transfer of Heat in the Atmosphere

The source of the earth's energy is the sun, which emits both heat and light much the same as an electric radiant heater. This radiant energy from the sun travels with the speed of light for approximately 148,000,000 kilometers through space to the earth. The energy which reaches the earth is partially reflected back into space and partially absorbed. The absorbed energy is con-

verted into heat, which is used by the earth-atmosphere system. An important fact is that the sun's energy warms the earth's surface without appreciably heating the bulk of the earth's atmosphere through which it passes. The distribution of temperature in the troposphere is controlled primarily by the heating and cooling of the earth's surface, together with the subsequent convective activity. The manner in which air temperature changes horizontally, vertically, and with time, largely governs both weather and upper winds. Since the role that heat plays in the production of weather is of vital importance, an understanding of the various ways by which heat is transferred from one place to another is necessary. The three physical processes of heat transfer are conduction, convection, and radiation.

a. Conduction. Conduction is the transmission of energy within a substance by means of internal molecular activity, without any net external movement of the substance. For example, when the end of a poker is held in a fire, the heat is transmitted from the hot to the cool end. The thermal conductivity of different substances varies widely. As a rule, metals are good conductors and gases are poor conductors. In the atmosphere, heat is transferred by conduction to and from air which comes in contact with the earth's surface. Since the atmosphere is a gas, it is a poor conductor and only the lower layers next to the surface are affected by conduction. The amount of heat transferred by conduction in the atmosphere is negligible when compared to that transferred by convection and radiation.

b. Convection. Transfer of heat by means of physical movement of the medium through which the heat is transferred is known as convection. In meteorology, convection is a term used exclusively to denote vertical air motion, and the transfer of heat by horizontal movement of air is referred to as advection. Large quantities of heat are continually transferred through the atmosphere by means of convection and advection. The advection process is primarily responsible for the day-to-day changes in the weather. The motion of the atmosphere is quite complex and does not follow a consistent, steady pattern. The layer of air in contact with the surface is warmed by conduction during daylight, which causes it to expand and become less dense. The less dense air rises and is replaced by cooler air from above, thus creating a convective cell similar to that about an open fire. On a small scale, this vertical motion is generally called turbulence and is quite irregular due to unequal heating and cooling of various

types of terrain. On a large scale, the vertical motion in conjunction with the horizontal motion carries excess heat from equatorial regions to the cooler areas at higher latitudes. This mass transfer of heat by means of large scale movement of the atmosphere is essential in the overall heat balance which produces the climates of the world.

c. Radiation. Radiation is the transfer of heat energy by wave-like motions, similar to radio or light waves, through space without the aid of a material medium. This process is practically instantaneous, since radiant energy travels at the speed of light (299,274 kilometers per second). Radiation is the process whereby heat is transferred from the sun to the earth. The primary method of describing radiation is by its wavelength. All radiation travels in a straight line. The earth and its atmosphere actually receive only a small fraction of the total energy radiated from the sun. The energy that reaches the earth's atmosphere is partially scattered or absorbed by the atmosphere and partially reflected and radiated back into space by clouds and the surface of the earth. The fraction of the incoming radiation which is reflected back into space is called the albedo. The albedo for the earth-atmosphere system under average conditions of cloudiness is about 40 percent. All objects receive and emit radiation in varying amounts. The amount of heat energy emitted depends primarily on the temperature of the radiating body. The higher the temperature of any substance, the more radiation it sends out. The sun, having an estimated temperature of 6,000° Kelvin (para 11a), emits most of its energy in the form of a short-wave radiation (the higher the temperature of a substance, the shorter its wavelength of maximum energy emission). Approximately half of the sun's radiation is within the visible range of wavelengths; that is, it can be seen by the human eye. Visible light lies between the ultraviolet (shorter wavelengths) and the infrared (longer wavelengths) portions of the energy spectrum. The solar energy absorbed by the earth is reradiated from the earth in the form of long infrared waves, since the earth's average temperature is in the vicinity of 288° Kelvin. The earth's atmosphere is virtually transparent to the short wave solar radiation but readily absorbs most of the outgoing long wave terrestrial radiation. Thus, the atmosphere is similar to a greenhouse in that it allows a large amount of solar energy to pass through to the earth and holds the heat in by absorbing the outgoing terrestrial radiation. Water vapor in the

air is primarily responsible for the absorption of the long wave terrestrial radiation. The atmosphere is heated by the processes of conduction and convection and by its ability to absorb outgoing terrestrial radiation.

10. Atmospheric Pressure

Since the atmosphere is a mixture of gases, it is quite natural to think of air as being very light in weight; however, the total weight of the entire atmosphere is tremendous. If the entire weight of the atmosphere were replaced by an equal weight of water, the water would cover the entire surface of the globe to a depth of 10 meters. The weight of the air pressing down on itself, so to speak, produces atmospheric pressure. Atmospheric pressure is more specifically defined as the weight of a column of air of unit cross section which extends upward from the level of measurement to the top of the atmosphere. It is apparent from this definition that atmospheric pressure always decreases with an increase in altitude (fig 2). Thus, surface pressure normally decreases as the altitude of the measuring station increases, since the length of the air column above the station becomes less. The rate of change of pressure with altitude is directly proportional to air density. This relationship is expressed mathematically by the hydrostatic equation. Pressure also varies in the horizontal. Pressure values are continuously changing (both in space and with time) primarily because of changes in air density brought about by the variations in temperature and moisture content of the air. Atmospheric pressure is measured by means of either a mercurial or an aneroid barometer. Although less accurate than the mercurial barometer, the aneroid barometer is normally used in mobile weather stations because it is portable and durable. Pressure may be measured in terms of pounds per square inch (psi), millimeters (mm) of mercury, or millibars (mb.). The millibar unit of pressure is commonly used by the military and most countries of the world. Standard sea level pressure is assumed to be 1013.25 mb. or 760 mm of mercury. A useful conversion factor to remember is that 1 mb. is equal to 0.75 mm of mercury or 0.029 inch of mercury.

11. Temperature

Air temperature is a measure of the internal energy which the air possesses. In the atmosphere, this energy causes the air to expand and become less dense. Thus, when a parcel of air is heated, it becomes lighter than the air surrounding it and

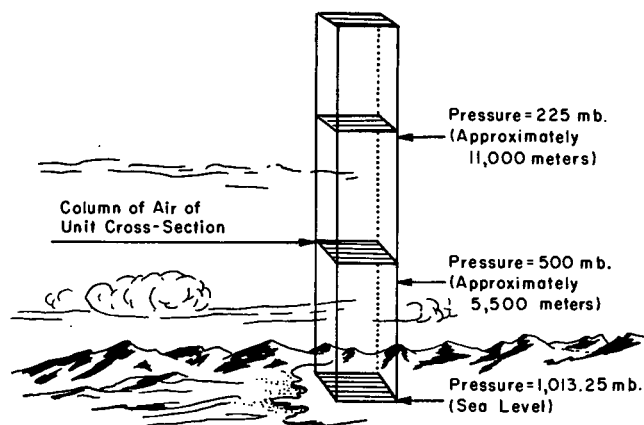

Figure 2. The decrease of atmospheric pressure with an increase in altitude.

rises. Air next to the ground tends to assume the temperature of the surface with which it is in contact. The temperature of the surface is mainly determined by the type of terrain and the amount of solar radiation available for heating purposes. The air temperature at any particular location also depends on the previous trajectory of the air. Generally speaking, surface air from high latitudes is cold and that from low latitudes is warm. Since the atmosphere receives most of its heat from terrestrial radiation, temperature normally decreases with height through the troposphere. This change of temperature with respect to height is called the lapse rate. The standard lapse rate within the troposphere is approximately 6.5° Celsius per kilometer. Under certain conditions, a layer of the atmosphere may have a temperature increase with height. This condition is known as an inversion and may occur at any height in the atmosphere. An inversion just above the ground is quite common during the early morning hours after a clear calm night. This is because the earth's surface has cooled during the night due to its loss of heat through terrestrial radiation with no compensating heat gain from the sun. The base of a well-developed inversion acts as a lid or deterrent to vertical air motion. The tropopause is an outstanding example of this phenomenon. Distinct layers of dust, fog, and smoke as well as low stratus type clouds are generally associated with inversions. Sometimes the temperature within a layer of air remains constant with height. The lapse rate in this case could be zero, and the layer is said to be isothermal.

a. Three scales are in general use for expressing air temperature—the Fahrenheit scale, the

Celsius scale, and the Kelvin scale. These scales may be distinguished by the values on each scale which are assigned to the melting point of pure ice and the boiling point of water at standard sea level pressure. On the Fahrenheit scale, 32° is the melting point and 212° is the boiling point. The Celsius scale has 0° as the melting point and 100° as the boiling point. The third scale was designed for use in scientific equations involving temperature. To express temperatures in degrees Kelvin (K), one simply needs to add algebraically the constant 273.16 to the Celsius reading. The melting point of ice on the Kelvin scale is 273.16° while the boiling point of water is 373.16° . At 0° K there is no molecular motion.

b. The temperature and pressure of the air are specifically involved in computing density. These three variables—temperature, pressure, and density—are related to each other by the equation of state (ideal gas law of physics). At constant pressure, an increase (decrease) in air temperature will cause a decrease (increase) in density. Air density is greater near the earth's surface and decreases steadily with height. The moisture content of air is quite variable, and an increase (decrease) in moisture content causes a decrease (increase) in air density. In determining air density, it would be extremely difficult and cumbersome to compute density changes caused by moisture variations in the atmosphere. Therefore, another method has been devised for determining the effect of moisture on air density. This method consists of using a fictitious temperature, called the *virtual temperature*, instead of the actual air temperature. Virtual temperature is the temperature which dry air would have in order to be of the same density and pressure as the actual moist air. In determining virtual temperature, the pressure is assumed to be constant; therefore, an increase in either the water vapor (moisture content) or the temperature will lower the density. Thus, the virtual temperature of moist air is always higher than the actual temperature. The difference between these two temperatures becomes greater as the moisture content of the air increases but rarely exceeds 3.5° C.

12. Moisture

a. Water, in one or more of its three states, is always present in the atmosphere. The oceans, which cover approximately three-fourths of the earth's surface, provide the major source of moisture for the air. Every day the sun's energy transforms millions of tons of liquid water into water vapor by the evaporation process. This

water vapor is then distributed within the atmosphere by air currents. Water vapor represents only a small percentage of the atmospheric gases—about 4 percent by volume in very moist air—and is concentrated in the lower part of the troposphere. Water vapor is, by far, the most important constituent of the atmosphere in relation to weather processes.

b. Experiment has shown that there is an upper limit to the amount of water vapor that can be contained in any given volume of air at a specified temperature. Warm air can hold more water vapor than cold air. Air is said to be saturated at a particular temperature when it contains this maximum amount of water vapor. This moisture content of air can be expressed by several different terms; however, the term understood by the majority of people is relative humidity. Relative humidity is the ratio of the amount of water vapor actually present in the air to the maximum possible amount of water vapor the air could hold at the existing pressure and temperature. Relative humidity is expressed as a percent. When the temperature of moist air increases and the moisture content remains constant, the relative humidity decreases, since the capacity of the air for holding moisture becomes greater. Relative humidity may be determined by using a psychrometer and psychrometric tables. Another term frequently used to indicate the amount of water vapor in the air is the “dewpoint temperature.” The dewpoint temperature is the temperature to which air must be cooled, at constant pressure and constant water vapor content in order for saturation to occur.

13. Clouds

a. Most weather phenomena are associated either directly or indirectly with clouds. Therefore, an understanding of the significance of certain cloud types will enable observer personnel to make pertinent and timely decisions on the effect of weather on operations. Clouds are composed of millions of water droplets and/or ice crystals suspended in the atmosphere. Clouds are formed when water vapor in the air condenses. It is evident that if no water vapor were present, clouds could not exist.

b. When the air in contact with the earth's surface is not saturated, some of the water from the surface gradually diffuses into the air as gaseous water vapor. This evaporative process continues until a state of equilibrium exists between the vapor pressure of the liquid and the partial pressure exerted by the water vapor in the air. En-

ergy is required to change water into water vapor and is primarily supplied by solar radiation. About 600 calories of heat are needed to evaporate 1 gram of water at 20° Celsius. It is estimated that approximately one-half of the sun's energy that strikes a water surface is used in the evaporation process. The rate of evaporation depends specifically on the dryness of the air above the surface, the speed of the wind, and the temperature of the moist surface (fig 3).

c. Condensation, as the term is normally applied to the atmosphere, is the process whereby gaseous water (water vapor) is changed into small droplets of liquid water. In order for condensation to occur, there must be something present in the atmosphere upon which the water vapor can condense. Literally billions of minute particles exist in the atmosphere resulting from ordinary dust, combustion products, and sea salt crystals. Clouds and fog are formed by the condensation of water vapor upon these particles, which are known as condensation nuclei. Condensation may result from either lowering the temperature, or decreasing the pressure, or from the addition of more water vapor to the air. In the atmosphere, condensation (fig 3) normally occurs when warm moist air rises and cools by expansion. Frontal activity, terrain features, and unequal heating of land and sea surfaces cause the air to rise or to be lifted. During the process of condensation, the heat which was originally absorbed by the water vapor during evaporation is released. Hence, condensation by itself tends to increase the temperature of the surrounding air.

d. Precipitation is visible moisture, either liquid or solid, which falls from a cloud to the surface. Clouds do not always produce precipitation, since the initial water droplets are extremely small and simply float in the atmosphere. Visible moisture may fall from clouds without reaching the earth's surface, because on many occasions it evaporates before reaching the surface. Precipitation occurs when the cloud particles become so large that the pull of gravity overcomes the bouyant force of the surrounding air in the cloud. The size of cloud droplets may be increased by collisions with other droplets or by the freezing of supercooled water droplets on ice crystals. Ice crystals grow quite rapidly as additional supercooled water freezes on them. The term “supercooled” is used to designate liquid moisture which exists in the atmosphere at temperatures below 0° C. The cloud particles (liquid or ice) may continue to grow by colliding with smaller particles during their fall to the surface. When the tem-

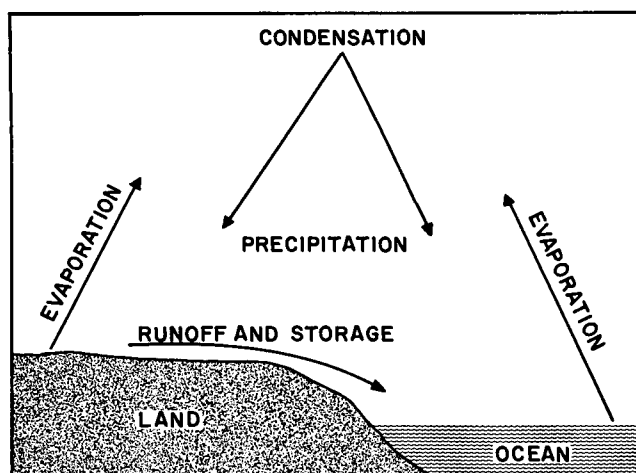

Figure 3. The water cycle.

perature of the atmosphere between the cloud and the surface is above freezing, these falling particles probably will reach the ground as liquid precipitation, although frozen precipitation may occur at relatively high surface temperatures. If the temperature is at or below 0°C ., the falling particles usually reach the ground as sleet or snow. If strong vertical currents are present within the cloud, the water droplets or ice crystals are carried to great heights. The particles involved in strong updrafts may become quite large before falling to the ground as large raindrops or hailstones.

e. Clouds are classified according to their appearance and the physical processes which produce them. All clouds, according to their shape, fall into two general categories: cumuliform (cumulus) and stratiform (stratus). Cumulus means heaped or accumulated, and cumulus clouds are always formed by rising air currents. Local showers may be the only result of cumulus clouds; however, severe thunderstorms and extremely strong vertical air currents are usually associated with cumulonimbus clouds. The tops of cumulus clouds may rise or fall at a rate approaching 300 meters per minute. Stratus, or sheetlike, clouds are formed when a layer of air is cooled below its saturation point without pronounced vertical motion. The vertical thickness of stratiform type clouds may range from several meters up to a few kilometers. Precipitation, if any, from stratiform clouds is generally continuous with only gradual changes in intensity and covers a relatively large area. Cumulus and stratus clouds may be further classified by altitude into four families: high, middle, low, and towering clouds. Cloud bases of the towering family of

clouds may be as low as the typical low clouds, but their tops may extend to, or even above, the tropopause. The mean heights of clouds shown in figure 4 are to be used as a guide only for land stations in temperate latitudes.

(1) *Below 2,000 meters.* When the bases of clouds are lower than 2,000 meters above the surface of the earth, the clouds are generally designated as cumulus or stratus, unless they are producing precipitation. A low cumulus or stratus cloud from which rain is falling is normally a cumulonimbus or nimbostratus cloud. Nimbus (nimbo) means rain cloud. Another common low cloud, with some of the characteristics of both cumulus and stratus clouds, is designated stratocumulus.

(2) *Between 2,000 and 6,000 meters.* The word "alto" generally precedes the basic cloud name to designate clouds at intermediate heights. Altocumulus and altostratus clouds are in this category.

(3) *Above 6,000 meters.* Clouds formed in the upper levels of the troposphere, that is, above 6,000 meters, are composed of ice crystals and generally have a delicate appearance. These clouds are designated as cirrocumulus and cirrostratus. At still greater altitudes, a fibrous type of cloud which appears as curly wisps and is composed of ice crystals, is designated as cirrus.

14. General Circulation

a. The temperature differences which exist between various locations on the earth produce pressure changes which initiate all air motion in our atmosphere. When the wind blows, a definite set of forces are acting on the atmosphere, causing the air to move with respect to the surface of the earth. The forces which are exerted on the atmosphere are gravity, the pressure gradient force, friction, and the apparent force (Coriolis force), which is due to the rotation of the earth. The pressure gradient force tends to move air from high to low pressure. Since pressure decreases with altitude, an upward force exists. This upward force caused by the vertical pressure gradient is counteracted by the force of gravity which is always directed toward the center of the earth. When these two forces are unbalanced, vertical air currents result. Vertical air motion may occur over large areas where the mean vertical velocities are generally less than 0.2 knot. Vertical air motion which is restricted to a small column (updraft) may have velocities greater than 20 knots. Pressure also varies in the horizontal, producing horizontal pressure gradi-

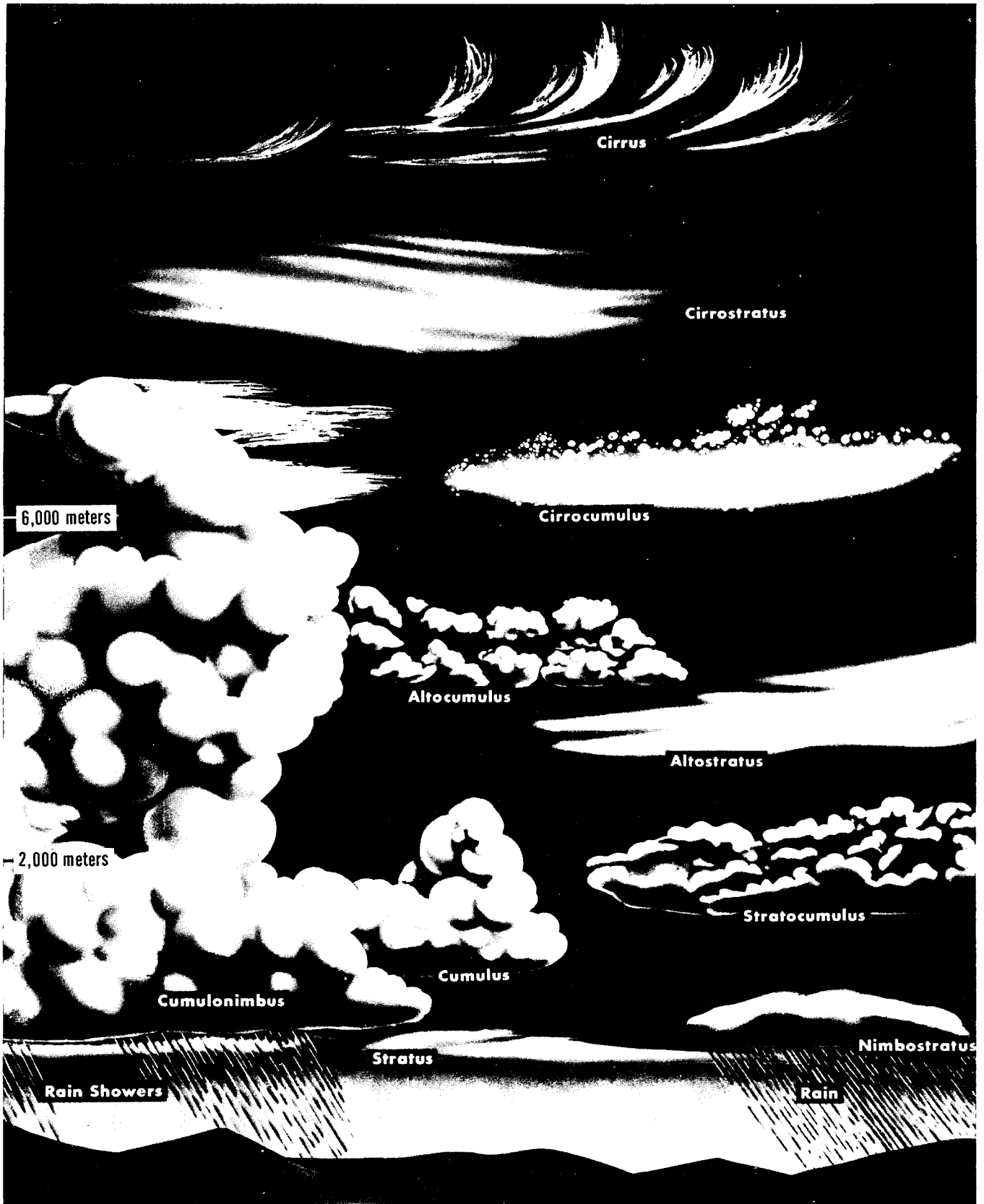

Figure 4. Cloud forms.

ents, which tend to displace the air in the direction of lower pressure. Although vertical air motion is important in cloud formation and weather, the large-scale wind systems throughout the world consist primarily of horizontal air motion. If the earth did not rotate, the air would always move directly toward lower pressures. The earth's rotation causes a deflective force, which acts at a right angle to the direction of the moving air and tends to balance the pressure gradient force. This deflective force (Coriolis force) causes moving air to deflect to its right in the Northern Hemisphere and to the left in the Southern Hemisphere. The Coriolis force is proportional to the speed of the air and to the sine of the latitude at which the air movement is occurring. Thus, for the same wind speed the Coriolis effect on air motion increases with latitude, being maximum at the poles and zero at the Equator. The horizontal wind is a result of quasi-balance between the pressure gradient force and the deflective force and will blow in a direction generally perpendicular to these forces (the pressure gradient force acts to the left looking downwind, and the Coriolis force acts to the right). The direction of wind is defined as the direction from which the wind blows. When the pressure gradient and the Coriolis forces are exactly balanced for horizontal straight line flow and friction is neglected, the resulting motion of the air is known as the geostrophic wind. The geostrophic wind blows in a straight line parallel to lines of constant pressure (isobars), with the spacing between the isobars inversely proportional to wind speed. Friction caused by air movement over the surface of the earth is effective in decreasing the wind velocity in approximately the lower 600 meters (the friction layer) of the troposphere. Above the friction layer the actual wind (averaged over large areas) is very close to geostrophic. Within the friction layer, the decrease in wind speed reduces the Coriolis force so that the pressure gradient force becomes dominant and the wind will blow across isobars toward low pressure.

b. Around the earth near the equator lies a belt of hot air laden with moisture from the ocean surfaces. This equatorial air, being lighter (due to the high temperature and high water vapor content) than the surrounding air, expands and rises. The equatorial zone is known as the doldrums, since the predominant motion of air near the surface is vertical and horizontal winds are weak and variable. The following relatively simple average atmospheric circulation pattern,

caused by the sun, would exist if the earth did not rotate and its surface were uniform. The rising air of the doldrums flows poleward aloft and converges in the polar regions. As the air travels away from the equator, it becomes more dense due to adiabatic cooling, loss of moisture as it ascends, and loss of heat by radiation into space. The cold dry air sinks to the surface at higher latitudes and begins to travel toward the Equator in the lower levels along the earth's surface. If this were the only circulation pattern, low pressures would exist in the vicinity of the Equator and high pressures in polar regions.

c. Since the earth rotates from west to east, the Coriolis force causes the air to be deflected to its right in the Northern Hemisphere. Thus, the air that rises over the hot regions near the Equator turns poleward and is deflected to the right becoming a west wind near 30° north latitude (fig 5). By the time the air reaches this latitude; it has become dense, and some of it descends to the earth's surface and causes a high-pressure belt known as the subtropical high. The descending air is compressed, heated, and spread out in both northerly and southerly directions near the surface. The southward flow of air is deflected to the right and becomes the northeast trade winds, and the northward flow of air is deflected to the right and becomes the prevailing westerlies. Only part of the air which flows away from the Equator settles in the region of latitude 30° north. The remainder of the air continues to travel aloft toward the pole. This air is quite cold and dense by the time it reaches the polar region and sinks to the surface to spread out and start back toward the equator. The earth's rotation deflects this air to the right causing the polar easterlies. The air traveling north from latitude 30° north and the air traveling south from the north polar regions meet in the vicinity of latitude 60° north and form the polar front. The air from the polar region, being much denser, causes the warmer air to be lifted until it is caught in the poleward airflow aloft and carried on to the polar region. Thus, the circulation pattern has three vertical cells with three major wind belts at the surface of the earth (fig 5). With this circulation pattern, low pressure belts exist at the Equator and latitude 60° north and high-pressure belts exist at latitude 30° north and in the polar region. This general atmospheric circulation pattern is disturbed, however, by the distribution of land and sea masses over the earth and by topography. Water heats and cools much slower than land.

Therefore, in early winter the ocean is still relatively warm compared to the colder land temperatures, and during the early part of the summer the ocean is still cold compared to the warmer land temperatures. This differential heating results in organized pressure systems which create local circulation patterns which are superimposed on the general circulation system previously described for the rotating earth. High pressures form over land during winter and over oceans during summer; while the reverse is true for low pressures. One result of this unequal heating phenomenon is a large scale seasonal circulation known as the monsoon. The monsoon circulation is best illustrated in eastern Asia where a large land mass, India, extends into the Indian Ocean. The climate of India is actually controlled by the monsoon circulation. During the summer months in India the hot land causes low pressure to exist inland resulting in an on-shore wind which brings in moisture-laden air from the ocean. This moist air is mechanically lifted as it travels up the forward slopes of the Himalaya Mountains. Extreme-

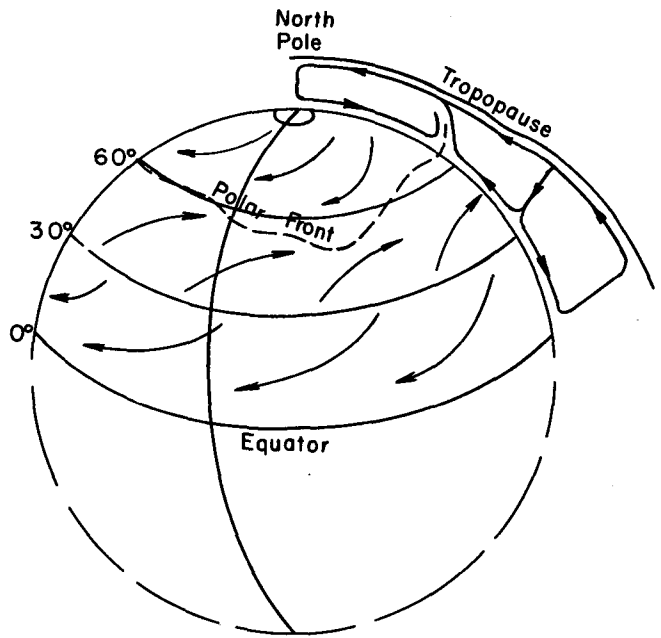

Figure 5. General circulation.



Figure 6. Orographic thunderstorm.

ly heavy rainfall occurs in this region during the monsoon season, particularly in July. On a much smaller scale this unequal heating causes a daily circulation pattern along any shoreline. During periods of fair weather, the land is warmed by the sun during the day and cooled by terrestrial radiation at night. This creates a sea breeze by day and a land breeze by night. Differential heating also causes local circulation patterns to develop in mountainous regions. The air motion is up the mountain slope during the day and down the slope toward the valley during the night. When horizontally moving air is forced to flow over mountains, the air cools as it rises and condensation may oc-

cur if sufficient moisture is present. Thus, cumulus clouds and large amounts of precipitation frequently occur on the windward side of mountain ranges (fig 6). Thermal or convective turbulence often occurs over relatively smooth land on a clear day, as the sun warms the ground and the adjacent air is heated by conduction. The heated air will rise, resulting in small vertical air currents which disturb the horizontal flow of air. Convective turbulence may also occur when cold air passes over a warm land or water surface and becomes warm by contact with the surface and by radiation.

Section III. AIR MASSES AND FRONTAL ACTIVITY

15. General

The weather over a location at a given time depends on either the character of the prevailing air mass or the interaction of two or more air masses. A group of Norwegian meteorologists initiated the idea of describing weather systems by using the air mass concept. An air mass is a vast body of air whose physical properties, primarily temperature and moisture, are nearly uniform in the horizontal plane. The transition zone, which may be quite narrow, between two adjacent air masses is called a front or a frontal zone. Large, traveling storm systems are associated with fronts and greatly affect the weather in temperate latitudes. The basis of the air mass concept is that air masses retain their identity even after they have moved a considerable distance from the region where they originally developed.

16. Source Regions

The properties of an air mass are largely determined by the type of surface over which it forms. A source region for an air mass is an extensive portion of the earth's surface whose temperature and moisture properties are fairly uniform. In order to fulfill the requirements of a good source region, an area should be either all land or all water where the same air will remain near the surface and become stagnant. Many regions of the earth do not fulfill these requirements because of their distribution of land and water surfaces. On the other hand, large snow or ice fields at high latitudes, large oceans, and large desert areas adequately meet the requirements and are called primary source regions. Secondary source regions exist, but the air masses which form over them are rather small in extent and become modified quite rapidly upon leaving the source region. The time required for a mass of air to acquire the

properties of an underlying surface varies greatly with the surface and, in some cases, may take a period of two weeks.

17. Classification of Air Masses

Air masses are classified according to the type of surface and the latitude of their source regions. The type of surface determines the basic moisture properties, while the latitude establishes the basic temperature characteristics of an air mass. The two types of surface are continental (land) and maritime (oceanic). The latitude at which the air becomes stagnant is either polar or tropical. Therefore, air masses originating in polar regions over the ocean are known as maritime polar (mP), and those originating in polar regions over land are called continental polar (cP). Similarly, air masses originating in tropical regions over the ocean are called maritime tropical (mT) and those originating over land in tropical regions are called continental tropical (cT). When an air mass leaves its source region, the state of equilibrium that existed with the underlying surface becomes disturbed, and the air mass undergoes a modification. The degree of modification depends on the contrast with the underlying surface and the speed at which the air mass is traveling. The modification process is important, since it affects the stability of the air mass, which, in turn, influences the type of weather that may be expected. Therefore, the four basic types of air masses are further identified as warm (w) or cold (k). This third letter describes the temperature of the air mass in relation to the temperature of the surface over which it is moving. For example, when a cP air mass moves over a warmer surface it is called a cPk air mass. This air mass will absorb heat from the surface and will develop instability in its lower levels because

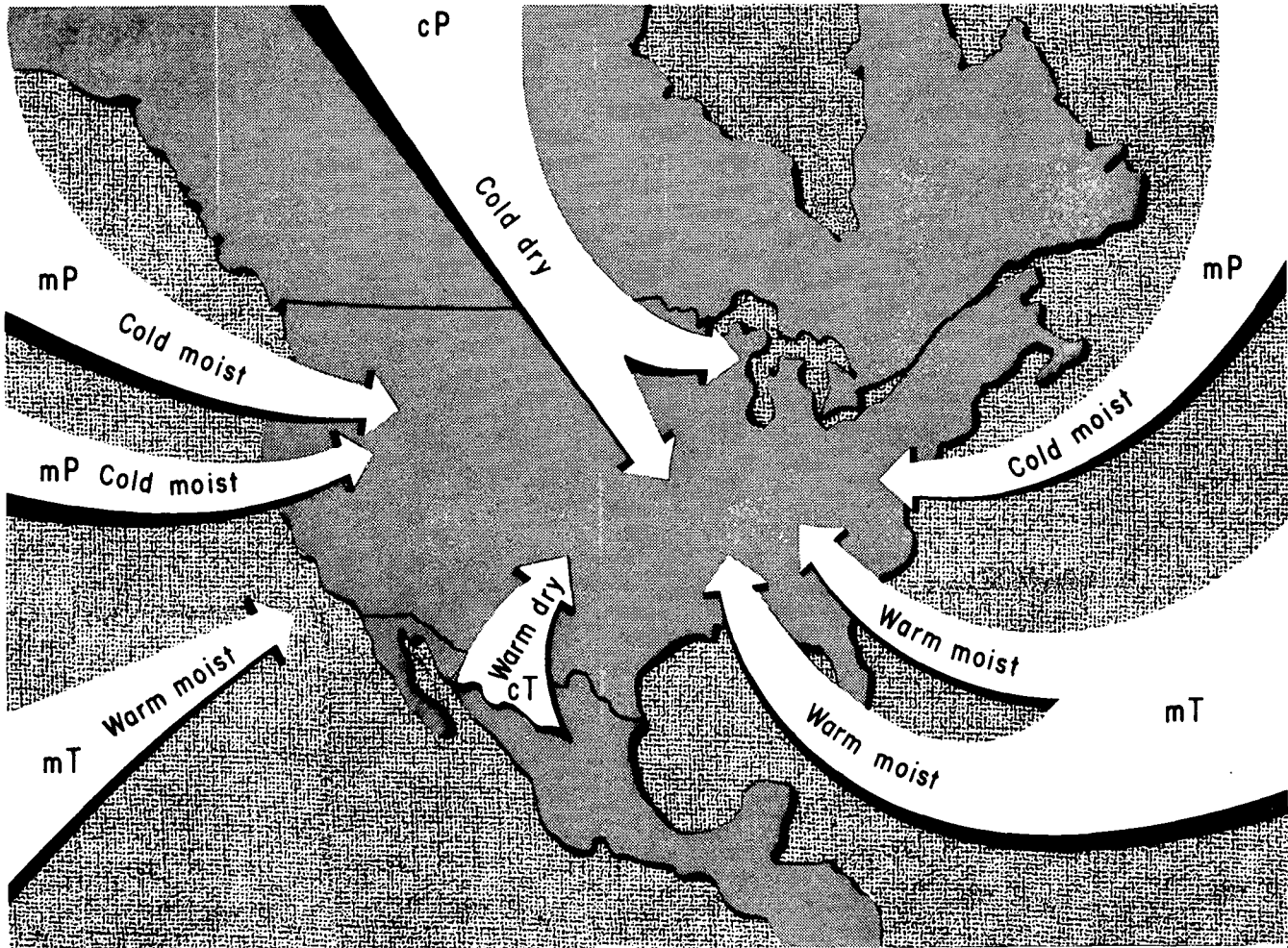

Figure 7. Trajectories of air masses into the United States.

cold air is lying on top of a warm surface. This unstable condition leads to convective activity and the formation of cumulus clouds which may provide showers or possibly thunderstorms.

18. Frontal Characteristics

a. General. At the surface, the transition zone, measured perpendicular to the front, may vary from 5 to 80 kilometers and is created when air masses of different basic properties come in contact. This zone is referred to as a frontal surface and its intersection with the earth is shown as a front on weather maps. The frontal surface is not vertical due to the differing densities of the two air masses. The colder air, being more dense, will always wedge under the warmer air mass and cause the warmer air to be lifted. All true fronts actually separate distinct air masses of different

densities. On a weather map a frontal position is characterized by a distinct change in wind direction and a kink in the isobaric pattern, with the kink always pointing toward higher pressure. The weather associated with fronts is called frontal weather and is more complex and variable than air mass weather. The type and intensity of frontal weather is largely dependent on such factors as the slope of the frontal surface (which is proportional to the amount of contrast between the two air masses), the amount of moisture, the stability of the air masses, and the speed of frontal movement. Because of the variability of these factors, frontal weather may range from a minor wind shift with no clouds to thunderstorms, hail, and severe turbulence. The passage of a front may cause rather abrupt changes in the meteorological elements observed at a given location. The

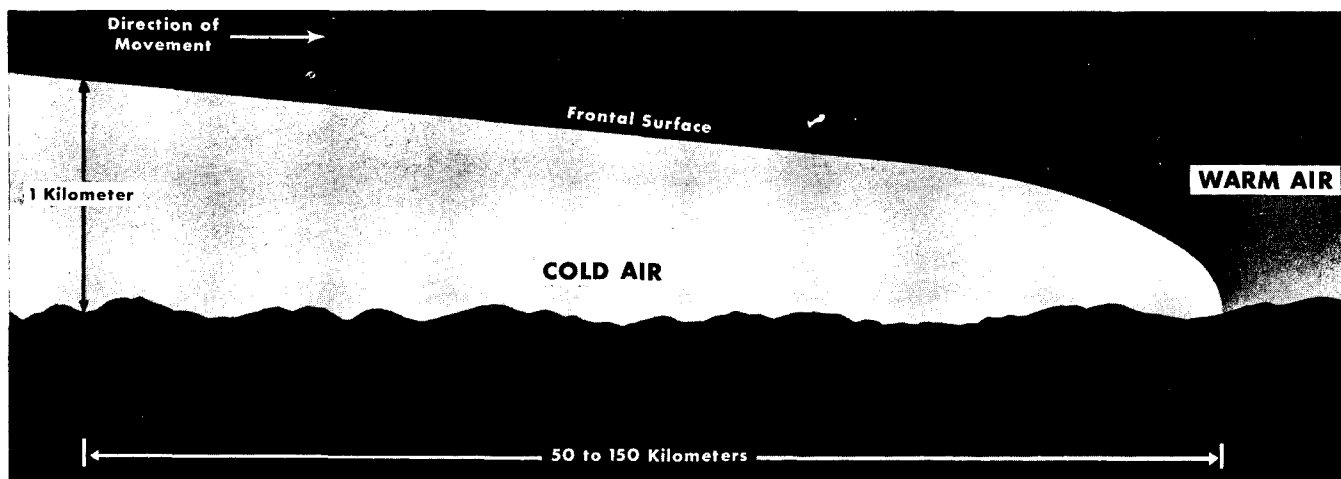

Figure 8. Cold front.

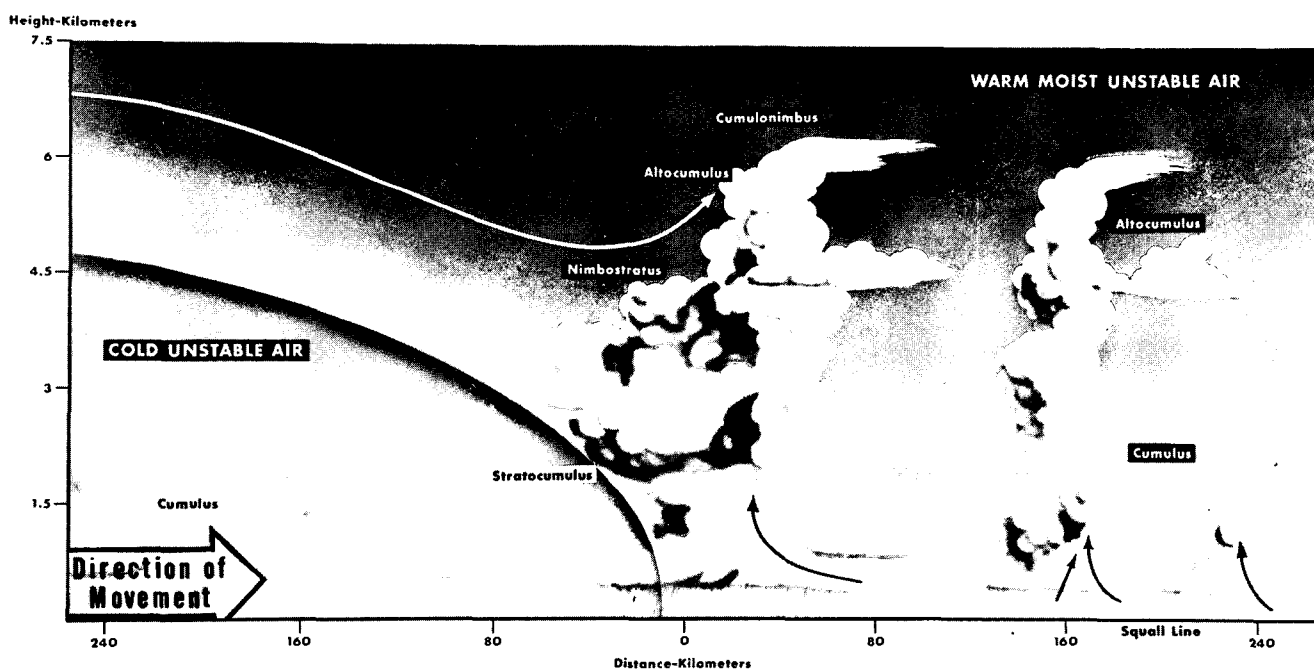

Figure 9. Fast-moving cold front.

magnitude and speed of these changes are factors in determining the frequency of observations by an army meteorological section.

b. Cold Fronts. Fronts are classified according to the relative motion of the warm and cold air masses. When cold air replaces warm air at the earth's surface, it is called a cold front (fig 8). A slow-moving cold front has a rather gentle slope,

but, as the front accelerates, the slope becomes steeper (more vertical) near the surface due to the friction of the terrain. Cold fronts normally move faster and have steeper slopes than warm fronts. The advancing wedge of cold air lifts the lighter warm air mass and produces a relatively narrow band of clouds. The type of clouds will depend on the properties of the air masses in-

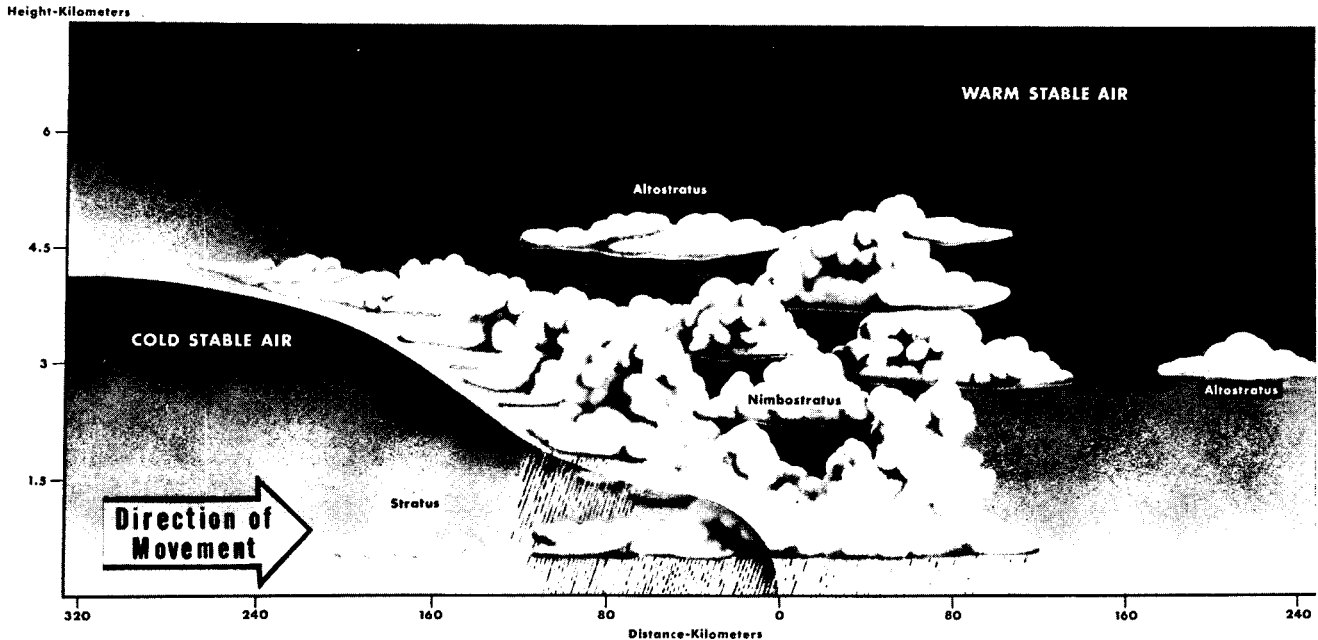

Figure 10. Slow-moving cold front.

involved and the speed of the frontal system. Fast-moving cold fronts (fig 9), when lifting moist unstable air, generate cumuliform clouds that are slightly ahead of the front. A line of thunderstorms (squall line) frequently develops parallel to and some distance ahead of rapidly moving cold fronts. The slow-moving cold fronts (fig 10) may have cloud systems which extend to the rear of the surface position of the front. The clouds will be primarily stratiform when the warm air is moist and stable. When the warm air is quite dry, little or no cloudiness will occur with the passage of a cold front. At the surface, the passage of a cold front is characterized by—

- (1) An abrupt decrease in temperature.
- (2) A marked shift of surface wind, usually greater than 90° .
- (3) A decrease in moisture content of air.
- (4) A marked decrease in pressure as the front approaches and rising pressure after the front passes.

c. Warm Fronts. When warm air replaces cold air at the surface, it is called a warm front (fig 11). The speed of the advancing warm air is greater than that of the retreating cold air; therefore, the warm air flows upward over the sloping wedge of dense cold air. The force of the rising warm air slowly pushes the cold air back. The friction effect of the earth's surface causes the slope of the warm front to be very flat. The

slope of a warm frontal surface has an average value of about 1 to 200. With the same winds, the speed of a warm front is approximately one-half that of a cold front. The clouds associated with a warm front are predominantly stratiform and extend well ahead of the surface position of the front. The weather depends largely on the stability and moisture content of the overrunning air (fig 12 and 13). Steady precipitation with low ceilings and limited visibility is normal in advance of warm fronts. At the surface, the passage of a warm front is characterized by—

- (1) A marked increase in temperature.
- (2) A slight shift of surface wind, usually less than 90° .
- (3) An increase in moisture content of air.
- (4) A decrease in pressure as the front approaches and a leveling off or slowly rising pressure after the front passes.

d. Occluded and Stationary Fronts. An occluded front is formed when a cold front overtakes a warm front and forces aloft the warm air which originally occupied the space between the two fronts (fig 14). There are two types of occlusions—the warm front occlusion and the cold front occlusion. The type which will occur depends on whether the cold air of the advancing cold front is colder or warmer than the retreating wedge of cold air in advance of the warm front. However, the essential point in both warm

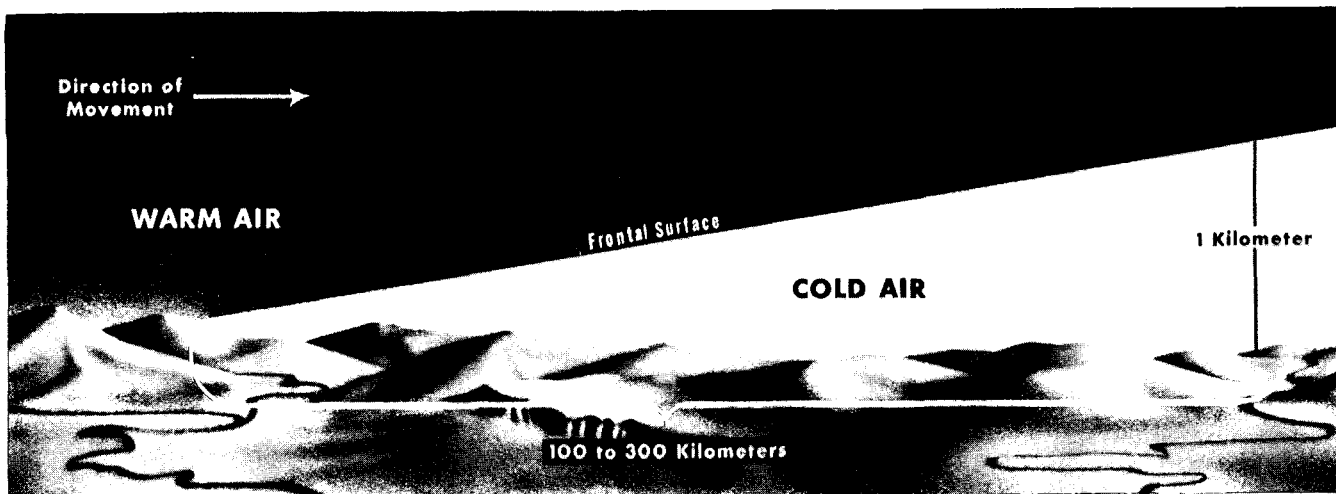

Figure 11. Warm front.

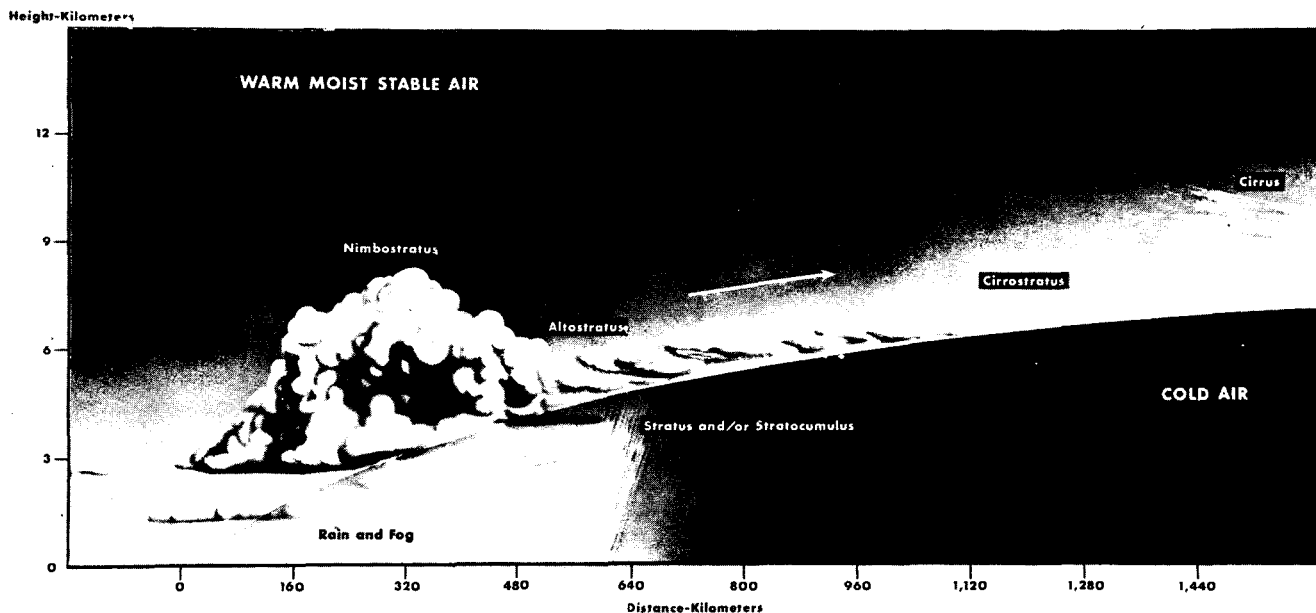

Figure 12. Stable air warm front.

and cold front occlusions is that two cold air masses meet and force the warm air aloft, causing extensive cloudiness. The weather associated with an occlusion depends on the properties of the three air masses involved. On occasions, both warm and cold air masses contain almost equal

amounts of energy and neither can move appreciably. During the period when little or no frontal movement takes place, the system is known as a stationary front. The weather associated with stationary fronts is quite similar to that accompanying a warm front.

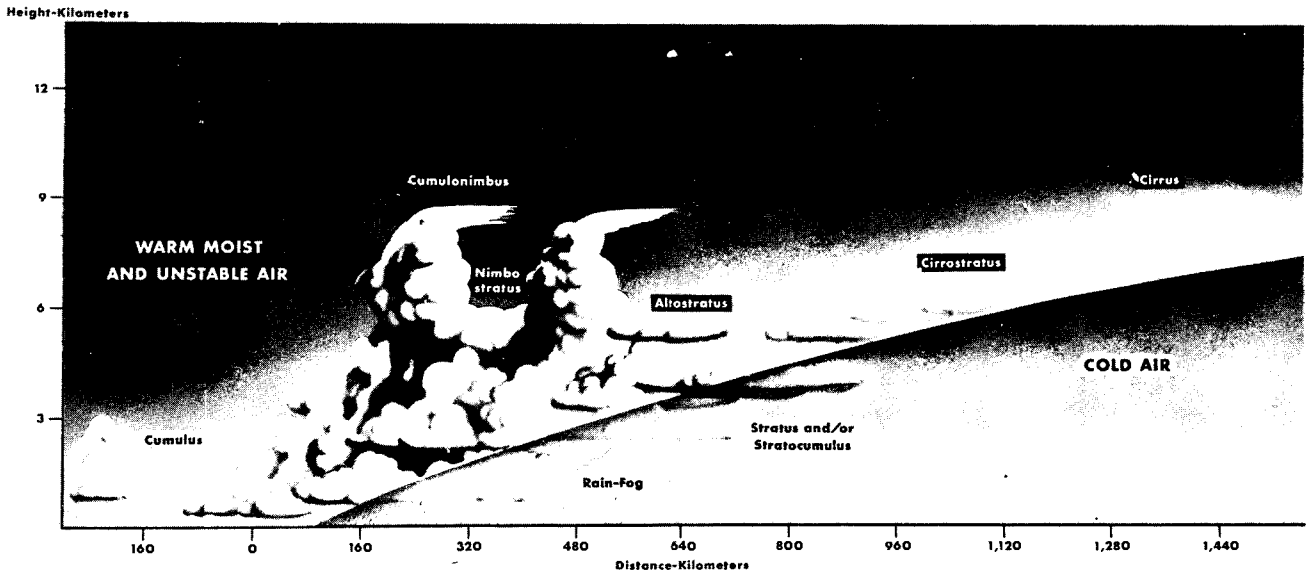

Figure 13. Unstable air warm front.

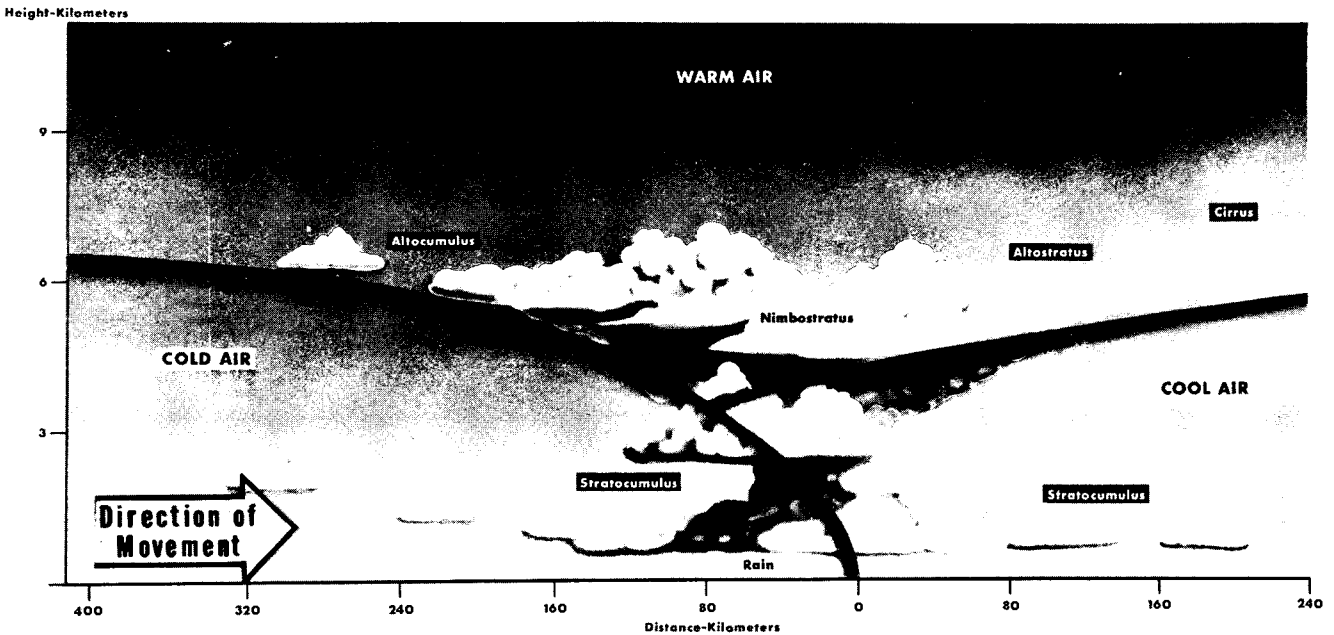

Figure 14. Cold front occlusion.

Section IV. SYNOPTIC WEATHER

19. General

Accurate weather forecasting depends on continual observations made by weather stations and military installations spread over a broad geographical region. These observations describe the condition of the atmosphere at specific times and

locations to include upper air data. The raw meteorological data are collected and transmitted by teletypewriter to weather centrals. Weather data are transmitted in an international code so that the exchange of vital weather information can be accomplished expeditiously between countries.

The observations must be furnished at regular and frequent intervals in order to provide an accurate and continuous weather picture. A large geographical network of stations is necessary since the weather which may affect one area next week is being developed today in air masses over another region of the earth's surface. A worldwide network of observation stations operates under the World Meteorological Organization (WMO).

20. Synoptic Code

Four times a day (0600, 1200, 1800, and 2400 hours Greenwich mean time (GMT)) each country transmits by teletypewriter the surface weather data gathered from a selected group of its observation stations. The synoptic code which is used to transmit these data always includes the station designator and six groups of five numbers each, which are commonly referred to as the universal groups. The significance of each figure in each group is determined by the position of the figure within the group and by the position of the group within the format. Other groups of information and/or words in plain language may be transmitted to clarify the mandatory six groups. When any weather element in the universal groups cannot be observed, an X is transmitted. The code is international and completely describes most weather phenomena. An explanation of the letters within the universal groups may be obtained from code manuals available at synoptic observing stations.

21. The Station Model

The plotting of the surface weather map from the synoptic data is accomplished for each reporting station by use of a station model. This station model has all the meteorological elements of the universal groups arranged in a uniform shorthand system about the station circle (fig 15). Plotting should always be in ink, preferably

black, so that the data will not be obscured during the analysis. The data about the station circle must be legible and should be oriented by reference to the latitude and longitude grid and not by reference to the edges of the map. Each individual develops the order in which he plots the data; however, the wind group should always be plotted first to avoid running the wind shaft through other figures or symbols. When completed, the entire station plot should cover an area the size of a dime.

22. Synoptic Chart

The surface meteorological elements, which are observed simultaneously by the network of reporting stations, are plotted to form the surface synoptic chart or weather map (fig 16). A meteorologist uses the current surface synoptic chart, together with upper air charts and adiabatic diagrams, to prepare a forecast. The first step in analyzing the plotted weather data is to place the past positions of both fronts and pressure centers on the map. Isobars, or lines of constant pressure, are then sketched at prescribed intervals. For most purposes, isobars are drawn at 3 or 4 millibar intervals; however, for a detailed analysis, this interval may be reduced to 1 millibar. Fronts, which always lie in low-pressure troughs, may be temporarily located from the sketched isobars. An examination of wind shifts, temperatures, dew points, cloud patterns, and pressure tendencies will indicate the true surface position of the fronts and often will necessitate a slight change in the isobaric pattern. Other features, such as fog and precipitation, are then placed on the synoptic chart in their respective colors so that the entire weather picture which existed at a particular hour can be seen at a glance. From the current chart, the forecaster prepares a prognostic chart, which indicates the expected weather picture for the next few hours. Generally speaking, the prognostic chart contains the same features as the current synoptic chart.

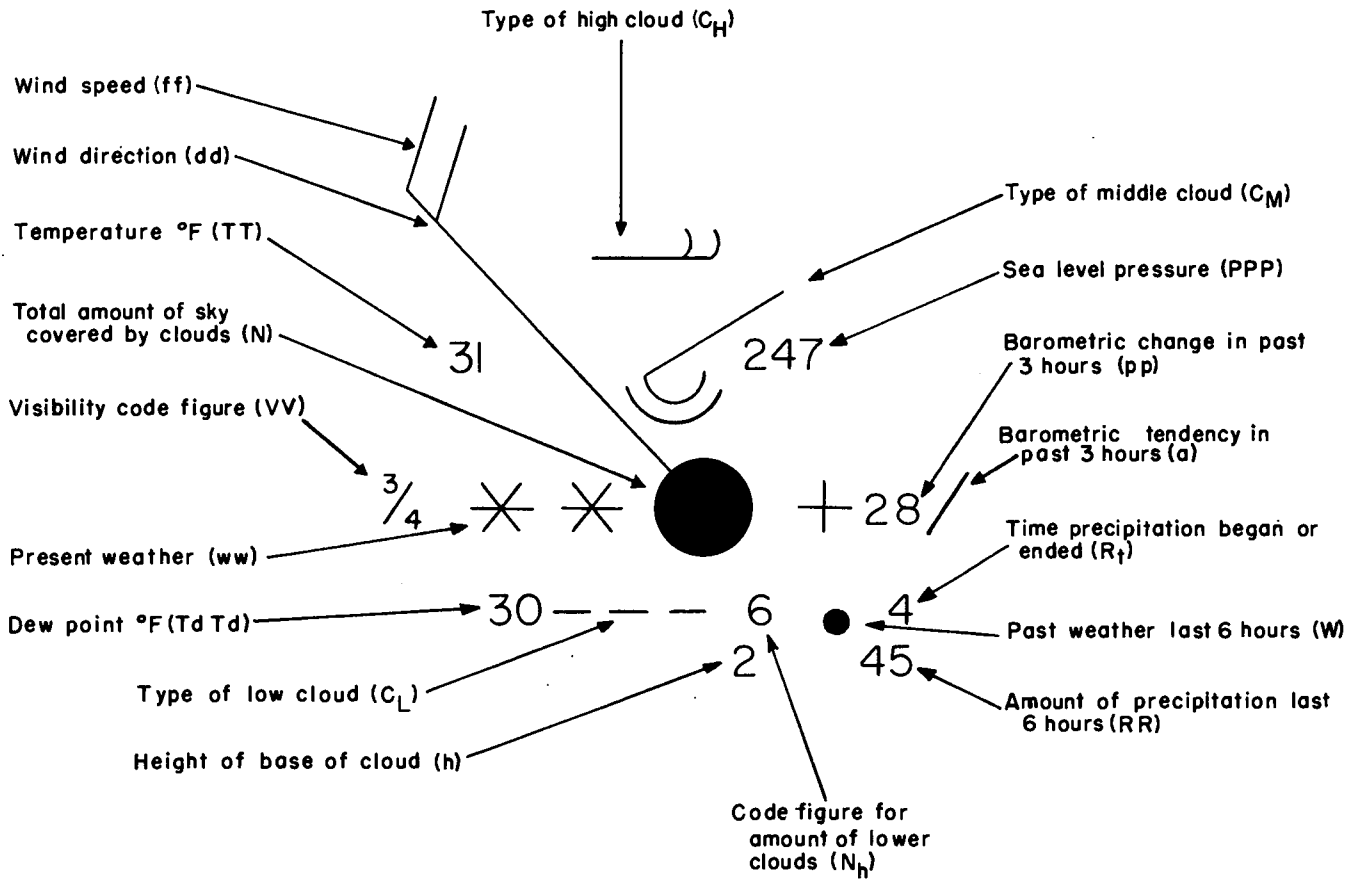

Figure 15. The station model.

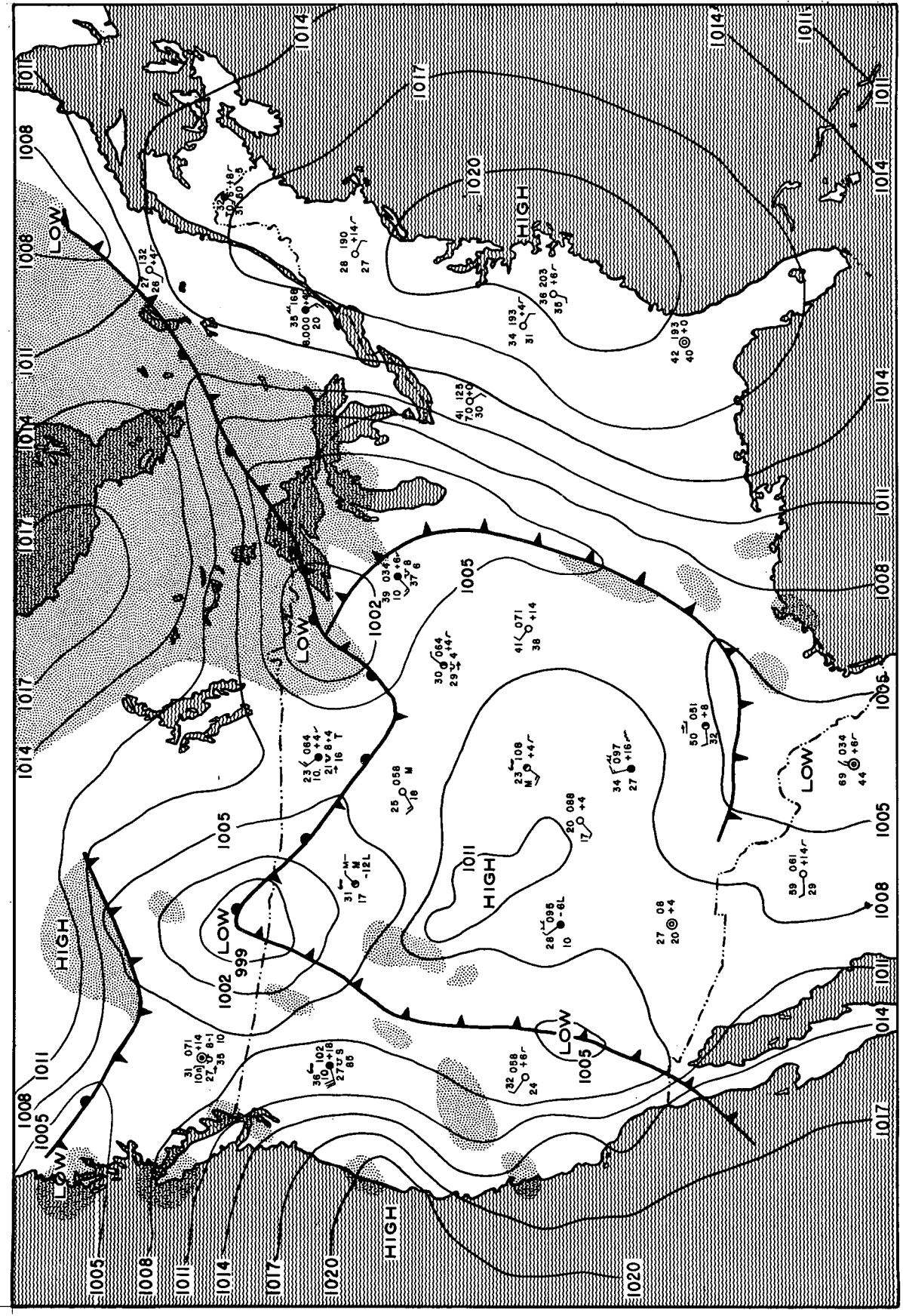

Figure 16. Surface synoptic chart.

CHAPTER 3

METEOROLOGICAL REQUIREMENTS OF THE FIELD ARMY

★23. General

There are five general meteorological requirements within the field army. They are climatological information, forecasts, surface meteorological observations, upper air meteorological observations, and weather summaries. Current met data furnished by meteorological units of the field army may include computer-type meteorological messages, ballistic meteorological messages, sound ranging messages, fallout meteorological messages, surface observations and upper air data for Air Weather service, low-level wind data for rockets, temperature-humidity (TH) index reports, wind chill factor reports, and data required by the technical services. An explanation of these reports and the services of the Air Weather Service (AWS) are described in paragraphs 212 through 221.

24. Ballistic Meteorology

a. Exterior Ballistics. Exterior ballistics is the science which deals with the factors affecting the motion of a free projectile moving through the atmosphere. A projectile moving in the atmosphere is retarded according to the same physical laws regardless of whether it was put into motion by a gun tube or launcher or was dropped from an aircraft. Generally, the forces acting on the projectile are gravity, aerodynamic drag, dynamic airfoil, and gyroscopic precession. Although these forces are few, they act and interact in an extremely complex manner. In fact, an exact mathematical solution to the motion of a projectile in space still defies mathematicians. Terrestrial gunnery does have a practical solution, however, by application of mathematical approximations. The application of mathematical approximations to the motions of projectiles is the responsibility of ordnance ballisticians. Their mathematical solutions are given to the artillery in the form of firing tables. In order to compute firing tables, ballisticians must assume certain conditions concerning the problem. These assumptions are known as standard conditions and include the projectile weight, projectile velocity, ballistic coefficient, air density, air temperature,

and wind. After a ballisticians has computed a trajectory for standard conditions, he recomputes the trajectory by allowing one of the assumed conditions to have a value different from the value of the standard. The effect of allowing an element to be different from standard is known as differential effect. Differential effects are presented in the firing tables as corrections and include corrections for range wind, cross wind, air temperature, and air density. To further illustrate how differential effects are computed, suppose that a ballisticians computes a trajectory for a 155-mm howitzer projectile for a range of 8,000 meters using standard conditions. He then recomputes the trajectory (using the same quadrant elevation), allowing only the air density to change from standard by +1.0 percent. The difference between 8,000 meters and the new computed range is the range differential effect for a 1.0 percent increase in air density. In this example, the computed range difference is -17.5 meters. The correction, or unit effect, published in the firing tables is +17.5 meters. Any correction applied will be affected by the weather and ballistic conditions encountered in approximately the same percentage as the entire range. Therefore, corrections may not always equal effects when the percentage of range lost or gain is significant.

b. Standard Atmosphere. When computing trajectories, ordnance ballisticians use the ICAO (International Civil Aviation Organization) atmosphere in accordance with international agreement among the NATO (North Atlantic Treaty Organization) nations.

Note. The ICAO atmosphere was adopted as standard up to 20 kilometers by STANAG 4044 (NATO), August 1958.

This ideal atmosphere is fully described in Report 1235, National Advisory Committee for Aeronautics, and in U.S. Extension to the ICAO Standard Atmosphere, Geophysics Research Directorate and Weather Bureau, U.S. Department of Commerce. The ICAO atmosphere is described as follows:

- (1) Dry atmosphere.

(2) No wind.

(3) Surface temperature of 15° Celsius, with a 6.5° lapse rate per 1,000 meters up to a height of 11,000 meters and a constant temperature of -56.5° Celsius between 11,000 and 25,000 meters.

(4) Surface pressure of 1013.25 millibars, decreasing with height in accordance with the equation of hydrostatic equilibrium.

(5) Surface density of 1,225 grams per cubic meter, decreasing with height according to the density equation $D = \frac{KP}{T_v}$, wherein D is the density in grams per cubic meter, K is the constant to adjust units (348.4), P is the pressure in millibars, and T_v is the virtual temperature in degrees Kelvin.

(6) The pressure, temperature, and density variations with height are illustrated graphically in figure 17. For the convenience of computing, reporting, and applying corrections, the standard atmosphere is further identified by atmospheric zones. The atmospheric zones for the various me-

teorological messages are illustrated in figure 18.

c. *Ballistic Meteorological (Met) Message.* The task of the ballistic meteorologist is to measure the parameters of the atmosphere, compare the current conditions with standard conditions, and report the variations in terms of percents of standard. The measurement of upper air parameters is made by means of a balloon-borne radiosonde. As the radiosonde ascends, it measures pressure, temperature, and relative humidity. During ascent, the radiosonde is tracked by a rawin set AN/GMD-1(). The location of the balloon at each zone limit, as projected to the earth's surface, is plotted on a plotting board. From these plots, the average wind speed and direction for each of the atmospheric zones is determined. The computation of these zone winds is a preliminary step in the determination of ballistic winds. Upper air pressure and virtual temperature are plotted on the altitude-pressure-density chart ML-574/UM. This chart is constructed so that zone temperatures and zone densities may be obtained graphically from the sounding curve

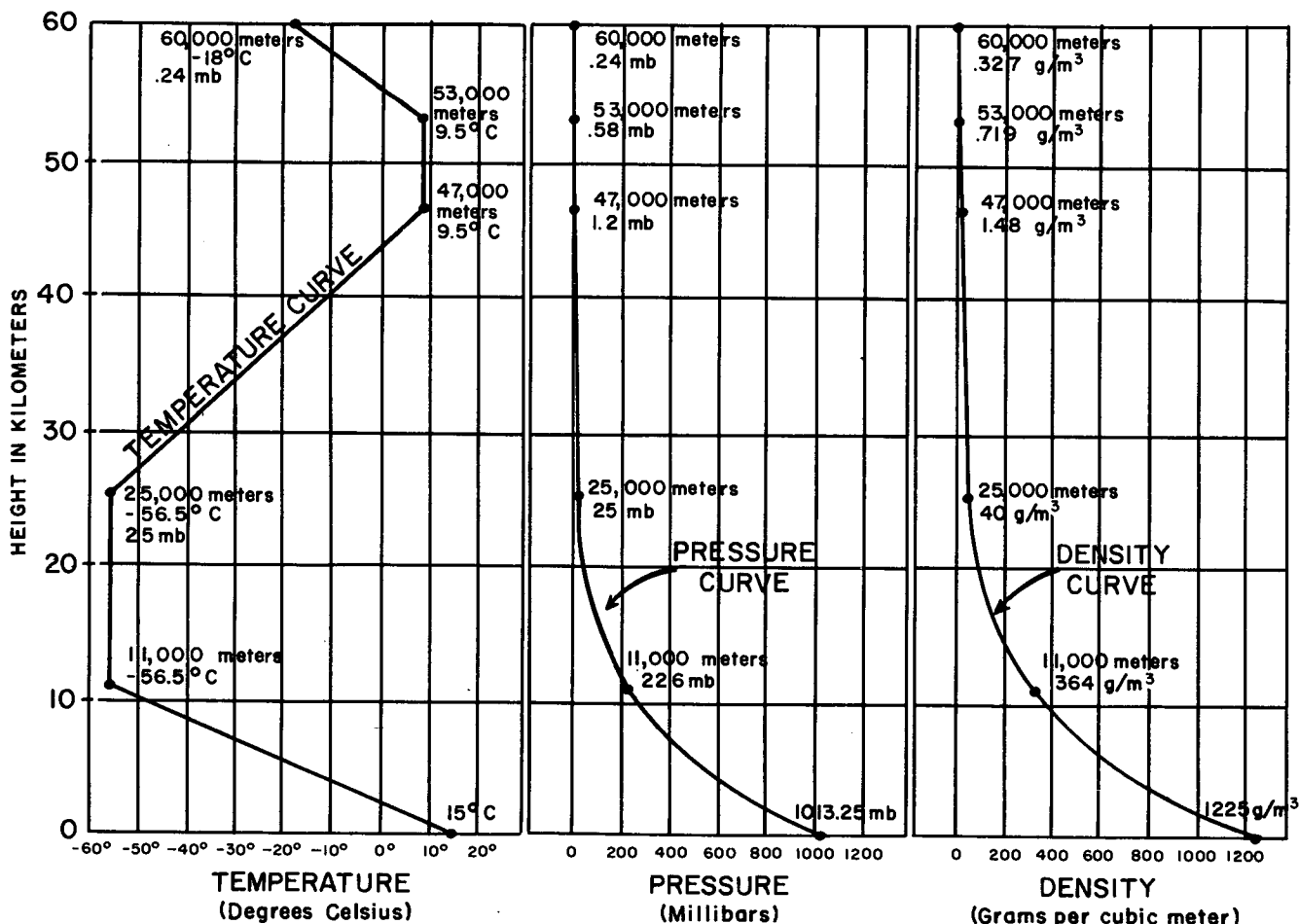

Figure 17. Standard atmosphere.

Zone structure of the NATO, computer, and fallout metro messages

Height meters	Line numbers			
	NATO	Computer	Fallout	
Surface	0	0	0	
200	1	1	1	
500	2	2		
1000	3	3		
1500	4	4		
2000	5	5		
2500	6	6	2	
3000		7		
3500	8	3		
4000	9			
4500	8			10
5000			11	
6000	9		12	4
7000	10	13		
8000		14		
9000	11	15	5	
10000	12	16		
11000	12	17	6	
12000		18		
13000	13	19	7	
14000		20		
15000	14	21	8	
16000		22		
17000	15	23	9	
18000		24		
19000		25	10	
20000		26		
* * *			* * *	
30000			15	

Figure 18. Structure of atmospheric zones.

through the use of a small plastic scale (scale ML-573). The general procedure is to determine, by plotting, the mean zone density and temperature, and then compare the results with the mean standard zone density and temperature. Since the standard atmosphere is assumed to be completely dry, any moisture in the actual atmosphere must be taken into account. This is accomplished by applying a humidity correction to the measured temperature. This corrected temperature is called the virtual temperature. The virtual temperature of moist air is the temperature which dry air at the same pressure must have in order to have the same density as the moist air. The conversion of actual temperature to virtual temperature is accomplished graphically on chart ML-574/UM or by using tables in FM 6-16, Tables for Artillery

Meteorology. The zone values of wind, density, and temperature are compared with the standard zone values, and variations from standard are determined. The variations from standard are then weighted according to specified zone weighting factors, and mean weighted quantities are established. The mean weighted quantities are the ballistic values.

(1) *Ballistic wind.* Ballistic wind is a wind of constant speed and direction which would have the same total effect on a projectile during its flight as the varying winds actually encountered.

(2) *Ballistic density.* Ballistic density is a constant density, expressed as a percent of standard atmospheric density, which would have the same total effect on a projectile during its flight as the varying densities encountered.

(3) *Ballistic temperature.* Ballistic temperature is a constant virtual temperature, expressed as a percent of standard, which would have the same total effect on a projectile during its flight as the actual temperature encountered.

d. *Weighting Factors.* Weighting factors are used to establish the proportional effect of the meteorological conditions in each zone upon the total effect exerted by the atmosphere through which a projectile passes. These weighting factors are computed by the ballisticians and are based on empirical data. To reduce the number of weighting factors two general categories of trajectories have been established—surface to surface and surface to air. A meteorological section may be required to produce both types of ballistic met messages. In either case, the message would be based on the same sounding and the same zone values, but the ballistic quantities (except for surface and line 1 of the message) would not be the same because the difference in the type of trajectory necessitates a different set of weighting factors. Appropriate weighting factors are published in FM 6-16.

e. *Ballistic Quantities.* Ballistic quantities are reported to artillery units in the met message. This message consists of a heading and a body. The heading identifies the location of the met station, altitude of the met station (MDP) (Meteorological Datum Plane), valid time period, and the station pressure (reported as a percent of standard). The body of the met message reports the ballistic quantities for each standard altitude (top of zone), including the surface. Each line of the met message reports ballistic data for that portion of the atmosphere extending from the surface to the top of the standard zone which corresponds to this line number. For example, line 5

of ballistic message contains ballistic values which represent the atmospheric layer from the surface to the top of standard zone 5. These values would be applicable for all trajectories having a maximum ordinate between 1,500 and 2,000 meters. The zone values for zones 1, 2, 3, 4, and 5 are weighted and summed to arrive at the ballistic values for line 5. Coding of the met message is further described in chapter 8, which also contains a sample message.

f. Application of Met Corrections. The importance of met corrections is sometimes minimized by artillerymen who prefer to "shoot in" these corrections by registrations. Registration is the most accurate method of accounting for nonstandard conditions. However, coupled with the Field Artillery Digital Automatic Computer (FADAC) or standard computations techniques, met data can yield first round hits. Registration is also time-consuming, expensive, and restricted only to that portion of the battlefield which can be observed. World War II statistics revealed that half of the artillery missions fired were on unobserved targets, and artillerymen in Korea encountered situations where the magnitude of the met effect amounted to 25 percent of the range, making the application of met corrections a necessity even for observed fire missions. The application of all nonstandard conditions to artillery fire are described in FM 6-40. To illustrate met effects, a specific situation is presented: The weapon is a 155-mm howitzer (M109) firing at a target range of 8,000 meters on an azimuth of 1,600 mils with charge 5 green bag (muzzle velocity 375 meters per second). The altitude of the howitzer position is 310 meters and the altitude of the target is the same. The first consideration in the met solution to this gunnery problem is the maximum ordinate of the trajectory. The answer found in Table A of Part 2-5G, FT 155-AH-2, is the line number of the meteorological message which is based on the maximum ordinate of the trajectory fired at the tabular elevation. In this case, line 3 of the met message will be used: Line 3 of the met message indicates that the ballistic conditions are—

Ballistic wind	Blowing from 2,400 mils at 19 knots
Ballistic temperature ..	103.9 percent of standard
Ballistic density	95.4 percent of standard

The next consideration is the relative height of the howitzer position with respect to the altitude of the met station (MDP). The met station is 370

meters above sea level and the howitzer position is 60 meters below the MDP. The temperature and density values must be corrected to account for this difference. The correction of ballistic values for height of the howitzer position is made by reference to the firing tables. For this specific illustration, the correction for temperature is +0.1 percent, and the correction for density is +0.6 percent. The corrected ballistic values for the howitzer are now—

Winds	2,400 mils at 19 knots
Temperature	103.9 + 0.1 = 104.0 percent
Density	95.4 percent + 0.6 = 96.0 percent

It is important to realize that the ballistic zone structure of the atmosphere must be established at the firing position. No effort is made to adjust the ballistic winds for a difference in height between battery and MDP, because there is no specific relation between the speed and direction of the wind and this height difference.

g. Computation. The total effect of any one met variable is obtained by multiplying the variation from standard by the unit corrections for this variable. Unit corrections corresponding to the charge and entry range under consideration are obtained from the firing tables (charge 5G, entry range 8000). Figure 19 is an extract from the 155-mm howitzer firing tables appropriate to the illustration. The ballistic wind must be resolved into range wind and cross wind components. This is accomplished by subtracting the firing azimuth from the ballistic wind azimuth, after the ballistic wind azimuth has been referenced to the same azimuth as the firing azimuth (grid). The result of this subtraction is known as a chart wind direction. Chart wind direction is resolved into range wind and cross wind components by referring to the firing tables. In this illustration, the chart wind direction is 800 mils (2,400-1,600). By entering Table C (Correction Components for a One Knot Wind), with the chart direction of wind, components of a 1-knot wind can be determined. This resolves into a crosswind of right .71 and a headwind of .71 for each knot of wind. For a wind of 19 knots, this resolves into a headwind of 13 knots (0.71×19 knots) and a right wind of 13 knots (0.71×19 knots). The wind components are expressed to the nearest whole knot for the remaining correction computations. Total met corrections are determined as follows:

	<i>Met Effect</i>	<i>Variation from Standard Conditions</i>	<i>Unit Correction</i>	<i>Correction</i>
Temperature	-----	Increase of 4.0% -----	-25.2 meters -----	-100.8 meters
Density	-----	Decrease of 4.0% -----	-16.6 meters -----	- 66.4 meters
Range Wind	-----	Head 13 knots -----	+12.7 -----	+165.1 meters
Cross Wind	-----	Right 13 knots -----	0.36 mils -----	R 4.7 mils

In this illustration the range wind correction is about equal to the combined temperature and density corrections and the resulting range correction is -2 meters. The cross wind correction is equivalent to about 40 meters on the ground. For detailed procedures see FM 6-40.

h. Computer Met Message. When digital computers are used to solve the gunnery problem, a special meteorological message is required. The computer message differs from the ballistic (NATO) message in that the zoning structure is different, the zone values are not weighted, and the weather elements are reported as true values

instead of a percent standard. Fire direction center (FDC) personnel input the met data into the computer, either by a keyboard or punched tape. The computer solves the meteorological portion of the gunnery problem as it computes the ballistic trajectory.

25. Meteorology for Sound Ranging

a. Sound ranging is a process employed to locate a sound source, such as the firing of a weapon or the burst of a projectile, by computation based on the speed and direction of sound waves from the source. Sound ranging is accom-

CHARGE 5G		GROUND DATA									PROJECTILE, HE, M107 FUZE, PD, M51A5 PART 2 TABLE F	
1	2	3	4	5	6	7	8	9	Azimuth Corrections			
Range	Elevation	Change in Elevation for 100 meters	Fuze Setting for	Change in Range for 1 mil Change in Elevation	Fork	Time of Flight	Drift (correct to the left)	Cross Wind of 1 knot	Dft	CW		
R	EL	C	FS	m/mil	F	TF	Dft	CW	m	mil		
7000	364.9	7.4	25.0	1.8	8	24.2	6.8	0.22				
7100	370.4	7.5	25.4	1.3	8	24.6	6.9	0.22				
7200	380.0	7.7	25.9	1.3	8	25.1	7.1	0.23				
7300	389.8	7.8	26.4	1.3	8	25.6	7.3	0.23				
7400	396.7	8.0	26.9	1.3	8	26.0	7.5	0.23				
7500	402.7	8.1	27.3	1.6	8	26.5	7.7	0.24				
7600	411.9	8.3	27.7	1.6	8	27.0	7.9	0.24				
7700	422.3	8.5	28.4	1.6	8	27.5	8.1	0.25				
7800	429.9	8.7	28.9	1.6	8	28.0	8.4	0.25				
7900	437.6	8.9	29.4	1.6	8	28.5	8.6	0.25				
8000	446.6	9.1	29.9	1.1	7	29.0	8.9	0.26				
8100	457.8	9.3	30.5	1.1	7	29.6	9.1	0.26				
8200	465.3	9.5	31.1	1.0	7	30.1	9.4	0.27				
8300	471.0	9.6	31.6	1.0	7	30.7	9.7	0.27				
8400	482.0	10.2	32.2	1.9	8	31.3	9.9	0.28				
8500	492.3	10.5	32.8	1.9	8	31.9	10.3	0.28				
8600	508.1	10.9	33.4	1.9	8	32.5	10.6	0.29				
8700	517.2	11.3	34.1	1.0	7	33.1	10.9	0.29				
8800	527.7	11.8	34.7	1.1	7	33.7	11.3	0.30				
8900	540.8	12.4	35.4	1.8	8	34.4	11.7	0.30				
9000	557.5	13.0	36.2	8	12	35.1	12.1	0.31				
9100	568.9	13.8	36.9	1.3	8	35.8	12.6	0.32				
9200	581.1	14.7	37.7	1.7	9	36.6	13.1	0.33				
9300	593.3	16.9	38.5	1.8	9	37.4	13.6	0.34				
9400	612.8	17.3	39.4	1.6	8	38.3	14.2	0.34				
9500	631.0	19.3	44.4	2.0	10	39.2	14.9	0.35				
9600	651.5	23.3	44.5	2.0	10	40.3	15.7	0.36				
9700	675.6	27.4	43.8	2.5	11	41.5	16.7	0.37				
9800	704.4	42.6	43.3	4.6	20	43.1	18.1	0.49				
9900	760.7	47.1	47.1	6	20	45.7	20.8	0.52				
9900	819.7	49.7	49.7	3	16	48.3	23.8	0.55				
9800	866.9	36.2	56.0	3	16	56.6	21.1	0.39				
9700	897.2	28.2	53.3	3	16	51.8	26.1	0.61				
9600	917.2	20.4	54.2	2	12	52.7	30.8	0.69				
9500	939.0	17.7	55.0	6	20	53.5	31.3	0.65				

CHARGE 5G		CORRECTION FACTORS																
PROJECTILE, HE, M107 FUZE, PD, M51A5 PART 2 TABLE F		10	11	12	13	14	15	16	17	18	19	Projct of @ @ @ @ is std						
Range	Range Corrections For:																	
	Muzzle Velocity 1 m/s		Range Wind 1 knot		Air Temp 1%		Air Density 1%		Projct of @ @ @ @ is std									
	Decrease of	Increase of	Head Wind	Tail Wind	Decrease of	Increase of	Decrease of	Increase of	Decrease of	Increase of								
R	MV	MV	RW	RW	AT	AT	AD	AD	PW	PW	m	mil						
7000	19.8	-18.1	10.8	-9.7	22.8	-22.5	-13.1	13.2	-25	26								
7100	19.0	-18.2	11.0	-9.9	22.1	-22.8	-16.5	13.5	-25	26								
7200	19.3	-18.4	11.2	-10.1	21.4	-23.1	-12.8	13.9	-25	26								
7300	19.5	-18.6	11.4	-10.2	21.7	-23.3	-14.1	16.2	-25	26								
7400	19.7	-18.8	11.6	-10.4	22.0	-23.6	-16.5	16.6	-25	26								
7500	20.0	-19.0	11.8	-10.5	22.3	-23.9	-14.8	11.9	-65	27								
7600	20.2	-19.2	12.0	-10.7	22.6	-24.2	-12.2	13.3	-25	27								
7700	20.4	-19.4	12.2	-10.8	22.9	-24.4	-14.5	13.7	-25	27								
7800	20.7	-19.6	12.4	-11.0	23.2	-24.7	-11.9	16.1	-25	27								
7900	20.9	-19.8	12.5	-11.1	23.5	-24.9	-14.3	16.4	-25	27								
8000	21.2	-20.0	12.7	-11.3	25.7	-25.2	-16.6	16.8	-25	27								
8100	21.4	-20.2	12.9	-11.4	26.0	-25.4	-11.0	17.2	-25	27								
8200	21.7	-20.4	13.1	-11.6	29.2	-26.7	-17.4	17.6	-25	27								
8300	21.9	-20.6	13.3	-11.7	26.5	-26.9	-1.8	16.0	-25	27								
8400	22.2	-20.8	13.5	-11.9	29.7	-28.1	-16.2	18.4	-25	27								
8500	22.4	-21.0	13.7	-12.0	24.9	-28.3	-16.5	18.8	-25	27								
8600	22.7	-21.2	13.9	-12.2	27.1	-26.6	-11.9	19.2	-25	27								
8700	23.0	-21.4	14.1	-12.3	25.3	-26.8	-11.3	19.7	-25	27								
8800	23.3	-21.6	14.2	-12.5	27.5	-27.0	-13.8	20.1	-25	27								
8900	23.5	-21.8	14.4	-12.6	29.7	-27.2	-20.2	20.6	-25	27								
9000	23.8	-22.0	14.6	-12.7	27.9	-27.3	-20.6	21.0	-25	28								
9100	24.1	-22.3	14.8	-12.9	29.0	-27.5	-23.0	21.5	-25	28								
9200	24.5	-22.5	15.0	-13.0	26.2	-27.7	-21.4	21.0	-25	28								
9300	24.8	-22.7	15.2	-13.2	29.3	-27.9	-21.9	22.5	-25	28								
9400	25.2	-22.9	15.3	-13.3	26.3	-28.0	-22.3	23.0	-25	28								
9500	25.6	-23.2	15.4	-13.4	26.4	-24.2	-22.8	22.6	-25	28								
9600	25.5	-23.5	15.5	-13.5	29.4	-24.3	-22.3	26.2	-26	28								
9700	25.7	-23.7	15.7	-13.7	28.5	-24.4	-22.7	26.7	-26	28								
9800	26.0	-24.0	15.8	-13.8	28.6	-24.5	-22.2	26.2	-26	28								
9900	26.2	-24.2	15.9	-13.9	28.7	-24.6	-22.8	26.7	-26	28								
9900	26.0	-24.0	15.7	-13.7	28.8	-24.7	-22.7	26.2	-26	28								
9800	26.8	-24.8	16.1	-14.1	29.3	-24.9	-23.6	26.4	-26	28								
9700	27.5	-25.5	16.9	-14.9	27.5	-25.6	-26.4	25.2	-26	28								
9600	27.3	-25.3	16.9	-14.9	27.5	-25.6	-26.4	25.2	-26	28								
9500	26.9	-25.0	16.8	-14.8	27.0	-25.3	-22.2	25.1	-24	27								

Figure 19. Extract from firing table.

★plished by the sound ranging section of the batteries of the corps target acquisition battalion. These sections establish bases of microphones which pick up sound impulses for transmission to a central recorder. The sound section personnel evaluate the recording and plot the location of the sound source. The solution is based on the differences in times of arrival of the sound wave at adjacent microphones. The differences in time are related to the speed of sound and are resolved into a series of rays, the intersection of which is the location of the sound source. The variables in the system are the microphone locations, the wind displacement of the sound wave, and the speed of sound. Speed of sound is determined by the equation $V^2 = \frac{K P}{d}$, wherein V is the speed of sound

in meters per second, K is a constant which is the ratio of specific heat at constant pressure to the specific heat at constant volume of the gas, P is the air pressure, and d is the air density. Density, however, is a function of pressure and virtual temperature as shown by the equation in paragraph 24b(5), and the speed of sound (meters per second) becomes a direct function of the square root of the virtual temperature: $V = 20.06 \sqrt{T_v}$ ($^{\circ}\text{K}$). The meteorological data used to solve the sound ranging problem are wind speed, wind direction, and sonic temperature (virtual temperature corrected).

★*b.* Each sound ranging section has a limited capability of measuring the met data required. The section equipment includes pilot balloon (pibal) observation equipment, wind plotting board and equipment, psychrometer, and meteorological tables. With this equipment, the sound ranging platoon can develop all met data required. The methods of observation and computation are described in chapter 12. Artillery ballistic meteorological sections are capable of producing sound ranging met data from electronic soundings. The electronic procedures are described in chapter 13. The general requirement is to determine the wind speed and direction in four layers from the surface to 800 meters and to determine the virtual temperature at a height of 200 meters.

c. Layer winds are not used directly in solving the sound ranging problem. Layer winds are weighted and averaged in the same manner as ballistic winds to compute an effective wind speed and direction. DA Form 6-48 (Weather Data for Sound Ranging) is used for computing and reporting the sound ranging data. The winds measured with a pilot balloon by the sound ranging

section may be more valid than the winds measured with the rawin set by the ballistic meteorological section because the rawin set may be farther from the sound base. However, the measurements of the pilot balloon are restricted by visibility, whereas the measurements made with the rawin set are not. When required, meteorological support for sound ranging can be obtained from an electronic ballistic meteorological section.

26. Meteorology for Fallout Prediction

a. Nuclear detonations at or near the surface are capable of contaminating large areas with radioactive material which falls from the cloud formed by the detonation. The area of fallout varies in size depending upon the yield of the nuclear weapon, the height of burst, and the speed and direction of the wind. The area of fallout may further be modified by the presence of natural precipitation, such as rain, snow, and hail. The consideration of the area of fallout is essential in planning operations in the field army area, and the prediction of the area of fallout from both friendly and enemy bursts is a requirement of the appropriate fire support agency. The predictions of fallout from both friendly and enemy nuclear bursts are a staff responsibility of the chemical officer and are prepared by the personnel of the chemical, biological, and radiological center or element (CBRE in division, corps, or army tactical operations center (TOC)).

b. Meteorological data available for fallout prediction are the average vector winds in each 2,000 meter zone from the surface to a height of 30,000 meters. These data are furnished by artillery ballistic meteorological sections on a fixed 2-hour schedule. Because high-altitude winds are less variable than low-altitude winds, the wind data above 18,000 meters are reported every 6 hours. The average wind for each 2,000-meter zone is reported to the nearest 1 knot and to the nearest 10 mils.

★*c.* The measurements of the zone winds for fallout prediction are made in the same manner as for the artillery zones. The sounding is made by using a fast-rising or high-altitude balloon carrying the standard radiosonde. The location of the balloon at the time it reaches the limit of each fallout zone is plotted on a board. From the plots, the travel in each fallout zone is measured, and an average speed and direction are computed. Fallout winds are not weighted by the met section.

★*d.* Artillery meteorological sections report fall-

out data on DA Form 3676 (Fallout Met Message). Artillery meteorological sections in the army service area forward fallout met data to the Field Army Tactical Operations Center (FATOC) by the most expeditious means. Use of teletypewriter circuits is recommended. The detailed procedures for producing, encoding, and transmitting fallout data are described in part four of this manual.

27. Air Weather Service

a. The Air Weather Service (AWS) of the U.S. Air Force has the mission of providing weather forecasts, weather summaries, and climatological reports as outlined in AR 115-10 (AFR 105-3). Climatological information, including both climatic summaries and climatic studies, are made by AWS for the Army, as required. Air Weather Service prepares forecasts for the Army on both a routine and special basis. These forecasts normally cover periods up to 48 hours, but outlooks for 3 to 5 days can be prepared when requested. Forecasts are based on the information forwarded to the field army by the worldwide weather service of the AWS and on met data collected in the field army area by both AWS personnel and artillery meteorological sections.

b. The AWS support of the field army is accomplished through an Air Force staff weather officer (SWO) at division, corps, and army headquarters. Each SWO is supported by an AWS detachment which includes both observers and forecasters. Detachments are linked by communication lines, installed and maintained by communication units, which include both teletypewriter and facsimile facilities. The SWO operates under the staff supervision of the G2; and at corps and division headquarters he is also the AWS detachment commander. The SWO advises the commander and his staff on matters related to weather. He arranges, through AWS channels, for climatological studies and summaries required, coordinates the delivery of routine and special weather forecasts and weather summaries, and is the liaison officer between the AWS detachment and the Army element.

★c. The AWS elements with the field army are few in number and do not have an upper air sounding capability. Therefore, surface observation and upper air data collected by the artillery meteorological sections are of great importance to the AWS forecaster. Artillery meteorological sections are trained to encode surface observations and upper air data for transmission to the

nearest AWS detachment. Part five of this manual describes the code used to transmit data to the AWS and the weather capability and limitations of the AWS system in the field army area.

28. Special Weather Requirements

a. Artillerymen have a requirement for measurement of the low-level winds which affect the flight of a free rocket during the thrust period. The primary method of measuring these winds is by use of a wind measuring set which consists of an anemometer mounted on a 15-meter mast near the launcher. The measurements of the component winds are transmitted to a remotely located indicator. Artillery meteorological sections are capable of assisting rocket launcher crews in measuring the low-level winds by means of pilot balloon techniques. The capabilities and limitations of measuring low-level winds by pilot balloon techniques are discussed in chapter 23.

b. For some missiles and rockets, special meteorological data are required. It is the responsibility of missile units to make their requirements known to the nearest meteorological section. Meteorological data for missiles may require special considerations by the meteorological section.

c. All units within the field army may have a requirement for special reports, such as temperature-humidity or wind chill factor indexes. Units may require both forecasts and current reports. Forecasts are made by the staff weather officer. The procedure for making current reports is described in chapters 25 and 26.

d. When automatic digital computers are used to compute ballistic trajectories, weighted ballistic data are not required. In this case, the requirement is for true zone data. The computer is used to solve the trajectory through the atmosphere reported by the artillery meteorological section. The manner of reporting the artillery atmosphere for computer use is described in detail in chapter 8.

e. Employment of chemical and biological weapons in the battle area requires a micro-meteorological consideration of the area. The specific requirements may necessitate a great number of weather observations by all elements of the field army which have a capability to measure meteorological elements. Such measurements may include—

(1) Wind speed and direction to the nearest 5 knots and 10 degree increment of azimuth for different heights from 2 to 300 meters above the ground.

(2) Temperature to the nearest 5° F. at the 2-meter level.

(3) Vertical temperature gradient between 0.5 and 4 meters above ground.

(4) Height of inversion bases and tops between the ground and 300 meters above ground.

(5) Relative humidity to the nearest 10%.

(6) Precipitation type and quantity.

(7) Cloud cover from low, middle, and high clouds.

CHAPTER 4

**ORGANIZATION, MISSION, CAPABILITIES, AND LIMITATIONS
OF THE ARTILLERY METEOROLOGICAL SECTION**

29. Organization

a. The Field Artillery Target Acquisition Battalion Meteorological Section is composed of 1 warrant officer and 17 enlisted personnel as follows:

<i>Duty position</i>	<i>MOS</i>	<i>Grade</i>
Meteorology technician	201A	WO
Met section chief	93F40	E-7 (NCO)
Met section chief	93F40	E-6 (NCO)
Chief met computer	93F20	E-6
Met equipment mechanic	35D20	E-5
Radiosonde operator	93F20	E-5
Radio TT team chief	05C40	E-5 (NCO)
Senior met computer	93F20	E-5
Met computer	93F20	E-4
Met computer	93F20	E-4
Met computer	93F20	E-4
Met computer	93F20	E-4
Radio TT operator	05C20	E-4
Radio TT operator	05C20	E-4
Met plotter	93F20	E-3
Met plotter	93F20	E-3
Met plotter	93F20	E-3
Met plotter	93F20	E-3

b. Certain tables of organization and equipment (TOE) may modify this section organization to meet special requirements.

c. The standard artillery met section is equipped to operate for a 30-day period without resupply.

d. The major items of equipment in the operation of a met section, as listed in TOE 6-576G are:

- 1—Barometer, aneroid: ML-333/TM
- 2—Binocular, 7x50 military reticle
- 1—Calibrator, frequency, TS-65/FMQ-1
- 1—Clock, message center
- 2—Compass, unmounted, magnetic, mil graduations
- 1—Generator set, gasoline engine, 2.5-kw, 60-Hz, 1-phase, AC, skid-, shock-mounted, PE75
- 1—Generator set, gasoline engine, 3-kw, DC, 28-volt, skid-shock mounted
- 1—Generator set, gasoline engine, 10-kw, 60 Hz, 1-3 phase, AC, 120/240 volt, skid mounted

- 1—Machine gun, 7.62mm
- 1—Meteorological station, manual, AN/TMQ-4
- 1—Multimeter, ME-26/U
- 1—Multimeter, TS-352/U
- 1—Radio teletypewriter set, AN/GRC-142
- 1—Radiosonde baseline check set, AN/GMM-1
- 1—Rawin set, AN/GMD-1
- 1—Recording set, weather data, AN/TMQ-5
- 1—Stop watch
- 1—Support, radiosonde, MT-1335/TMQ-5
- 1—Test set, electron tube, TV-7/U
- 1—Tool kit, radar and radio repairman
- 2—Trailer, cargo, ¾ ton
- 2—Trailer, cargo, 1½ ton
- 1—Trailer, tank water, 400 gallon
- 2—Truck, cargo, ¾ ton
- 2—Truck, cargo, 2½ ton
- 1—Truck, van, shop 2½ ton

e. The component parts of these major items are described in the appropriate technical manuals. Most of the operating expendables are listed under meteorological station, manual AN/TMQ-4 and include approximately 5,400 pounds of materiel.

f. The equipment lists may be modified by tables of organization and equipment to meet specific requirements of various units.

30. Mission

The mission of the artillery met section is to fulfill the meteorological needs of the field army by providing—

- a. Ballistic messages.
- b. Artillery computer messages.
- c. Fallout meteorological messages.
- d. Sound ranging messages.
- e. Met data to the Air Weather Service with the field army.

31. Employment

a. Artillery met sections are assigned as follows:

One to each infantry, mechanized, armored, airborne, and airmobile division artillery.

Two to each corps target acquisition battalion.

One to each air defense group armed with guns.

One to each Honest John and/or Little John battalion when assigned to a missile command. Also, one to each Honest John battalion as an augmentation when the battalion is operating independently.

One to each artillery battalion of separate brigades.

b. It is not expected that either air defense gun units or missile commands will be employed in the field army area. Therefore, within a typical corps consisting of four divisions (fig 20), six artillery met sections are deployed. Each division artillery met section accompanies its own division artillery. The met sections of the target acquisition battalion are deployed where they can best support the overall meteorological requirement. Because of the requirement for fallout meteorological messages throughout the field army area, it is recommended that one met section of the

corps target acquisition battalion be employed near the corps rear boundary to produce fallout data for the rear area. It is recommended that the other target acquisition battalion section be employed in the division combat zone where it can best supplement the division artillery sections. Such a disposition of sections is shown in figure 21.

c. Division artillery met sections are located in the division artillery zone of action. Meteorological section locations are established where the sections can best sound the atmosphere through which the trajectories of the division artillery weapons will pass. The sections should be well forward and within a command post area where communication facilities are available. Prevailing winds, tactical location of artillery units, communication facilities and capabilities, administrative support, and local security are considered in selecting the position of a meteorological section.

d. One of the met sections of the target acquisition battalion is normally employed in the forward combat area. The second section may be employed either forward or in the corps rear area,

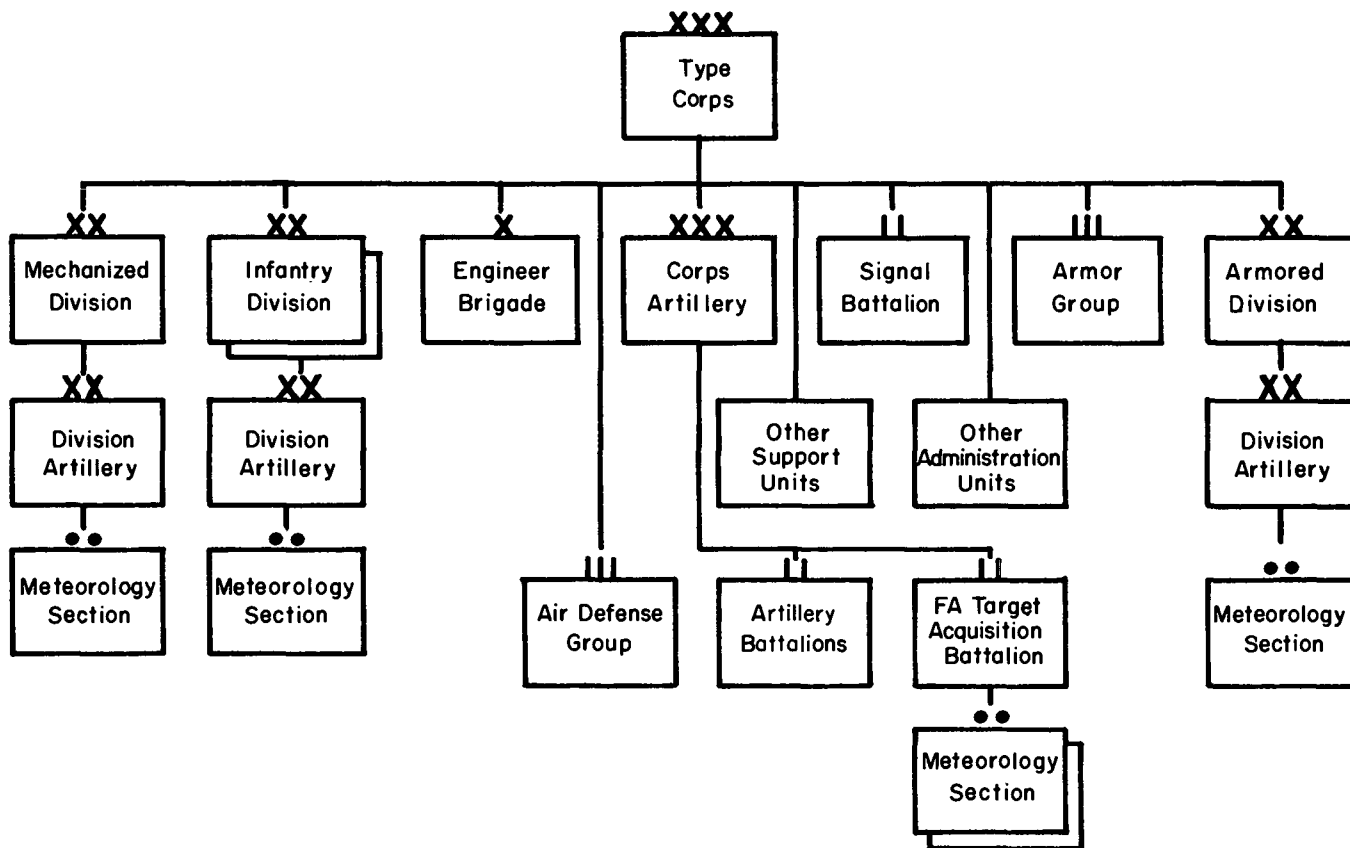

Figure 20. Type corps.

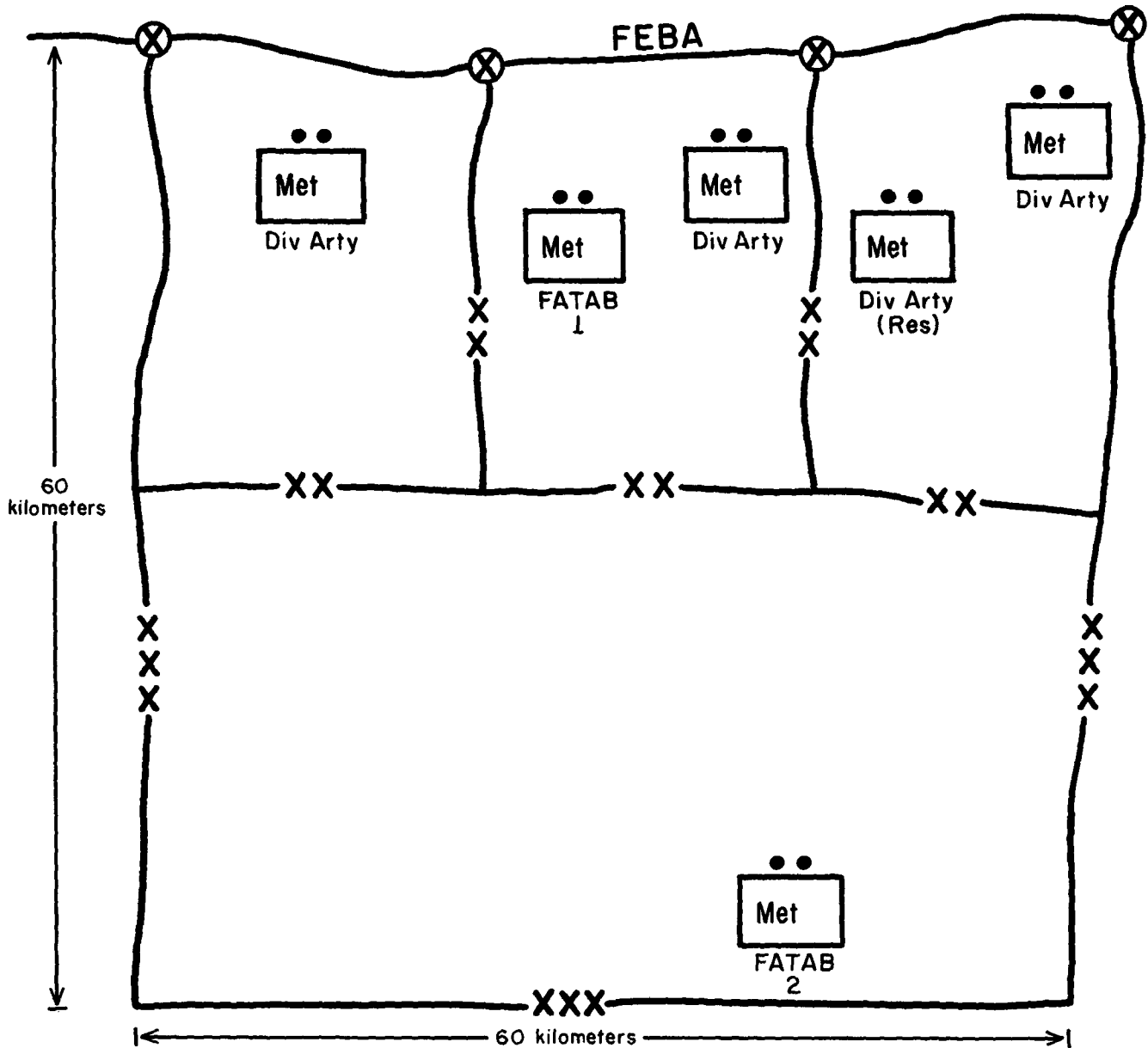

Figure 21. Disposition of met sections.

depending on the meteorological requirements. Disposition of the sections is made by the corps artillery commander, who is advised by the corps artillery met officer. The forward section should always be positioned where it can best supplement the division artillery sections. This position may be in the corps artillery command post area, the target acquisition battalion headquarters command post area, or the command post area of any subordinate unit. It is desirable that met messages be delivered in written form. This may be accomplished by utilizing radio teletypewriter nets when possible. The rear section is the net control station for the corps artillery met radio

net. When the second section is operating in the rear, it normally will have a fallout message requirement only. The rear section is positioned in any rear area command post which has communication with either the army artillery operations center or the army or corps tactical operations center.

32. Artillery Met Staff Officer

a. The operation of the artillery met system requires that the artillery commanders at division artillery, corps artillery, and army artillery be continuously informed of the met situation by the artillery met staff officer. The artillery met

staff officer of the division artillery staff is the warrant officer of the division artillery met section. The corps artillery met staff officer is a commissioned officer of the S3 section. He may be assisted by the met officer of the quality control team at corps artillery.

b. The duties of the division artillery met staff officer are to—

(1) Supervise the operation of the met sections to include the production of—

- (a) Ballistic met messages.
- (b) Fallout met messages.
- (c) Met data for artillery computers.
- (d) Met data for Air Weather Service detachments.

(2) Provide liaison on met matters with higher headquarters, adjacent division artilleries, the corps target acquisition battalion, and Air Weather Service detachments.

(3) Advise the commander and staff on all artillery met matters.

(4) Advise the headquarters battery commanding officer on the selection of positions for meteorological stations.

(5) Advise and assist the S4 in the procurement of met supplies.

(6) Advise the commander concerning the allotment of radiosonde frequencies.

(7) Advise and assist the S3 in organizing and supervising the met training program.

(8) Submit the necessary reports and keep pertinent records.

c. The duties of the corps artillery met staff officer are to—

(1) Supervise the operation of the corps artillery met sections to include the production of—

- (a) Ballistic met messages.
- (b) Fallout met messages.
- (c) Met data for artillery computers.
- (d) Met data for Air Weather Service detachments.

(2) Coordinate met matters with the division artillery met sections within the corps.

(3) Advise the corps artillery commander and staff on artillery met matters.

(4) Provide liaison on met matters with the adjacent corps and with army artillery headquarters and the staff weather officer (SWO) at corps headquarters.

(5) Advise and assist the corps artillery S4 in the logistical support of the corps met system.

(6) Advise the corps artillery communications officer on the assignment of radiosonde frequencies.

(7) Advise and assist the S3 in organizing and supervising the met training program.

(8) Advise the corps S3 on the employment and operation of met sections within the corps.

d. The duties of the corps artillery quality control team are—

★(1) Maintain quality control of the meteorological data in the corps area by checking samples of the data evaluated by the met sections within the Corps.

(2) Perform inspections of all met sections in the corps area at the direction of the corps artillery met staff officer.

(3) Provide assistance to all met sections in the corps area on problems of maintenance, training, and supply.

(4) Act as an advisor to the corps artillery met staff officer in matters concerning—

- (a) Ballistic met messages.
- (b) Artillery computer messages.
- (c) Fallout met messages.
- (d) Liaison with Air Weather Service.
- (e) Scheduling of the corps met observation schedule.

(f) Coordination of special met requirements.

33. Capabilities of Artillery Met Sections

★a. Artillery met sections have the capability of sounding the atmosphere to heights of 30,000 meters, day or night, and in all types of weather except severe surface winds. These sections are mobile and have a mobility compatible with that of a division artillery headquarters command post. The sections normally carry a 30-day supply of expendables and spare parts. Artillery met sections in a corps area communicate with each other and exchange met data on the corps artillery met net. Artillery units with the corps ordinarily will obtain met data by monitoring the corps artillery met net at specified times. They may also obtain met data over either of the two division artillery command/fire direction nets, RATT.

b. Met sections are capable of sounding the atmosphere approximately every 2 hours. A limiting factor is the period of time required for a sounding balloon to reach a required height. Where requirements for high altitude soundings exist and several types of messages are required, met sections are capable of sounding the atmosphere only every 4 hours. A met section in position is capable of producing a ballistic message for light artillery in a minimum time of 30 min-

utes after the release of the balloon. The maximum time required to produce a maximum height fallout message is about 2 hours. In the event of failure of electronic equipment, sections have an alternate but limited capability of measuring upper air winds by observing pilot balloons and of computing upper air densities and temperatures by using climatological tables in conjunction with the current surface values of each parameter.

c. All artillery met sections are trained to produce the following types of messages and data:

- (1) Ballistics messages, types 2 and 3.
- (2) Computer messages.
- (3) Fallout messages.
- (4) Sound ranging messages.
- (5) Data for transmission to Air Weather Service.
- (6) Low-level winds for rockets.

Sections are further capable of reporting a variety of special parameters such as the temperature-humidity index, wind chill factor, and surface winds.

★d. When possible, division artillery met sections should not be assigned the missions of providing fallout met data or upper air data to the Air Weather Service. Their primary mission should be limited to providing met data for use by artillery firing units and surface observations data to the Air Weather Service.

e. The second section of the target acquisition battalion located in the rear area should be assigned the missions of providing fallout and Air Weather Service met data.

34. Scheduling of Met Messages

The scheduling of met messages should be geared to the needs of the using units. Requirements for

fallout messages are scheduled by the corps artillery met staff officer. The division artillery S3 publishes a schedule of met requirements for the division artillery; this schedule is based on the schedule published by the corps artillery met staff officer. If there are two or more met sections in the same area, the corps artillery met staff officer coordinates the rotates the met requirements between the sections.

35. Requests for Met Support

a. In order to insure timely receipt of met information, the unit requesting met support should state specifically the information needed in the initial request. If a ballistic met message is required, the requesting unit should state the type of message, the number of lines required, delivery time, and method of delivery. Ordinarily, the number of lines requested should be no greater than the number required for the maximum ordinate expected to be fired during the period of validity of the met message. Also, if the met information is required for other than a ballistic met message, the date needed should be clearly and completely explained in the initial request. All requests for met support should state to whom the met data are to be forwarded (ordinarily to the S3).

b. Units requesting met support must realize that it is extremely difficult for a met section to provide ballistic met messages more frequently than every 2 hours. Met messages are provided on time schedules based on Greenwich mean time (GMT).

★c. Requests for ballistic met messages between NATO forces should follow the standard format of STANAG 4103 (refer to para 160).

CHAPTER 5

ADDITIONAL SOURCES OF METEOROLOGICAL INFORMATION

36. General

There are several additional sources of meteorological information available to artillery units. These additional sources include meteorological units from the various services of member countries of the North Atlantic Treaty Organization (NATO), the Air Weather Service (AWS) detachments of the United States Air Force, the meteorological agencies of the United States Navy, and the United States Weather Bureau. Data obtained from these sources may be ballistic, fallout, or computer messages in the standard format or raw unweighted data.

37. Allied Nations Met Message Service (NATO Messages)

a. During the past several years, considerable effort has been expended by members of NATO in the area of standardization. One result has been the adoption, by NATO members, of the International Civil Aviation Organization (ICAO) standard atmosphere (STANAG 4044). The ICAO standard atmosphere is now used by all services (Army, Navy, and Air Force) of each member country. NATO member countries are—

- Belgium
- Canada
- Denmark
- Federal Republic of Germany
- France
- Greece
- Iceland
- Italy
- Luxembourg
- Netherlands
- Norway
- Portugal
- Turkey
- United Kingdom
- United States

b. From a meteorological standpoint, this

means that atmospheric data can be freely interchanged between NATO member countries, regardless of which service obtained the data, with the assurance that the same atmospheric standards were used as a basis for obtaining and reporting such data.

38. Air Weather Service Support

Artillery met sections which lose their capability of making upper air soundings may request upper air data from the Air Weather Service. Use of raw data obtained from AWS is described in chapter 22. The Air Weather Service does not prepare a ballistic message.

39. U.S. Navy Support

U.S. Marine artillery units have the same meteorological equipment as U.S. Army artillery units and produce ballistic data the same as Army artillery met sections. When Army artillery units are operating with Marine artillery units, they will receive the standard NATO ballistic message. When operating with the U.S. Navy, as in a landing operation, Army artillery units may obtain ballistic met support from Navy shipboard met stations in the NATO format. Requests for meteorological support must be made well in advance of the time of need.

40. U.S. Weather Bureau Support

The U.S. Weather Bureau, as an agency of the Federal Government, may be called upon to assist in the fulfillment of the met requirements of the Army. Such a requirement would likely occur only in the continental United States. Requests for upper air data could quickly be met by any U.S. Weather Bureau station that normally sounds the atmosphere. U.S. Weather Bureau stations normally are not prepared to produce ballistic data.

PART TWO
BALLISTIC METEOROLOGY
CHAPTER 6
METEOROLOGICAL OBSERVATION EQUIPMENT

Section I. STATION, MANUAL AN/TMQ-4

41. General

The meteorological station, manual AN/TMQ-4 contains the various items of equipment required to measure and evaluate atmospheric conditions. Although the station manual is designed primarily for electronic soundings, it also contains the necessary equipment for the visual technique, which may be used in the event of an electronic equipment failure. The items of equipment and expendable supplies are packed in appropriate cases and carrying bags. Detailed information on the station manual is provided in TM 11-6660-218-12 and TM 11-6660-218-25P.

42. Main Components

The main components of meteorological station, manual AN/TMQ-4 and federal stock numbers are listed in succeeding paragraphs.

43. Inflation Equipment

The inflation equipment consists of the following items:

<i>Item</i>	<i>Stock Number</i>
Balloon inflation-launcher device, ML-594U	6660-999-2663
Hydrogen-helium volume meter, ML-605U	6660-999-2661
Hydrogen generator set AN/TMQ-3	3655-408-4683
Nozzle ML-373/GM	6660-238-3044
Hydrogen regulator ML-193 (or ML-528/GM)	6685-408-4766
Rod, ground	5975-224-5260
Bracket assembly, antibouyancy	6660-513-0090
Clamp, electrical	5975-248-5814
Coupling ML-49	4730-408-4628
Can, corrugated, galvanized iron, 32-gallon	7240-160-0440
Tube, rubber	4725-263-3308
Strap, ground assembly	6660-513-0109

44. Wind Plotting Equipment

The wind plotting equipment (fig 22) consists of the following items:

<i>Item</i>	<i>Stock Number</i>
Slide rule ML-14	7520-656-0660
Plotting scale ML-577/UM	6660-606-5835
Plotting board ML-122 with rule ML-126A	6660-663-4748

45. Temperature and Density Computing Equipment

The temperature and density computing equipment (fig 23) consists of the following items:

<i>Item</i>	<i>Stock Number</i>
Altitude-pressure density chart ML-574A/UM	6660-926-2285
Zone-height scale ML-573/UM	6660-606-5834

46. Surface Observation Equipment

The surface observation equipment (fig 24) consists of the following items:

<i>Item</i>	<i>Stock Number</i>
Anemometer ML-433/PM (fig 25)	6660-663-8090
Barometer ML-102-() (fig 26)	6685-223-5073
Thermometer ML-352/UM (fig 27)	6685-239-4019
Psychrometer ML-224 (fig 28)	6660-223-5084
Theodolite ML-474/GM (fig 29)	6660-498-9773
Timer FM-19 (fig 30)	6645-568-4995
Tripod MT-1309/GM	6760-408-4846

47. Wire Communication Equipment

The Wire communication equipment (fig 31) consists of the following items:

<i>Item</i>	<i>Stock Number</i>
Telephone Set TA-312/PT (replaces TA-43/PT)	5805-543-0012
Head and chest set HS-25-C	5965-162-8179
Reeling machine, cable, hand, RL-39 with spool DR-8	3895-498-8343
Cable, telephone WD-1/TT, 400 meters	6145-226-8812
Jack JK-54	5935-199-2455
Headset microphone H-144/U (not shown)	5965-682-2769

48. Technical Manuals

Detailed information on the equipment contained in station, manual AN/TMQ-4 is provided in the following manuals:

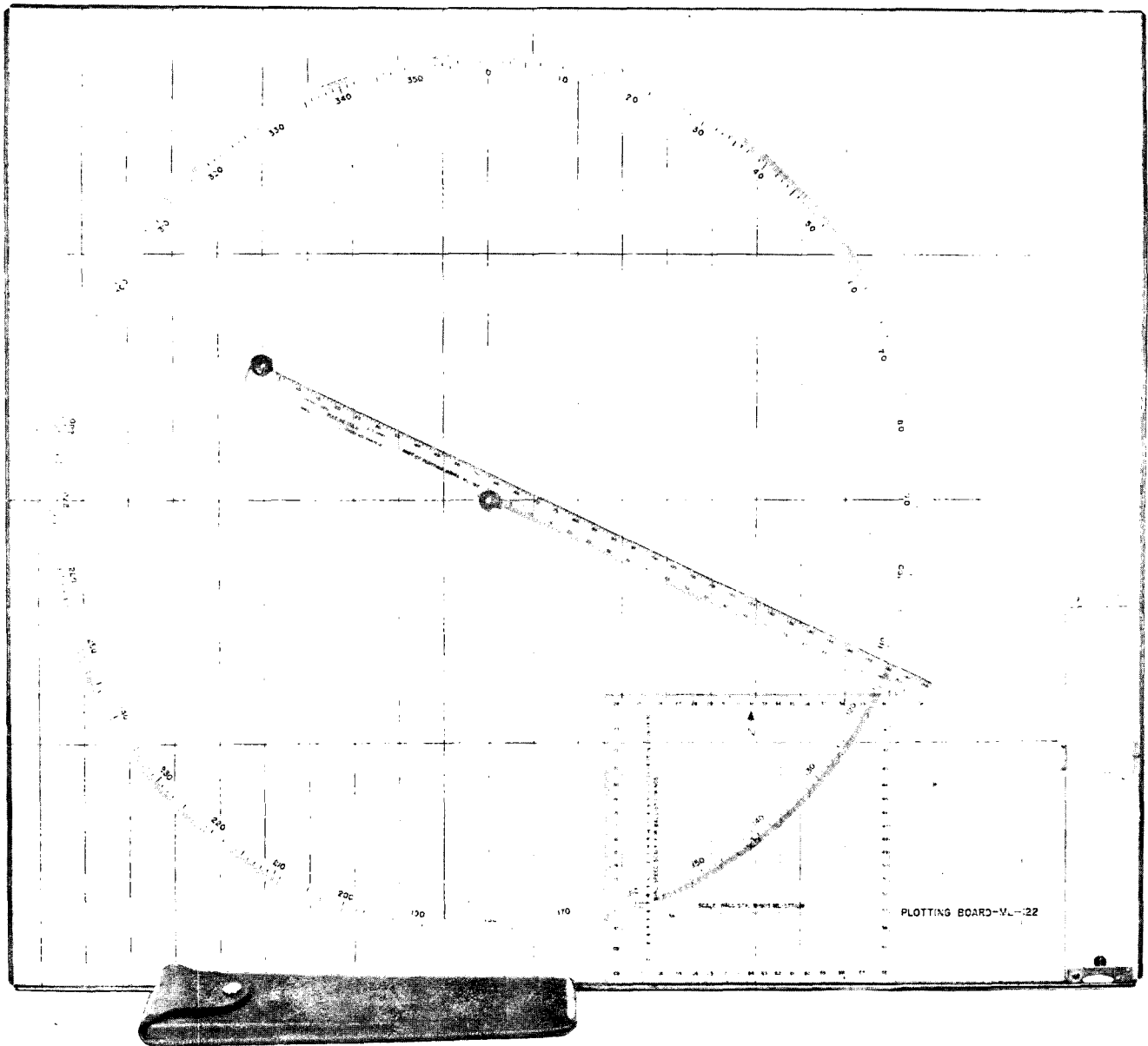

Figure 22. Wind plotting equipment.

TM 11-2413, TM 11-2421, TM 11-2432A, TM 11-2442, TM 11-6660-218-12, TM 11-6660-218-

25P, TM 11-6660-222-12, TM 11-6675-200-10, and TM 11-6675-200-20.

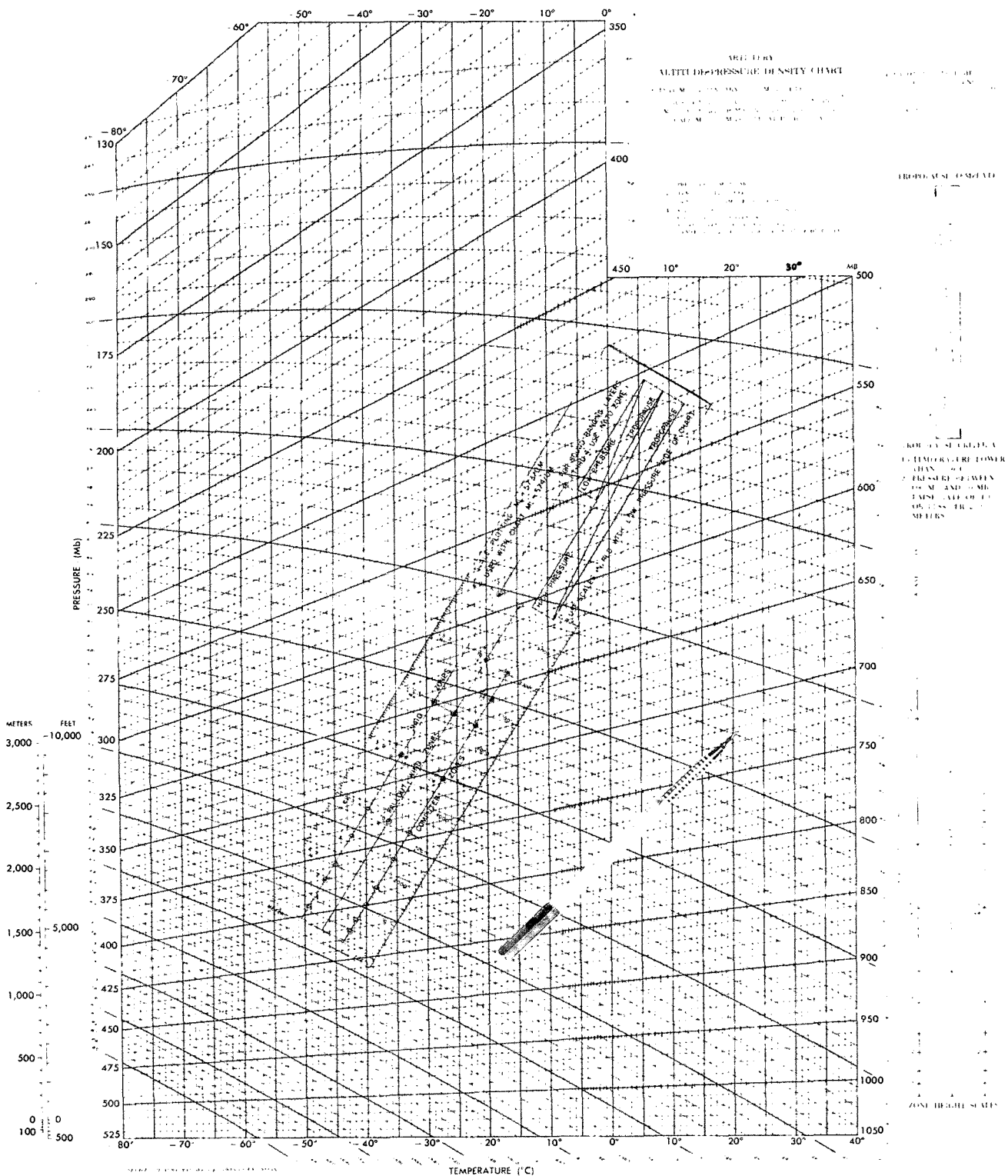
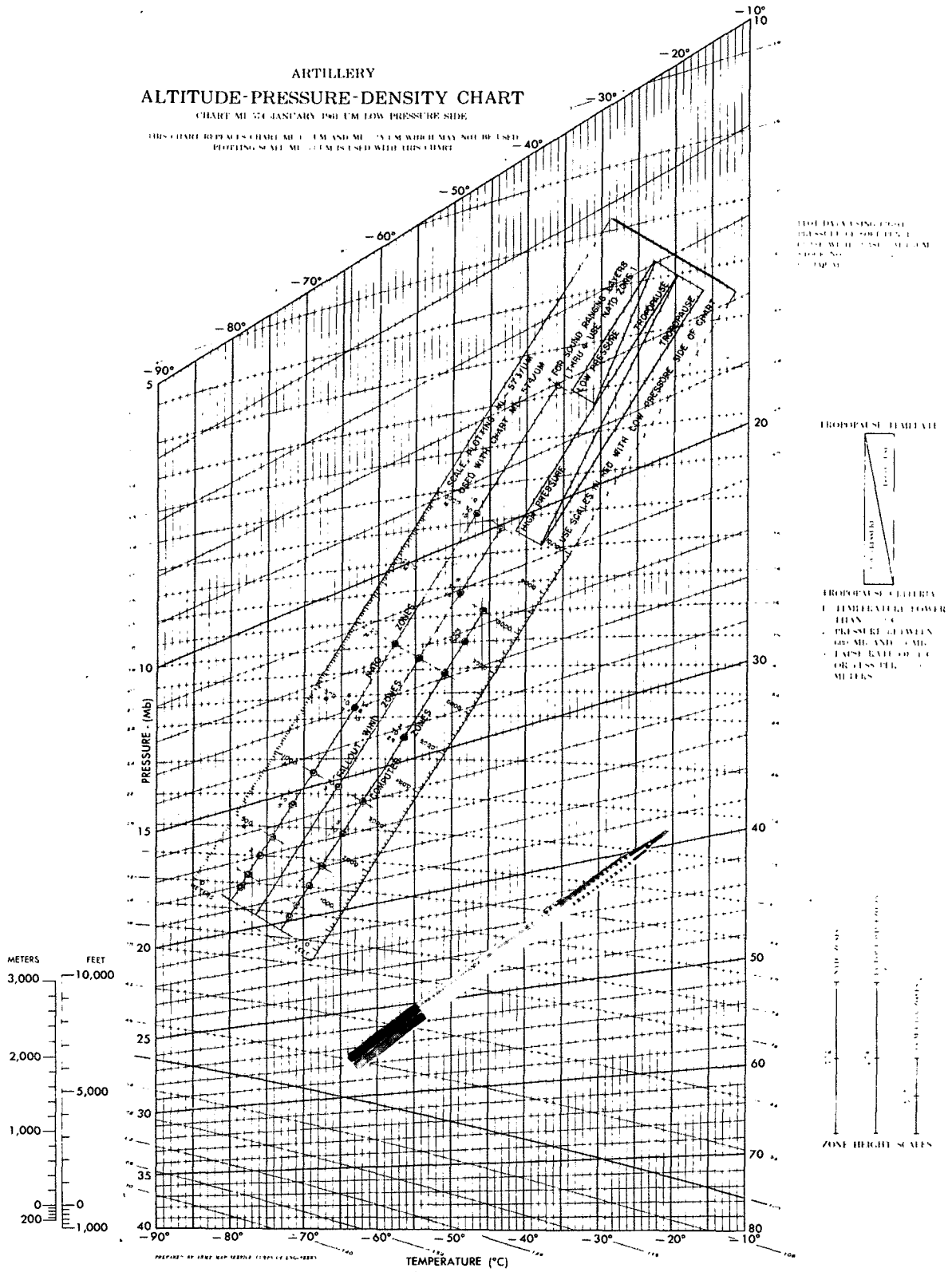

Figure 23. Temperature and density computing equipment.

**ARTILLERY
ALTITUDE-PRESSURE-DENSITY CHART**

CHART ME 57 JANUARY 1961 (M LOW PRESSURE SIDE)

THIS CHART REPLACES CHART ME 1-AM AND ME 1-2-AM WHICH MAY NOT BE USED
PLOTTER SCALE ME 1-2-AM IS USED WITH THIS CHART



THIS CHART REPLACES CHART ME 1-AM AND ME 1-2-AM WHICH MAY NOT BE USED
PLOTTER SCALE ME 1-2-AM IS USED WITH THIS CHART

TROPIC WIND ZONES
TROPIC WIND ZONES ARE USED WITH LOW PRESSURE SIDE OF CHART

ZONE HEIGHT SCALES

Figure 23—Continued.

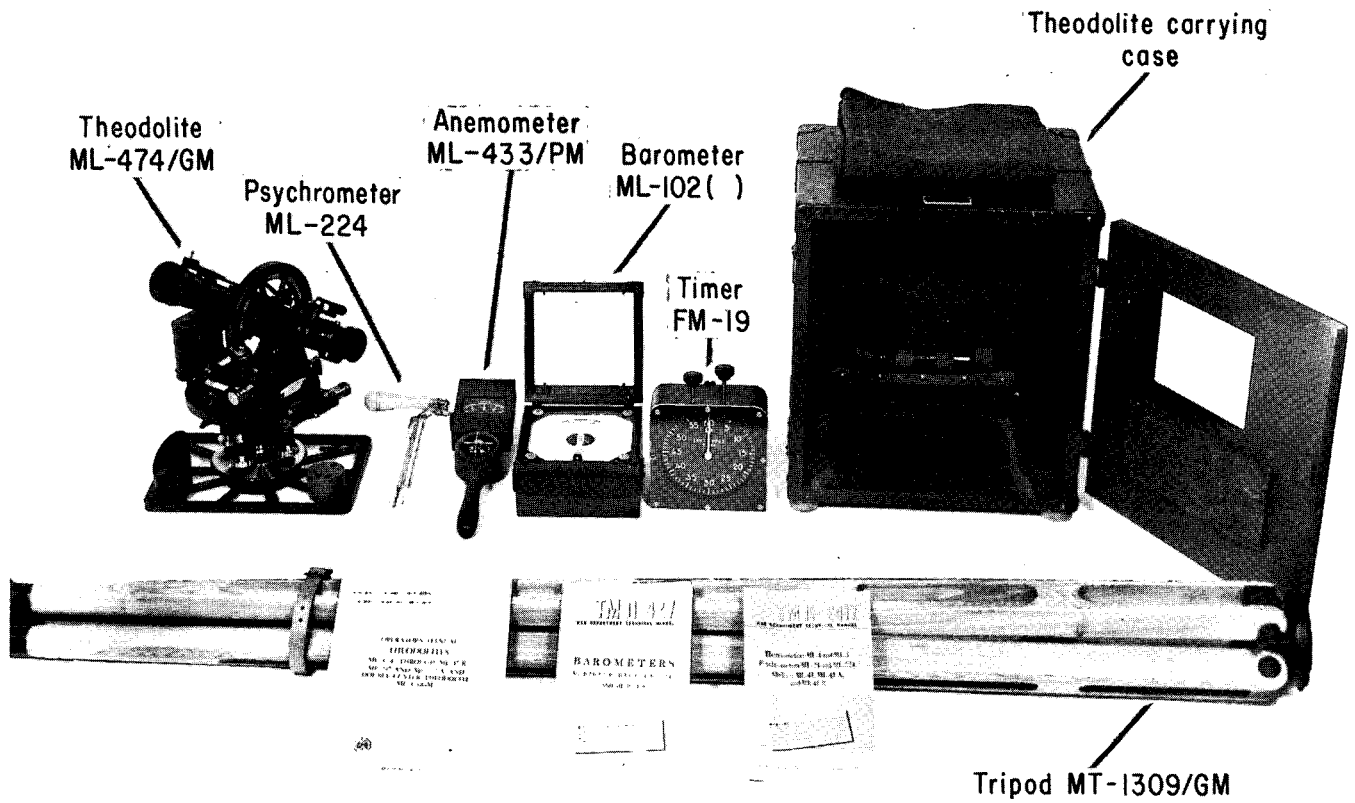

Figure 24. Surface observation equipment.

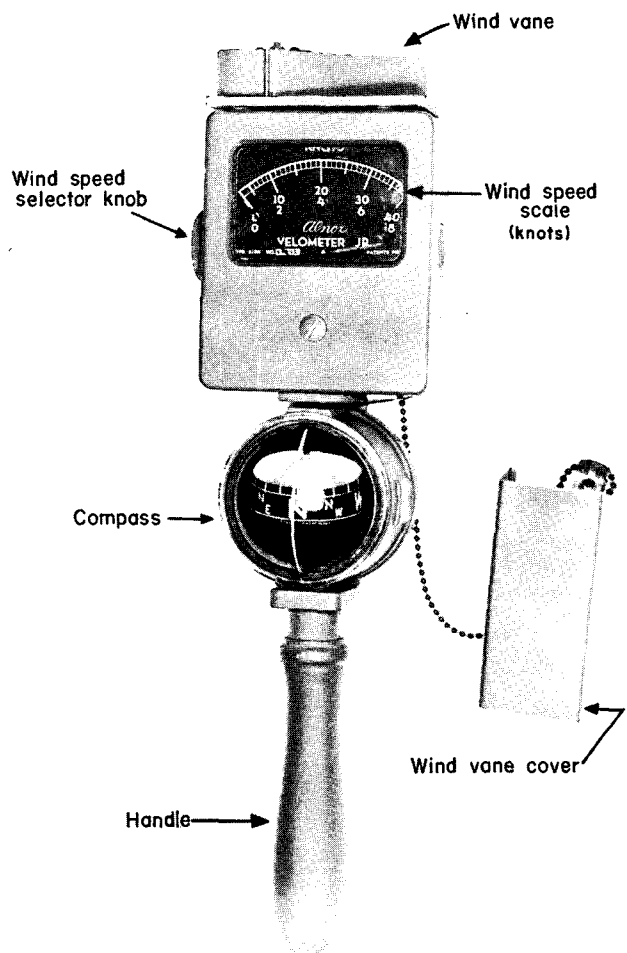
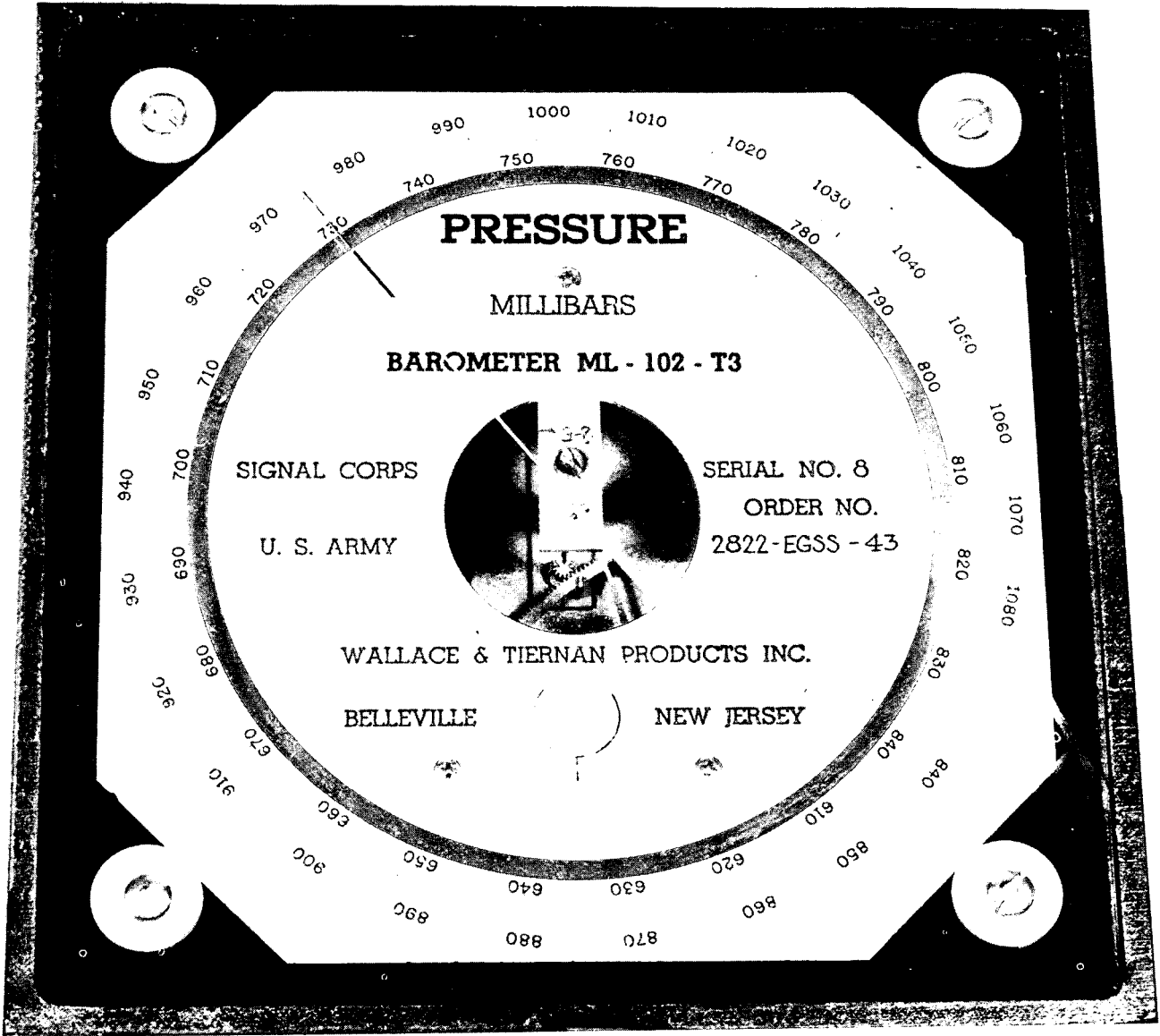
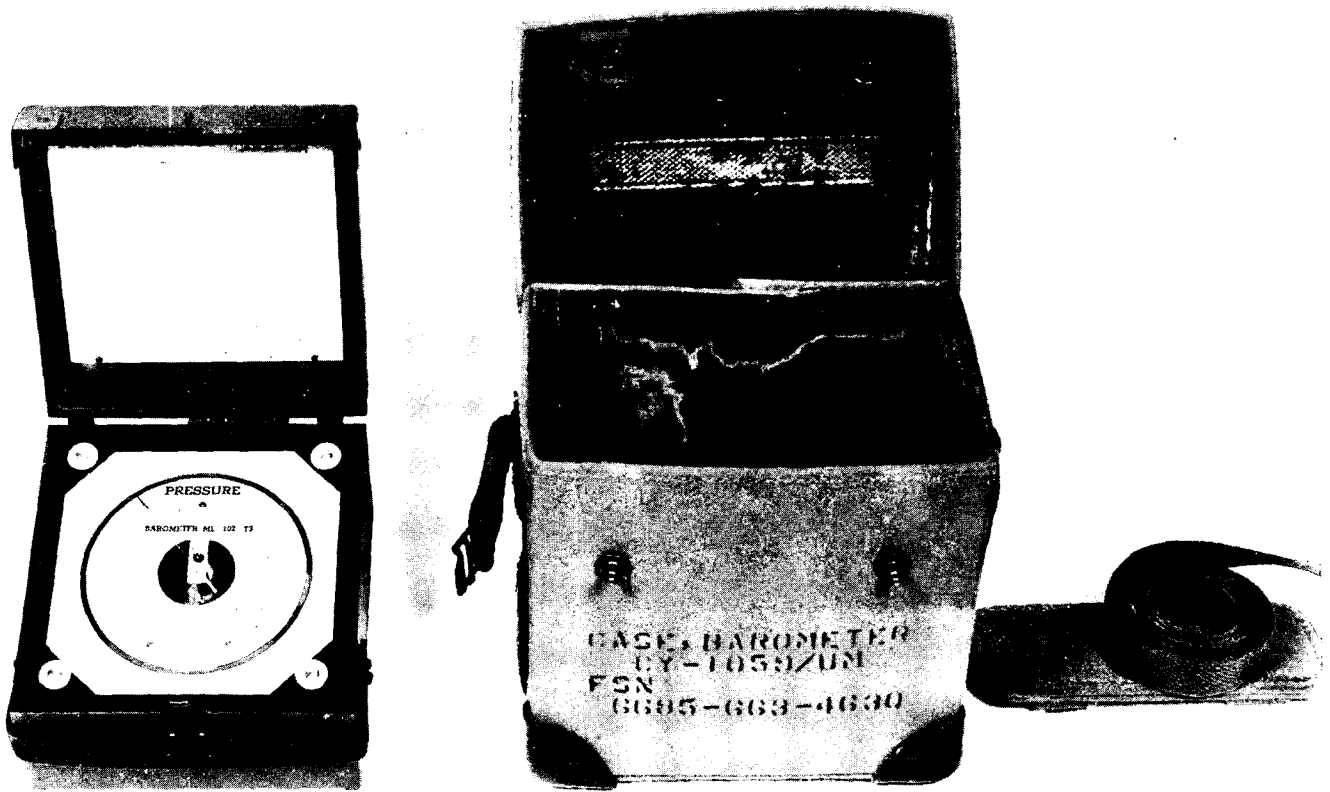

Figure 25. Anemometer ML-433/PM.



① Barometer ML-102-().

Figure 26. Barometers ML-102-() and ML-333/TM.



② Barometer ML-102-()—Continued.

Figure 26—Continued.

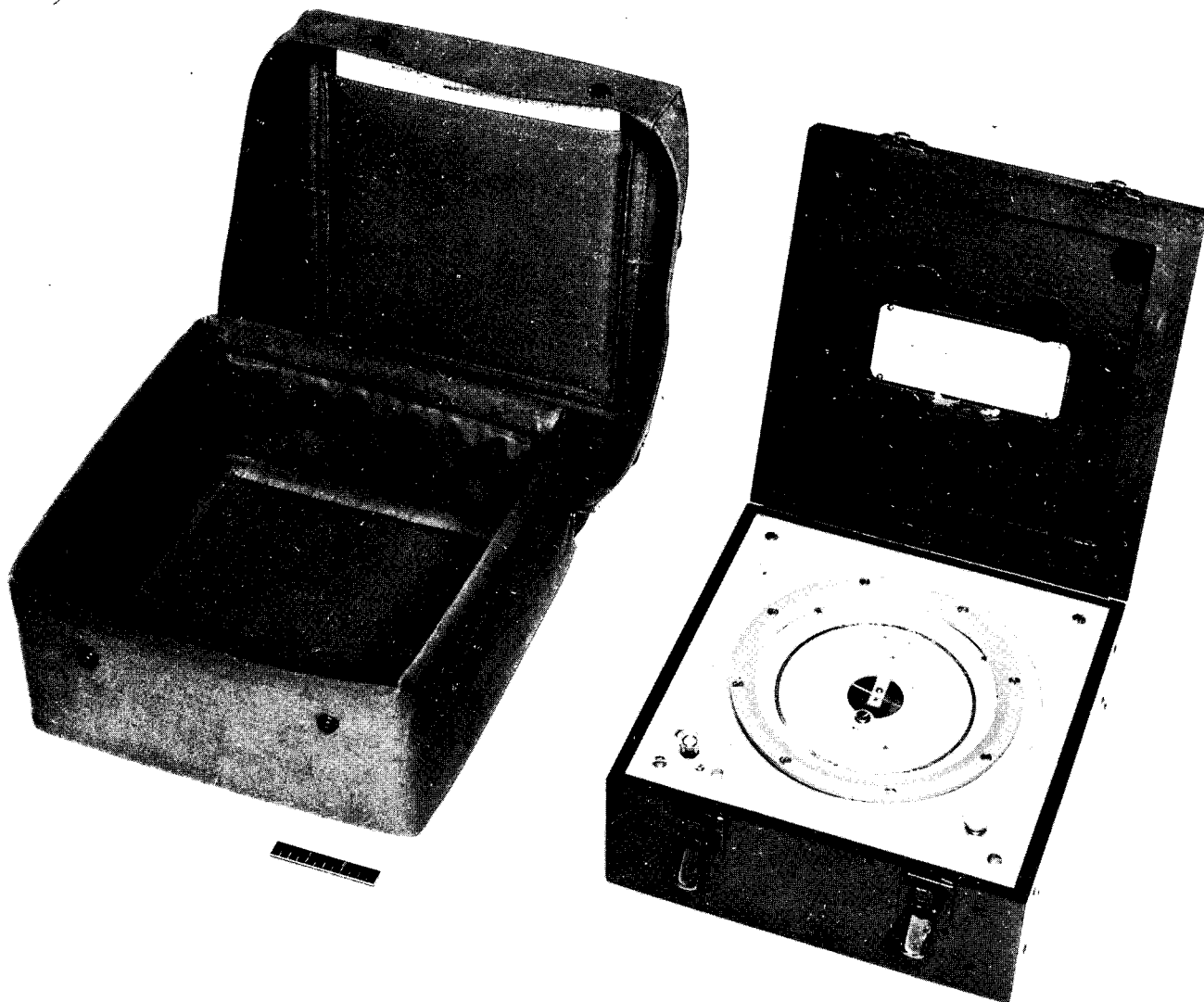

③ Barometer ML-333/TM.

Figure 26—Continued.

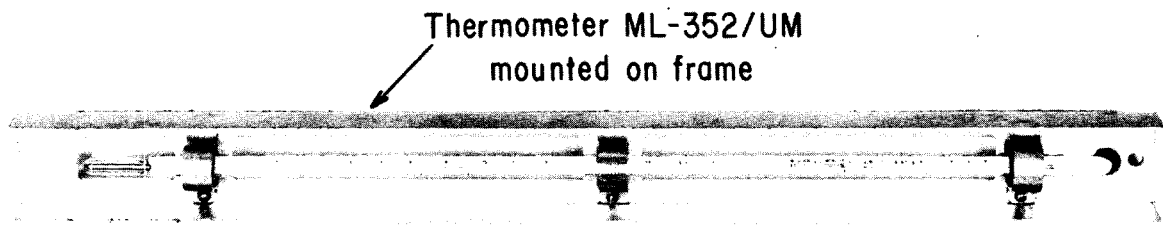
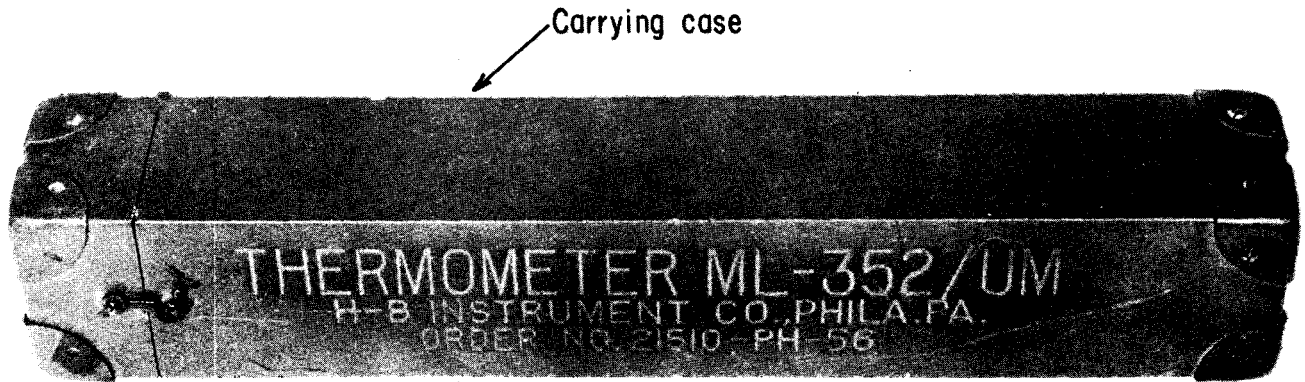

Figure 27. Thermometer ML-352/UM.

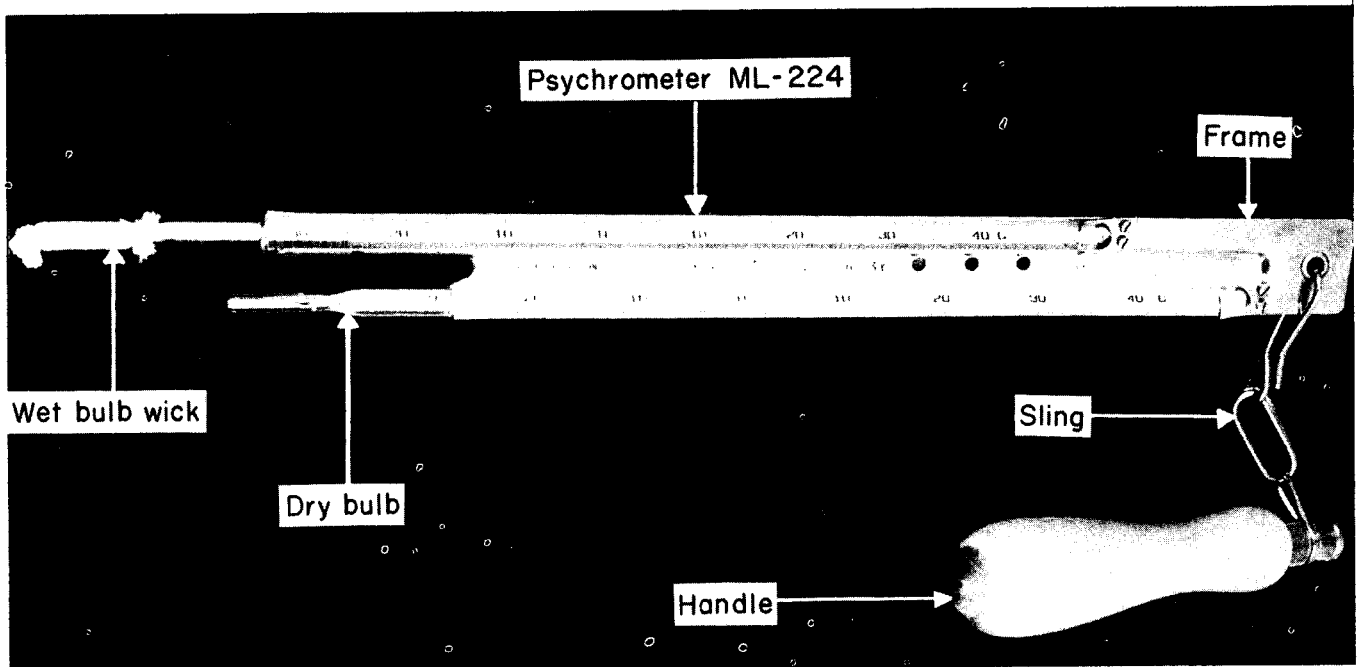

Figure 28. Psychrometer ML-224.

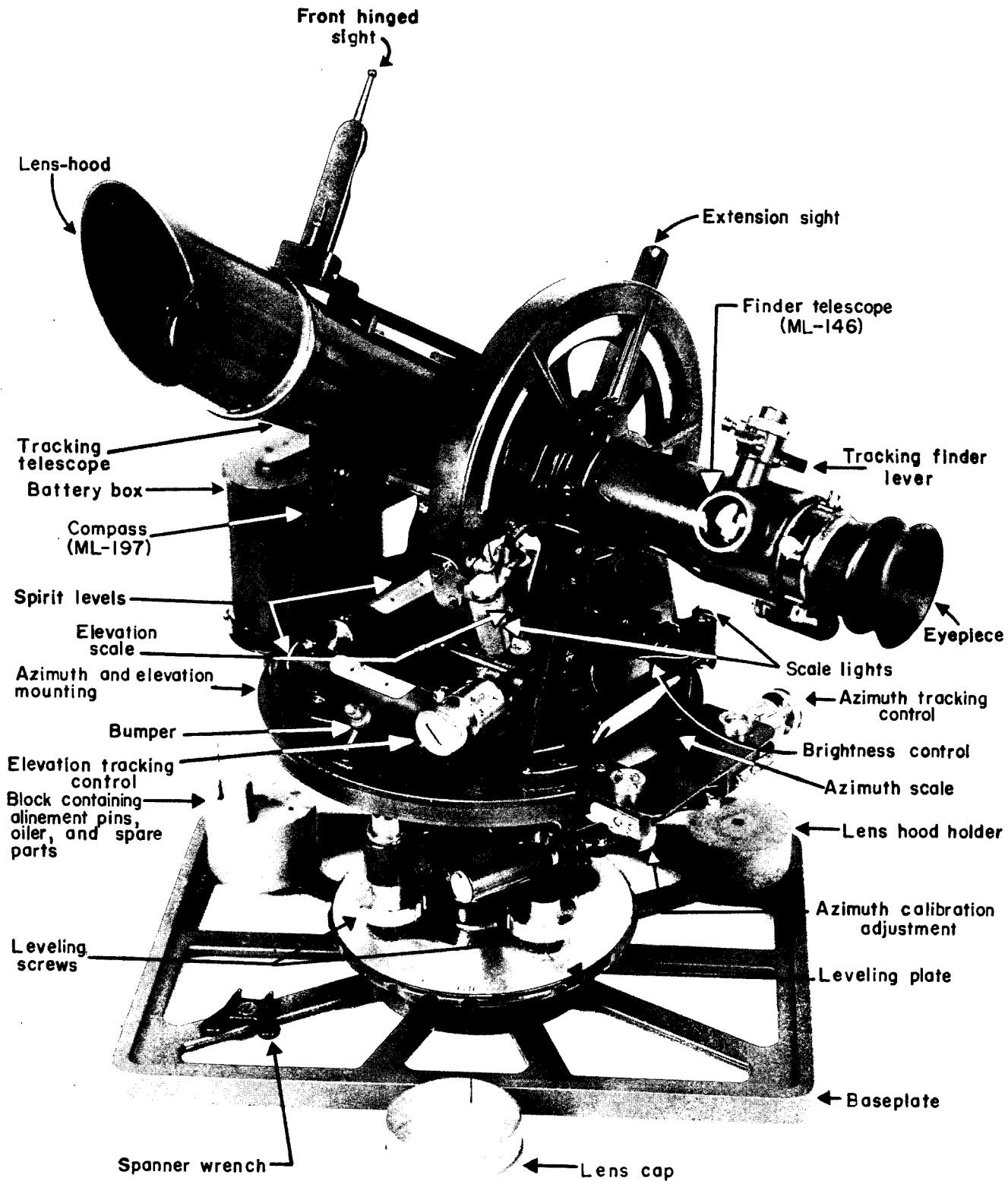

Figure 29. Theodolite ML-474/GM.

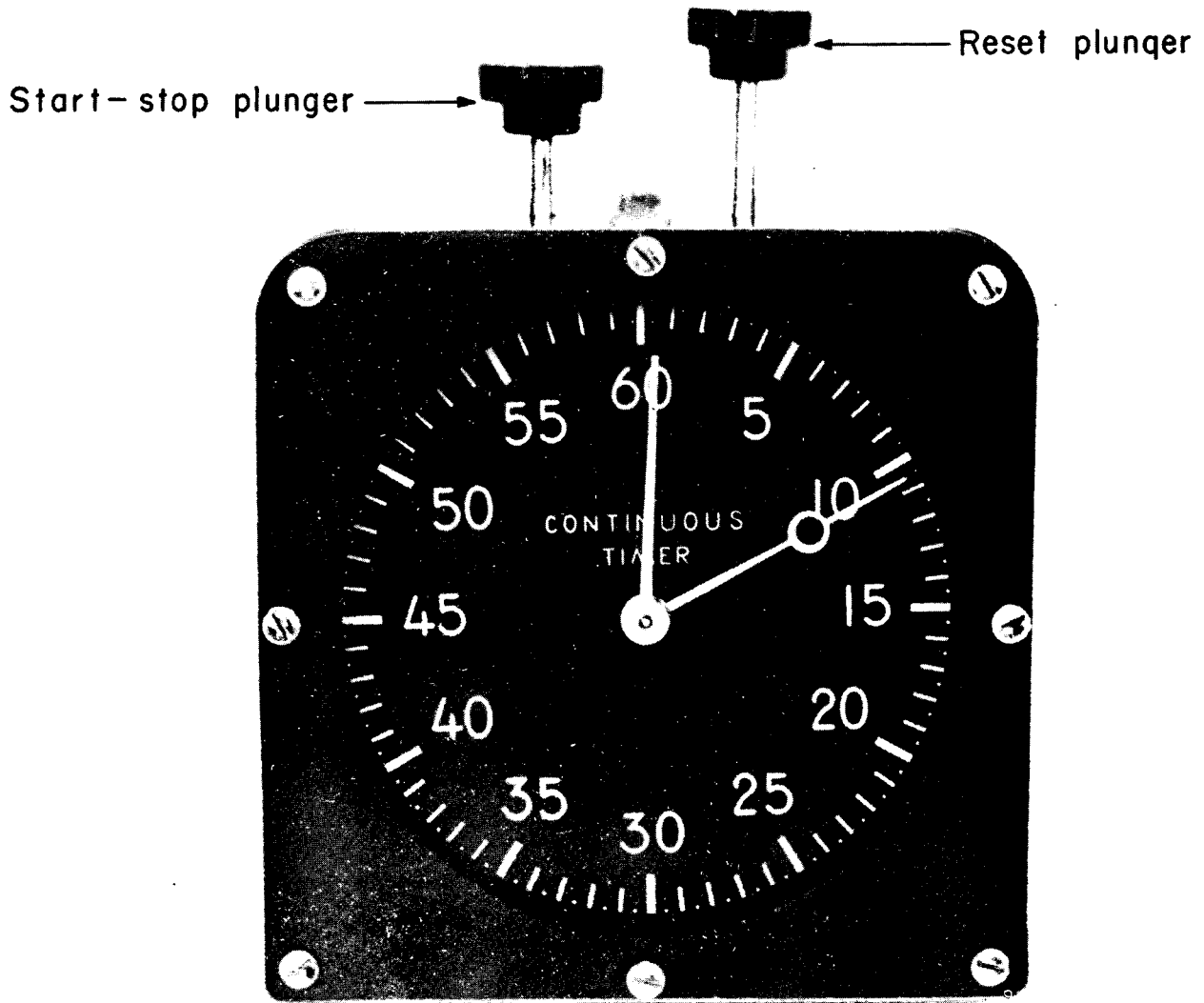

Figure 30. Timer FM-19.

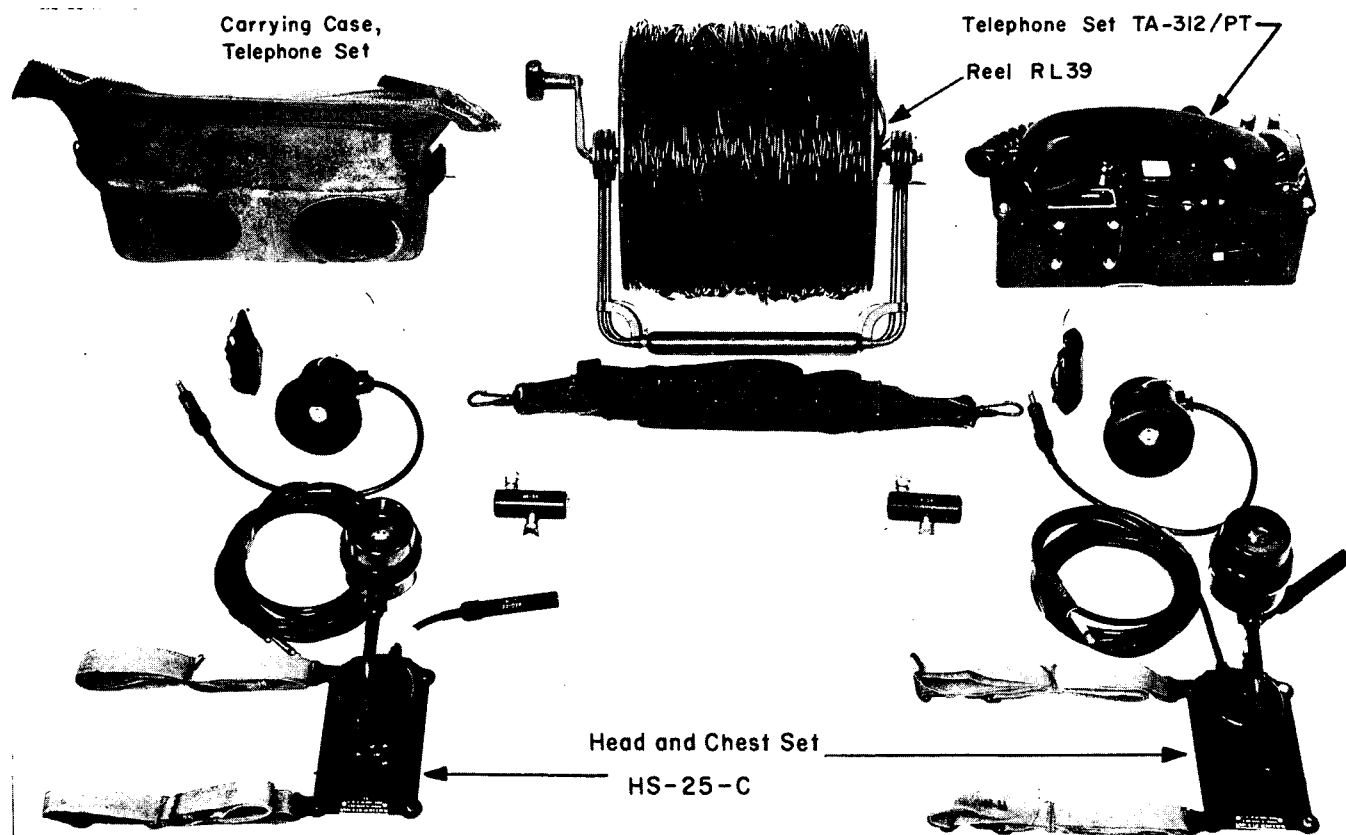

Figure 31. Wire communication equipment.

Section II. SURFACE OBSERVATION EQUIPMENT

49. Anemometer ML-433/PM

a. Purpose. Anemometer ML-433/PM (fig 25) is an instrument used for measuring surface winds. The anemometer provides the means for measuring both the direction and speed of the wind at the time the balloon is released.

b. Description. The anemometer consists of a wind vane with a removable cover, a velometer, a magnetic compass, and a removable handle. The velometer measures the wind speed in knots, and the 16-point compass measures the wind direction from magnetic north. An index pin adjacent to an index mark on the wind vane is used to align the vane with the wind direction. The velometer, on which the wind vane is mounted, has a knurled range selector knob on the left side and a screened vent on the right side. Two windspeed ranges, 0-8 and 0-40, are marked near the knob. The velometer scale is graduated in knots, the upper scale from 0 to 40 and the lower scale from 0 to 8. A pointer moves over the scale to indicate

wind speed. Under the velometer is a compass, which is mounted so that magnetic wind direction will be read directly when the observer faces the compass. For other features of the anemometer, see figure 25.

c. Use. Wind *direction* is determined by slowly turning the anemometer clockwise and counter-clockwise until the index mark on the vane is aligned with the index pin. Then the wind direction is read on the compass. The compass reading is the wind direction in relation to magnetic north and must be converted to direction in relation to true north by applying the local magnetic declination constant. The magnitude of the declination correction for a particular station should be determined by the section chief. If a shifting wind makes reading the compass difficult, two extreme compass readings are averaged. The wind direction read on the compass, is converted to tens of degrees from true north; then the degrees are converted to mils (table II, FM 6-16). Refer

to paragraph 169 (fig 118) for the relation between compass points and mils. To determine the wind *speed*, the index mark on the range selector knob is set to the appropriate wind speed range, 0-8 (gentle winds) or 0-40 (strong winds). With the anemometer in the same position in which it was held to read the wind direction, the wind speed is read on the velometer scale. The scale pointer must be viewed at a right angle to avoid parallax. Note that the wind speed is read in whole knots. If the pointer fluctuates considerably, the high and low points are read and the two readings are averaged and recorded.

d. Preventive Maintenance. The cover is kept on the wind vane when the anemometer is not in use. A dry brush is used to clean any dust and grit from the accessible parts or moving elements, and the surface of the anemometer is cleaned with a dry, lint-free cloth. Since the compass is magnetic, it should not be placed near any magnetized objects. Detailed instructions on the characteristics, maintenance, and adjustments are in a special booklet issued with the anemometer.

50. Barometer ML-102()

a. Purpose. The purpose of the barometer (① and ②, fig 26) is to measure the pressure of the atmosphere at the meteorological datum plane.

b. Description and Theory of Operation. Artillery meteorological sections are equipped with an aneroid barometer. In the aneroid barometer is a small metal cell, exhausted of all but a small amount of air and sealed so that changes in the external air pressure cause the cell to expand or contract. The movement of the cell, magnified through a gear and linkage system, is indicated on a dial calibrated in units of pressure, usually millibars (mb). The accuracy of the pressure indicated is subject to irregularities in the elasticity of the cell, the effect of temperature variations, and other errors. The random error of the aneroid barometer is plus or minus 0.3 of a millibar. See TM 11-427 for details of the various models of barometer ML-102.

c. Use. The barometer is usually installed indoors. It should not be placed in the sun or near a draft or heat source but in a place where the temperature remains as constant as possible. The barometer is read in either the horizontal or vertical position, as specified for the particular model. The plastic window of the dial scale is lightly tapped just before reading to insure that the pointer is free to move. The eye is alined over the pointer so that the pointer reflection in the mirror is obscured by the pointer itself. The pressure

is read to the nearest 0.1 millibar and recorded to the nearest 1.0 millibar. When the temperature correction exceeds 0.1 millibar, as determined from the temperature correction chart in the barometer cover, the correction must be applied.

Caution: If the barometer is transported by air or otherwise undergoes a rapid pressure change of 100 mb. or more, wait at least 24 hours before taking a reading. If a met message must be determined shortly after movement by air, the barometer may be used if barometric data are not otherwise available. However, errors may exist in ballistic density values thus determined, and a notation of this fact should be made on the met message form.

d. Preventive Maintenance. The barometer dial face is cleaned with a damp cloth and occasionally polished with a thin coat of wax. The barometer instrument case should never be opened, and the parts never lubricated. Every 90 days the aneroid barometer should be calibrated by comparing it with a standard mercurial or aneroid barometer of known accuracy. When the error is more than 0.3 millibar, the position of the pointer is adjusted by turning the adjustment screw. An average of several pressure readings taken over a period of several hours will give a more accurate correction than a single pressure reading. Standard barometers are found at the field artillery target acquisition battalion (FATAB) meteorological section and at most installations of the Air Weather Service, United States Air Force.

51. Standard Barometer ML-333/TM

a. Purpose. Barometer ML-333/TM (③, fig 26) is issued to a met section of the field artillery target acquisition battalion for use in calibrating the barometers in the corps artillery.

b. Description. Barometer ML-333/TM consists of a metal case which contains the aneroid mechanism shock-mounted in a hardwood mounting case. A padded canvas carrying case is provided for hand-carrying the barometer. The metal case containing the aneroid mechanism is kettle-shaped (8 inches in diameter by 4 inches deep) and is made of aluminum alloy. A sealed plate glass cover protects the dial. An opening in the glass cover permits adjustment of the pointer without opening the case. This opening is plugged by means of a threaded metal sleeve with a flanged top cemented into the glass. The hardwood mounting case is 11 inches square by 5 inches deep. The metal case is held in the hardwood mounting case by a 10-inch square aluminum plate. A valve is mounted on the underside

of the aluminum plate near the lower right-hand corner, and an air pump is similarly mounted near the lower left-hand corner of the plate. A pushbutton, which operates the valve, projects through to the top of the aluminum plate. The air pump consists of the barrel and plunger of a glass hypodermic syringe provided with a suitable valve to permit air to be pumped either into or out of the metal barometer case. The top of the plunger of this pump projects through the top of the aluminum plate, thus permitting operation of the pump when the lid of the wooden mounting case is raised. Two pieces of rubber tubing connect the valve and the pump to the barometer case. The purpose of the valve is to permit the metal barometer case to be sealed completely from the outside air or opened to the outside air so that the pressure in the case will be equal to that of the outside air. The purpose of the pump is to provide a means of controlling the air pressure within the metal barometer case when the valve is closed and the case is sealed from the outside air.

c. Use and Preventive Maintenance. For use and preventive maintenance, see TM 11-2421.

52. Psychrometer ML-224

a. Purpose. The purpose of the psychrometer ML-224 (fig 28) is to provide a means for measuring the wet- and dry-bulb temperatures of the air. From these measurements, the water vapor content of the air may be determined.

b. Description and Theory of Operation. Psychrometer ML-224 consists of two 9-inch mercury-in-glass thermometers of the same type (general or tropical) mounted on a metal frame which is attached by means of a small chain to a wooden handle. The general-type thermometers are graduated in degrees Celsius from -37° to $+46^{\circ}$. One thermometer (wet-bulb), with the bulb covered by a small cotton wick to hold water, is mounted lower on the frame than the other. As water evaporates, it absorbs a fixed amount of heat energy. Thus, as the wetted wick of the wet-bulb thermometer begins to dry, it absorbs heat from the bulb and causes the wet-bulb thermometer to register a lower temperature than the dry-bulb thermometer. This temperature difference is termed the wet-bulb depression. The rate of drying varies with the dryness of the surrounding air, i.e., the relative humidity (RH) of the air. Dry air (zero RH) causes the maximum evaporation to occur and, likewise, the maximum depression. The wet-bulb depression and the dry-bulb reading are commonly used as arguments to

enter tables used to obtain the virtual temperature and relative humidity of the air. See TM 11-6660-222-12 for detailed information on psychrometer ML-224.

c. Use. The psychrometer is ventilated in the shade or an instrument shelter, when possible, to obtain the air temperature, since direct sunrays and precipitation cause erroneous readings. The operator ventilates the psychrometer, as pictured in figure 32, to eliminate the effect of body heat. The thermometers are never handled because hand heat affects the readings. The operator wets the wick in clean water—in distilled water when possible or in rainwater that is free of all mineral matter. The operator whirls the psychrometer for about 15 seconds and reads the wet-bulb thermometer. He repeats the process at 10-second intervals until the wet-bulb thermometer changes less than 1° between readings; then he repeats the process at 5-second intervals until a minimum wet-bulb reading is reached. He records the wet-bulb reading and the concurrent dry-bulb reading to the nearest 0.1° C. The dry-bulb temperature is the air temperature. When the psychrometer is used in high temperatures or very dry air, the wick is wetted thoroughly and a drop of water is allowed to stand on the bulb for several minutes to precool it. This precooling permits completion of the observation before the wick dries out completely. When the psychrometer is used at temperatures below freezing, the wick is wetted 10 to 15 minutes before use so that the heat of fusion of the ice will be dissipated before the observation is made. With the wick frozen in a thin coating of ice, the operator proceeds with the observation. After the observation, the wet-bulb depression is determined. This depression and the dry-bulb reading are used as arguments to enter the relative humidity chart (chart VIII, FM 6-16) to determine the percentage of relative humidity. The values of relative humidity given in chart VIII are with respect to water at all temperatures. At temperatures above freezing, if the air is saturated, no evaporation from the wet-bulb thermometer can occur, and the wet-bulb thermometer reading will be the same as the dry-bulb thermometer reading. If the air is not saturated, the wet-bulb thermometer reading will be lower than the dry-bulb thermometer reading and the relative humidity will be less than 100 percent.

d. Preventive Maintenance. The thermometer tubes are cleaned with a damp cloth and polished with a clean, dry cloth. The frames are cleaned by wiping with a solution of sodium bicarbonate;



Figure 32. Ventilation of psychrometer.

abrasives or acid cleaners are not used. Occasionally, the swivel bearing is oiled and the linkage is checked for free movement and good condition. The wet-bulb wick is changed monthly or more often in areas where there is excessive dust or other air pollution. Errors due to inaccuracies in the thermometers can be eliminated by compar-

ing the thermometer when issued, selecting two that have readings most nearly the same at the same temperature, and mounting these two on the same psychrometer frame. If there is no standard thermometer available, the reading of the dry-bulb thermometer should be accepted as correct, and the reading of the wet-bulb thermometer should be corrected to that of the dry-bulb thermometer. If a standard thermometer is available, all thermometers should be compared to determine the scale error. For detailed information on maintenance, see TM 11-6660-222-12.

53. Theodolite ML-247 or ML-474/GM

a. Purpose. The purpose of theodolite ML-247 or ML-474/GM (fig 29) is to provide a means of visually tracking a pilot balloon in flight. The elevation and azimuth scales indicate the angles to the balloon. Changes in the position of the balloon observed at regular intervals are indicative of the wind speed and direction.

b. Description. Theodolites ML-247 and ML-474/GM are identical except for the manner in which the crosshair is illuminated. The theodolite is a precision-built optical instrument and is usually mounted on tripod ML-78 or MT-1309/GM. The main components of the theodolite are a tracking telescope, a finder telescope, and a set of open sights, arranged in conjunction with the azimuth and elevation scales. The tracking telescope of the theodolite has a 20-power magnification and a 2° field of view; it can be rotated 360° in azimuth and plunged in elevation. A finder telescope of 4-power magnification and 10° field of view is mounted parallel to the tracking telescope in the eyepiece tube. The theodolite is equipped with a compass and, when properly declinated, can be oriented on true north. The elevation and azimuth scales are in 1° graduations. The drum micrometers of the azimuth and elevation tracking controls are in 0.1° graduations. By interpolation on the drum micrometer scale, readings may be made to the nearest 0.01°. See TM 11-6675-200-10 for details on operation of the theodolite.

c. Use. The theodolite should be located where there are no obstructions above an elevation angle of 3°. A windbreak is desirable, since wind gusts may upset the tripod. The operator must emplace the tripod firmly in the ground and level the instrument prior to use. Elevation and azimuth readings to a pilot balloon are determined by tracking the balloon with the theodolite and reporting the required readings at proper intervals.

d. Orientation Methods. The theodolite may be oriented by compass, survey data, the sun, Polaris, equal angles, datum lines, or transference. TM 11-6675-200-10 describes each of these methods. The two most common methods of orientation are by survey data and by compass.

★(1) *Orientation from survey data.* Orientation of the theodolite by using survey data is considered the primary method. When this method is used, the met section chief coordinates with the survey personnel who provide the orientation data. Survey control, when available, consists of the correct grid azimuth from the theodolite position to a fixed reference point and the altitude of the theodolite to the nearest 10 meters. Orientation from survey data is more accurate than the magnetic orientation and should be used as soon as survey data are available. The theodolite operator first converts the grid azimuth to true azimuth, then sets the true azimuth on the instrument. He next loosens the azimuth calibration clamp and sights through his main telescope on the reference point. The azimuth calibration clamp is then tightened and the final adjustment made with the azimuth calibration screw. The theodolite is accurately oriented on true north.

(2) *Orientation by a compass.* When the theodolite is oriented by a compass, the local magnetic declination is obtained from the survey information center or from the marginal data of a map of the area. The magnetic North Pole of the earth (toward which the north seeking end of a compass needle points) does not coincide with the earth's geographical north pole (true north). Consequently, a compass seldom indicates the true north direction but deviates from it by varying amounts depending on its location and other factors. The extent of this deviation is known as magnetic declination, and must be known for a particular place before a theodolite can be oriented by a compass. The steps for orienting a theodolite by compass are as follows:

(a) Disengage the azimuth tracking control and rotate the mounting until the fiducial marker of the azimuth scale is aligned with the magnetic setting. Then engage the tracking control. This setting will be 0° plus the deviation for an East declination (magnetic direction arrow to the east of true north) or 360° minus the deviation for a West declination (magnetic direction arrow to the west of true north). For example, if the declination is 5° E, set the fiducial mark opposite the 5° graduation of the azimuth scale; if the declination is 5° W, set the mark opposite the 355° graduation.

(b) Loosen the azimuth calibration clamp and lower the lock lever on the side of the compass.

(c) Rotate the mounting until the compass needle is approximately over the S mark on the compass face.

(d) Tighten the azimuth calibration clamp and turn the azimuth calibration adjustment until the needle is exactly over the S mark.

(e) Raise the compass lock lever to its upper position to secure the internal mechanism.

(f) The theodolite is now oriented on true north.

e. Preventive Maintenance. The theodolite is a delicate instrument and must be carefully protected from jarring, dirt, and unnecessary exposure to the weather. Extreme care should be exercised in removing it from or returning it to the carrying case. When mounted on the tripod, the theodolite should not be left unattended for an excessive period of time. While on the tripod and not in use, it should be covered with the canvas hood. The magnetic needle requires declination at periodic intervals, especially under field conditions where movement is involved. For detailed instructions, see FM 6-2. The theodolite should be inspected daily for loose parts, which should be tightened. For specific instructions on organizational maintenance, see TM 11-6675-200-20. Details on operator's preventive maintenance are contained in TM 11-6675-200-10.

Caution: Care should be taken in adjusting brass screws which are soft and easily damaged.

54. Timer FM-19

a. Purpose. The purpose of the timer FM-19 (fig. 30) is to time the flights of pilot balloons so that the azimuth and elevation angle readings will be taken at the proper times.

b. Description. The timer FM-19 is a conventional timer with a circular dial graduated from 0 to 60 minutes and marked at 5-minute intervals. It contains a long sweep second hand and a shorter minute hand. The start-stop and reset plungers are side by side on the top of the timer. A latch for rewinding is on the back. The timer is spring powered and should be wound before each balloon flight.

c. Use. After the timer is wound, the start-stop plunger is pressed to insure that the second hand is functioning properly. The start-stop plunger is pressed again to stop the hands, and the reset plunger is pressed. The timer is now ready for operation. The start-stop plunger is

pressed at the instant the pilot balloon is released.

d. Preventive Maintenance. The face of the timer should be kept clean at all times to insure accurate readings. The timer should be handled

with care in order to prevent jarring which might damage its operating mechanism. Regular checks and adjustments should be made by comparing the timer with an accurate watch.

Section III. INFLATION EQUIPMENT AND BALLOONS

55. Balloon Inflation and Launching Device

a. Purpose. Balloon inflation and launching device ML-594/U (fig. 33) is designed to secure and protect meteorological balloons during inflation and launching. Effective meteorological forecasting data from many levels of the earth's atmosphere is obtained with the help of meteorological balloons of various types and performance characteristics. The meteorological balloons are fabricated of highly elastic compounds which are easily punctured; therefore, they are highly vulnerable to damage during inflation and launching operations, particularly when these operations are accomplished during extreme weather conditions such as strong winds, heavy rain, snow, ice, or other heavy precipitation.

★*b. Use.* Balloon inflation and launching device ML-594/U is a portable inflation shelter and launching platform designed for use in the field. It is used with a hydrogen-helium volume meter ML-605/U and a compressed gas supply. The device is used to secure the balloon during inflation and protect it from extremes of weather.

c. Preventive Maintenance. Detailed procedures for operation and preventive maintenance of the ML-594/U and the ML-605/U are contained in TM 11-6660-238-15 and TM 11-6660-245-15 respectively.

56. Gases Used for Inflation

Pilot and sounding balloons are inflated with either hydrogen or helium gas. The met section has the capability of producing hydrogen in the field by using calcium hydride charges. Calcium hydride reacts chemically with water to produce hydrogen gas. The calcium hydride method of preparing hydrogen for inflation of balloons is essential to self-sufficient operation of the met section. However, commercial hydrogen and helium have many advantages and should be used if available. These gases are supplied commercially in high-pressure, steel cylinders which contain approximately 200 cubic feet of gas. Regulator ML-193 (ML-528/GM) (fig. 34), a component of meteorological station, manual AN/TMQ-4, is

used to reduce the high pressure of the gas in the cylinder to a suitable pressure for balloon inflation. The use of commercial gases is more economical, reduces inflation time, requires no water, and is more convenient to handle. Commercial hydrogen (Federal stock number 6830-264-6748) and helium (Federal stock number 6830-660-0027) are procured through engineer supply channels. Commercial hydrogen has been economically used by met sections in the continental United States, England, Germany, Korea and Vietnam. Even though commercial hydrogen, is used, the met section will continue to stock calcium hydride charges at the authorized TOE level for use during emergencies. For training purposes, it is recommended that every tenth sounding balloon be inflated with hydrogen generated by the calcium hydride method. Because it is inert and not explosive, helium is preferred to hydrogen. Unfortunately, helium is not available in many parts of the world and, when available, is supplied in cylinders only. Helium is usually cheaper than hydrogen prepared with calcium hydride. Because helium is heavier than hydrogen, more helium is required to attain the same rate of rise as hydrogen.

Note. When calcium hydride is used, the hydrogen-helium volume meter ML-605/U will not be used.

57. Safety Procedures

a. Both the generation and use of hydrogen are dangerous due to the highly inflammable nature of the gas. Only by workers being extremely careful can the dangers of fire or explosion be minimized. Because of the hazards involved in handling hydrogen, helium (an inert gas) should be used to inflate balloons when it is available. When hydrogen is used, the safety precautions outlined in chapter 33 must be carefully observed. Copper wire should be used to connect all metal parts of the equipment to each other and to a well-grounded object, such as a ground rod. Ground clamps or alligator clips are used to connect the wire to the metal. For a good connection, the metal surfaces should first be cleaned with



Figure 33. Balloon Inflation Launching Device
ML-594/U.

sandpaper. The following grounding procedure is used:

(1) Two ground rods are spaced approximately 6 meters apart and driven into the ground to a depth of 1 meter.

(2) The resistance is measured between the two rods with an ohmmeter by connecting the two rods electrically and using the pair as a ground to determine whether the resistance is 1,000 ohms or less.

(3) If the resistance is greater than 1,000 ohms, another pair of rods is driven into the ground to form two rows of rods. The rows are 6 meters apart, and the distance between each rod in a row is approximately 1.5 meters.

(4) The two rows are connected electrically, and the combination is used as a ground to determine whether the resistance is 1,000 ohms or less. A rod is added to each row at

1.5-meter intervals until the resistance between the rows is 1,000 ohms or less, and the final combination is used as a ground.

(5) Personnel in the immediate area where hydrogen is being generated should be grounded by using the issued grounding strap assemblies. A path to ground for static electricity is particularly important for the individual actually handling the balloon (fig 35).

b. When calcium hydride charges are used, each charge is inspected to insure that no corrosion exists along the sealed seams of the container. If any corrosion is present, *the charge is not used*. Corrosion indicates the possibility that moisture has leaked inside the container, and an explosion may result if a spark is caused by the hand punch used to open the charge. In most cases, but not always, the calcium hydride charge will bulge slightly if moisture has leaked inside

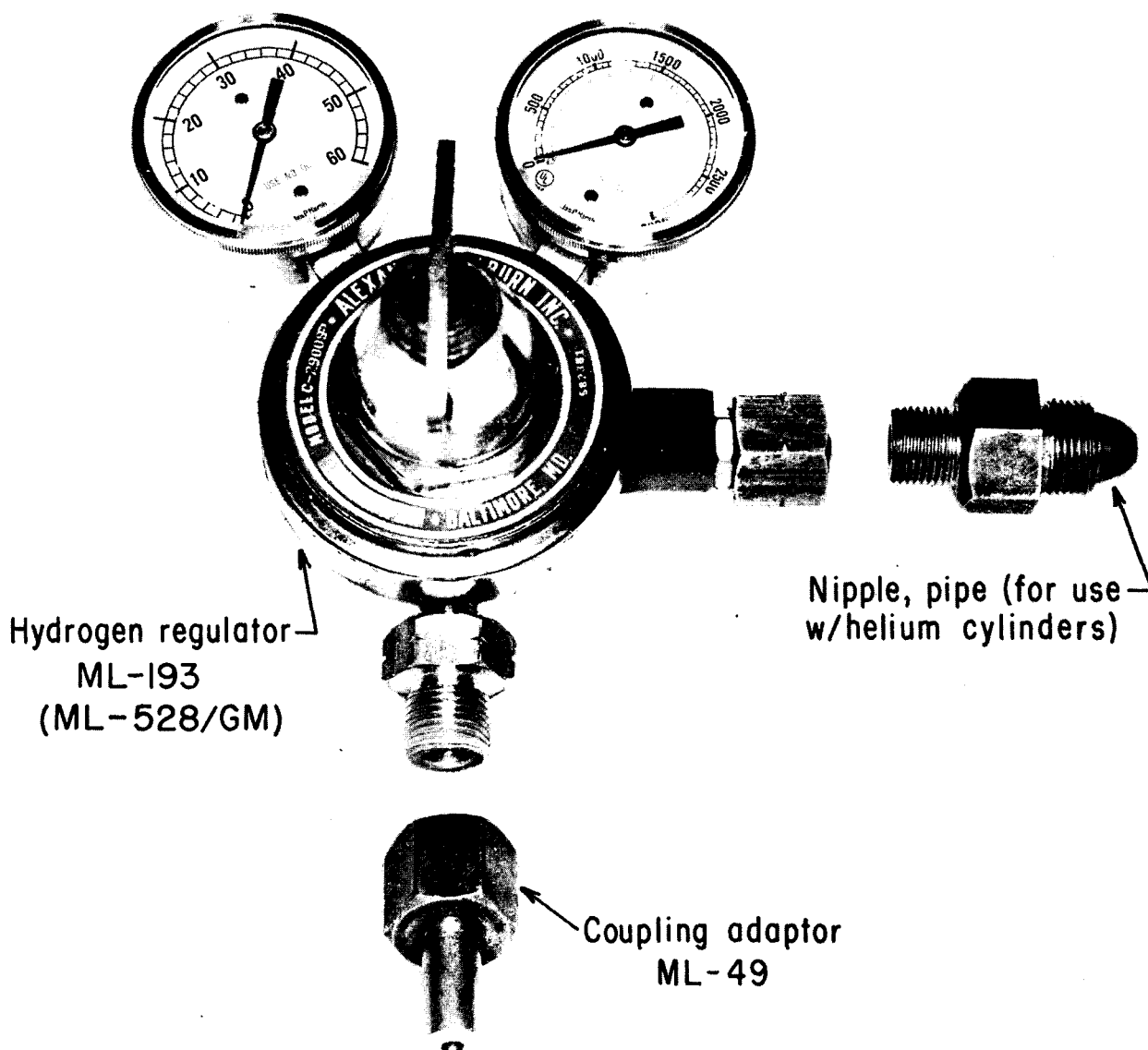

Figure 34. Regulator ML-193 with accessories.

and formed a small amount of hydrogen. Calcium hydride in powder form is highly subject to explosion from static electricity. If, while gently shaking an opened charge, it is observed that the contents are not in a crystal or lump form, *the charge is not used*. Defective charges should be buried.

58. Hydrogen Generators

a. *Hydrogen Generator ML-303/TM*. The purpose of the hydrogen generator ML-303/TM (fig 36) is to provide a means for producing hydrogen gas in the field for inflation of 30- and 100-gram

pilot balloons. The hydrogen generator consists of an outlet tube for attaching hose ML-81, a punch to open the knockout holes in calcium hydride charges, and a generator body which provides a pressure chamber for the generated gas. In the field, the calcium hydride charge fastened to the bottom of the generator body reacts chemically with water, in which the generator is immersed, to produce hydrogen gas. Water pressure at the base of the generator minimizes the loss of gas from back pressure, and the expanding gas passes through the outlet tube at the top. A baffle inside the top of the generator prevents water



Figure 35. Grounding of hydrogen generating equipment.

from being forced into the balloon along with the gas. For detailed information, see TM 11-2413. Hose ML-81 is used to conduct the gas from the generator to the inflation nozzle. Calcium hydride charge ML-304A/TM will generate approximately 6 cubic feet of hydrogen, which will inflate the 30-gram pilot balloon. Calcium hydride charge ML-305/TM will generate approximately 24 cubic feet of hydrogen, which will inflate the 100-gram pilot balloon. Care must be taken to ground the hydrogen generator. To allow water to enter the can, the operator must punch out the knockout holes in the top of the calcium hydride charge can. Experience will show how many of the holes should be opened to give rapid, smooth generation. The operator then screws the charge to the bottom of the generator and places the assembly in the water so that the top of the generator is 2 inches above the water. The operator agitates the generator periodically so that the lime produced in the reaction will not clog the can containing the calcium hydride charge and the generator. No harmful by products are produced in this reaction; however, the water will decrease in efficiency as it becomes polluted. Therefore, it may become necessary to use fresh water for each balloon inflation. Any available water may

be used. If any active material remains in the generator after inflation is complete, the operator should leave the generator in the water until the charge is expended. This will prevent lime from clogging the holes and possibly causing an explosion. Care and maintenance of the hydrogen generator consists mainly of thorough cleaning. Best results are obtained if the equipment is cleaned immediately after use. The operator must check the perforations in the bottom of the generator and other parts, including hose ML-81, for clogging. The hose and connections must also be checked for leaks. If deposits of the chemicals in the water harden on the equipment, most of it can be removed with a wire brush.

b. Hydrogen Generator Set AN/TMQ-3. The purpose of hydrogen generator set AN/TMO-3 (fig 37) is to provide a means for producing hydrogen gas in the field for inflation of sounding balloons. The set consists of four generator bodies mounted on a common manifold, two spare generator bodies, a packing case, hoses, and a punch. The manifold consists of a steel tube welded to a square sheet-iron plate. The plate has four holes for mounting four generators ML-303/TM, which are coupled together to permit the generation of hydrogen at four times the rate of a single generator ML-303/TM. Operator maintenance of hydrogen generator set AN/TMQ-3 consists of cleaning the equipment and replacing minor parts.

59. Calcium Hydride Charges ML-304A/TM, and ML-587/TM

Calcium hydride charge ML-304A/TM is an airtight metal can containing approximately 6 ounces of 90-percent pure calcium hydride. The top of the can is recessed and has interrupted threads for attaching the charge to the bottom of the generator body. On the top of the can, there are a number of knockouts which are opened to allow water to enter the can. The charge produces approximately 6 cubic feet of hydrogen. Calcium hydride charges ML-305A/TM and ML-587/TM are the same as charge ML-304A/TM, except in size. Charge ML-305A/TM will produce approximately 24 cubic feet of hydrogen and charge ML-587/T will produce approximately 42 cubic feet of hydrogen.

60. Use of Water for Hydrogen Generator

a. A water container, preferably of metal, is required unless a stream or lake is used. The met

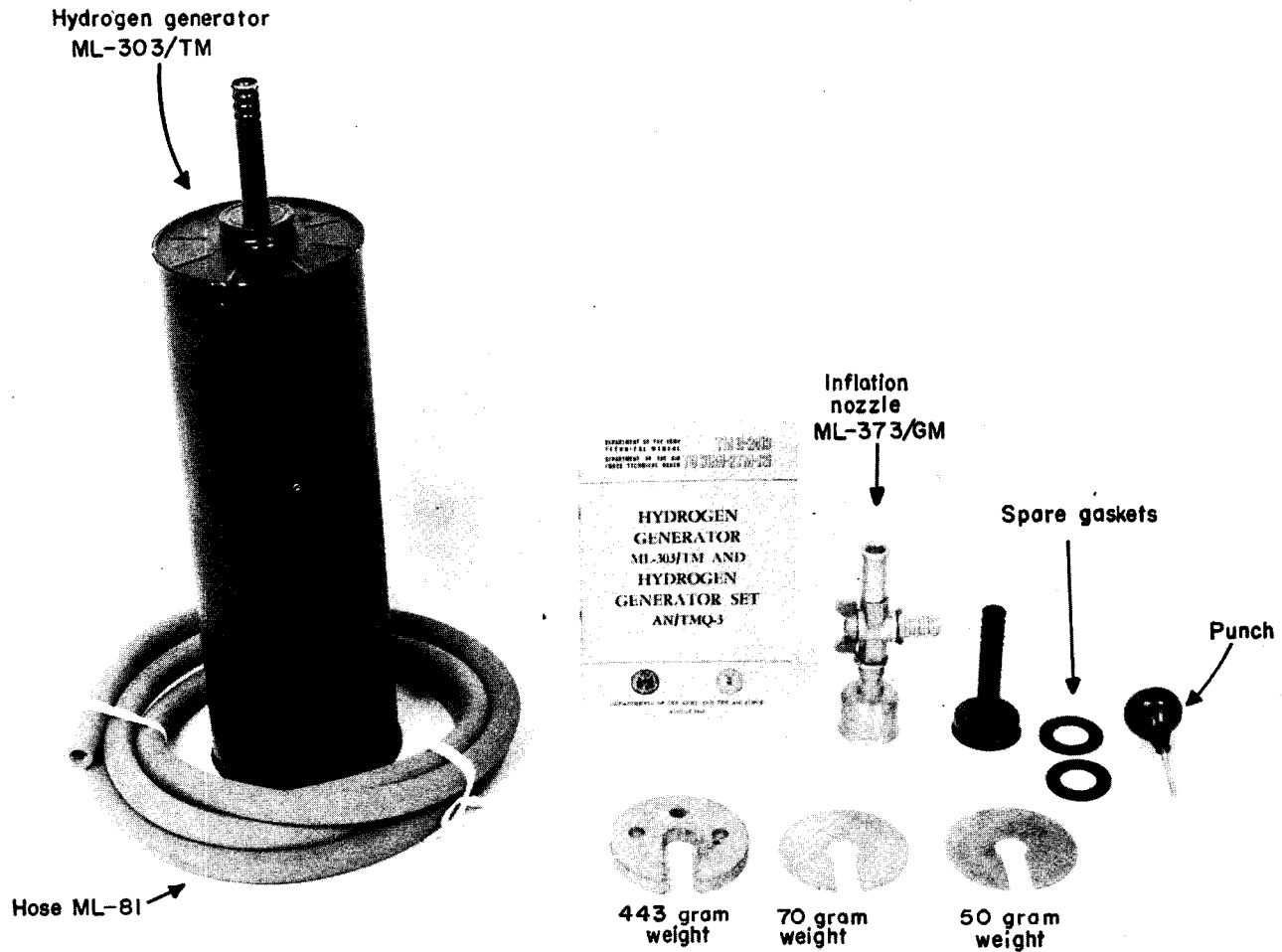

Figure 36. Hydrogen generator ML-303/TM.

section is issued a 32-gallon galvanized can for use with the hydrogen generator.

b. It is desirable to change the water after each generator because the waste chemical products retard the chemical action. The water should also be changed if it has become too hot. Cold water is much more efficient for hydrogen generation than hot water. If water is difficult to obtain, conservation can be accomplished by using more than one container as follows: When water is to be reused, allow it to stand for about 2 hours while using a second container of water. When the waste chemicals in the first container have settled, pour the clear water into a temporary container, clean the first container, and refill it with the water. When a second water container is not available or when it is expedient, the hydrogen generator may be operated in a stream, lake, or other suitable body of water.

61. Bracket Assembly, Antibouyancy

The purpose of the bracket assembly is to firmly hold the hydrogen generator set AN/TMQ-3 in position during inflation. The manifold gas outlet is fastened to an opening in the center if the bracket assembly. The bracket assembly has an adapter on each end so that it can be secured to the top of the corrugated can as shown in figure 38.

62. Balloons

a. Sounding Balloons.

(1) *Purpose and description.* The purpose of sounding balloons is to carry aloft radiosondes and associated equipment, such as a parachute, night lighting unit, and radar reflector. Sounding balloons are made of neoprene and are designed to lift radiosondes to certain minimum altitudes at specified rates of rise.

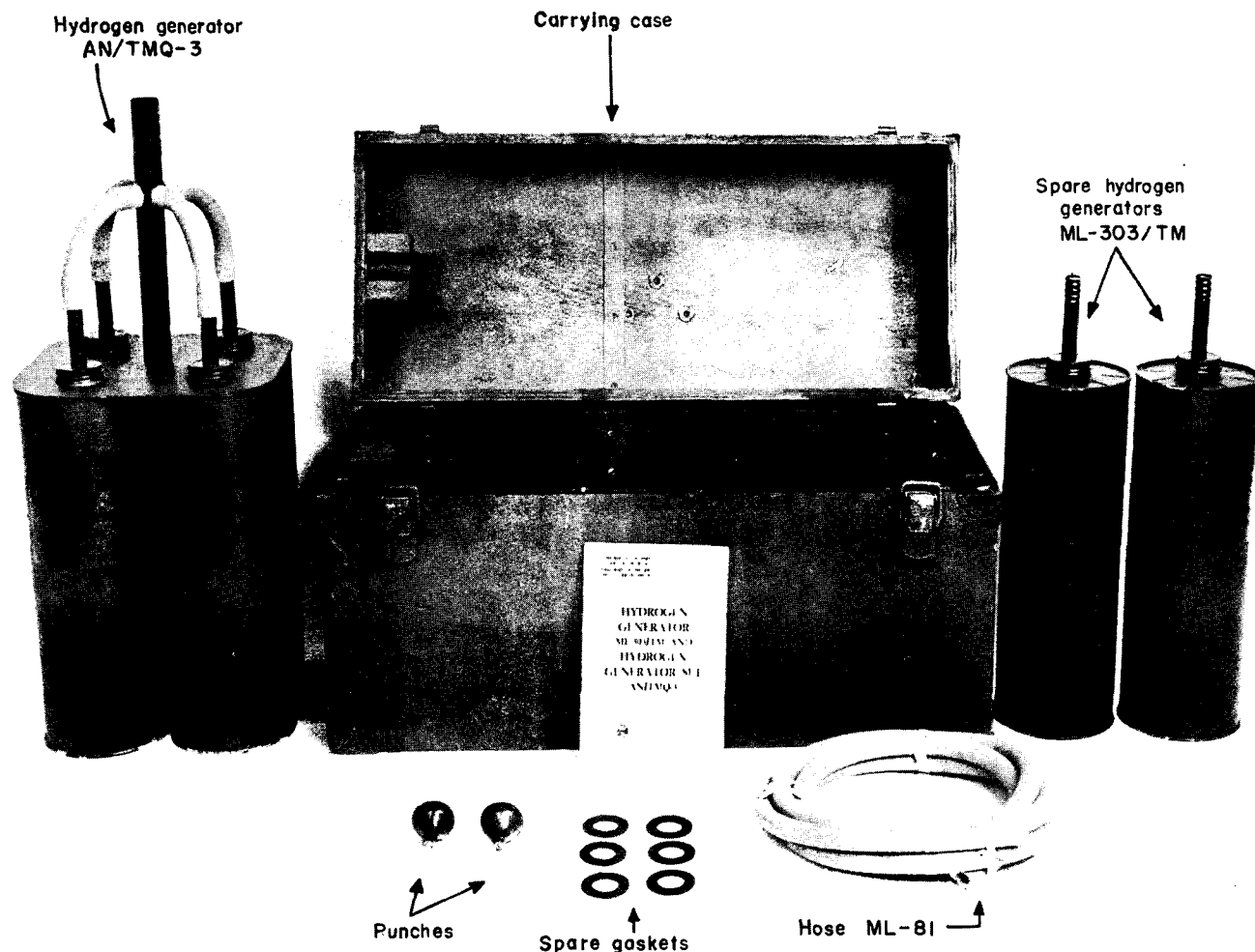

Figure 37. Hydrogen generator set AN/TMQ-3.

(2) *Bursting altitude and rate of rise.* The bursting altitude of a sounding balloon depends on conditioning, inflation procedure, and the type of balloon. High-altitude balloons weigh 1,000 to 1,200 grams and burst near an altitude of 32,000 meters. The fast-rising balloon can rise to an altitude of 23,000 meters at an average rate of rise of approximately 500 meters per minute. At night, the balloons will normally burst at lower altitudes. Bursting altitudes are with respect to mean sea level (MSL). The 100-gram pilot balloon can be used as a sounding balloon up to 3,000 meters and has a rate of rise of approximately 300 meters per minute.

b. Pilot Balloons.

(1) *Purpose.* The purpose of pilot balloons is to provide a means of visually determining the speed and direction of winds aloft.

(2) *Description.* Pilot balloons are issued in two sizes, 30-gram and 100-gram (representing the weights of the deflated balloons). Under various sky conditions, some colors are more easily detected by the eye than others. For this reason, pilot balloons are issued in several colors, the most common being white, red, and black. The rate of rise of the 30-gram balloon is approximately 180 meters per minute, after a steady rate of rise is attained. The rate of rise of a 100-gram balloon is approximately 300 meters per minute, after a steady rate of rise is attained. Under conditions of good visibility and average winds, the 30-gram balloon can usually be observed to a height of approximately 9,000 meters and the 100-gram balloon can be observed to a height of approximately 14,000 meters. These altitudes represent the normal bursting altitudes of the 30-

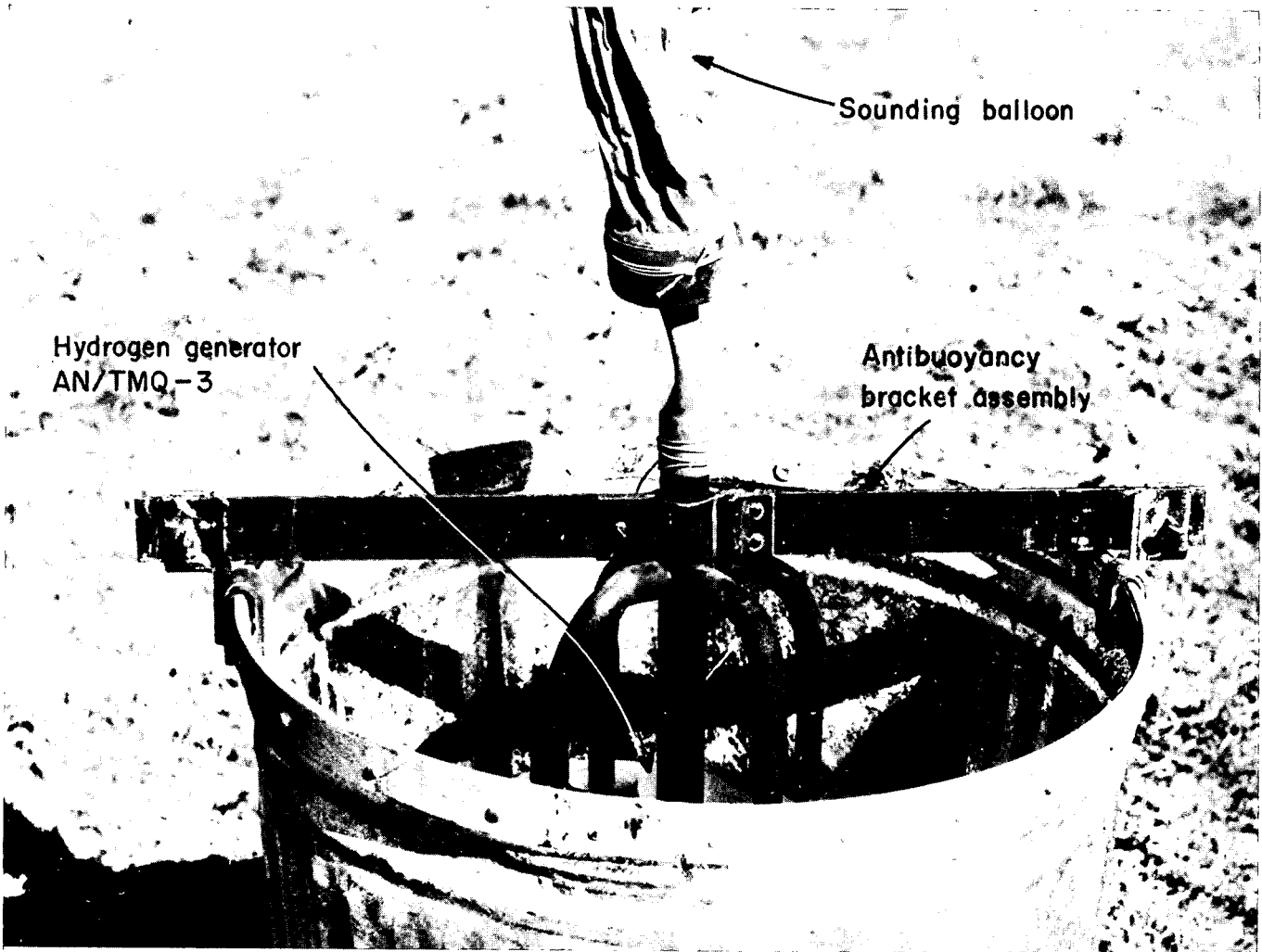

Figure 38. Bracket assembly, antibuoyancy.

and 100-gram pilot balloons. For detailed information, see TM 11-6660-222-12.

(3) *Use.* When high winds prevail, the 100-gram balloon should be used, since it rises faster and will ascend through the desired zones before being blown out of sight. For economy, the 30-gram balloon should be used when the message required is for four lines or less. A general rule in selecting the color of the balloon is the darker the sky, the darker the balloon. For a night flight, the color of the balloon is immaterial.

c. Care and Storage. Balloons should be kept sealed in their original containers until just before use. They should be stored in a dry place and at moderate temperatures. All balloons deteriorate with age; therefore, the oldest balloons should be used first.

63. Inflation Procedure

Conditioning of sounding balloons prior to inflation is necessary to insure maximum bursting altitude.

a. Conditioning of Balloons.

(1) *Purpose.* As a result of exposure to relatively low temperatures and of extended periods in storage, neoprene balloons lose some of their elasticity through the crystallization of the balloon film. Neoprene balloons used in this state will burst prematurely. Therefore, the balloon must be conditioned before inflation to insure maximum elasticity. Conditioning is accomplished by heating the balloon.

(2) *Methods of conditioning.*

(a) Balloons less than a year old need no

conditioning. Usually, exposure of the balloon to room temperature (21° C) for 24 hours is all that is required.

(b) Balloons more than a year old should be conditioned by one of the methods explained in TM 11-6660-222-12. These methods are conditioning with boiling water and conditioning in a locally made conditioning chamber.

(c) Discoloration has no effect on the balloon film, providing the balloon has not been exposed to direct sunlight for several hours. In direct sunlight and in most types of artificial illumination, discoloration is caused by the antioxidant included in the compounding. Antioxidants are used in compounding natural and synthetic rubber to prevent deterioration.

(d) A balloon may be inflated immediately after conditioning, or it may be kept for a year *under normal storage conditions* (para 62c) and then inflated. All balloons should be warmed before inflation.

b. Use of Nozzles and Weights.

(1) *Purpose.* The purpose of nozzle ML-373/GM (fig 39) is to connect hose ML-81 to the *pilot* balloon during inflation, to provide a valve for controlling the flow of gas, and to act as a calibrated weight in determining the correct amount of inflation.

(2) *Description.* The nozzle has two connections at opposite ends—a large connection for the 30-gram pilot balloon and a small connection for the 100-gram balloon. Projecting from the middle of the nozzle is the fitting for hose ML-81. Opposite the hose fitting is a wingnut which controls the valve. The nozzle alone weighs 132 grams, which is the correct free lift weight for a 30-gram pilot balloon inflated with hydrogen for a daytime flight. (Free lift is defined as the net upward force which causes the balloon to rise.) Addition of the main collars which weighs 443 grams, brings the complete nozzle weight to 575 grams, the correct free lift for a 100-gram pilot balloon inflated with hydrogen for a daytime flight. When a night lighting device is attached to the balloon, additional weights are added to the nozzle to compensate for the greater air resistance caused by increased size of the balloon. The additional weights required are 70 grams for the 30-gram pilot balloon and 50 grams for the 100-gram pilot balloon.

(3) *Use.* In using the nozzle, the operator must first install the proper weights, when required, on the neck of the nozzle and stretch the neck of the balloon over the appropriate connec-

tion. In order to expel the air from the balloon and connections to the generator, the operator opens the valve on the nozzle and rolls up the balloon with his hands. He then repositions the valve to allow the hydrogen from the generator to escape into the air, thus clearing the hose and nozzle. The operator then turns the valve so the hydrogen will flow directly into the balloon. During the weighing-off procedure, the valve is used to control the flow of gas. The balloon is weighed off properly when it will hang suspended in mid-air with appropriate weights attached.

(4) *Care and maintenance.* The operator must keep the nozzle free of dirt, lime, or other foreign matter which will alter its weight or obstruct the gas passages. If the valve becomes sticky it should be disassembled, cleaned, and lubricated with graphite.

64. Hydrogen Regulator ML-193

a. Purpose. Hydrogen regulator ML-193 (fig 34) or regulator, pressure, compressed gas ML-528/GM is used with commercial hydrogen or helium cylinders to control the pressure of the gas being released for inflation of a balloon. The regulator also indicates the amount of gas remaining in the cylinder.

b. Description. Hydrogen regulators consist of a regulator valve, which controls the pressure of the gas being released from the cylinder, and two gages. One gage indicates the pressure of the gas being released from the cylinder. The other gage indicates the volume and pressure of the gas remaining in the cylinder. The regulator also has two connections. Hose ML-81 is attached to one connection by use of coupling ML-49. The other connection is attached to the commercial gas cylinder (fig 34).

c. Use. Coupling ML-49 is connected to the gas outlet nipple on hydrogen regulator ML-193, and the connection is tightened with a wrench. The cylinder valve is quickly opened and closed to expel any dirt in the valve opening. The female connection of the hydrogen regulator is attached to the male connection of the commercial gas cylinder tightened with a wrench. (The connections of coupling ML-49, hydrogen regulator ML-193, and the gas cylinder have left-hand threads. Outlet nipples on helium and hydrogen cylinders are different and a pipe nipple is required for coupling the regulator ML-193 when helium is used.) The small end of coupling ML-49 is inserted into one end of hose ML-81. A hose clamp, cord, or wire is used to secure the hose to

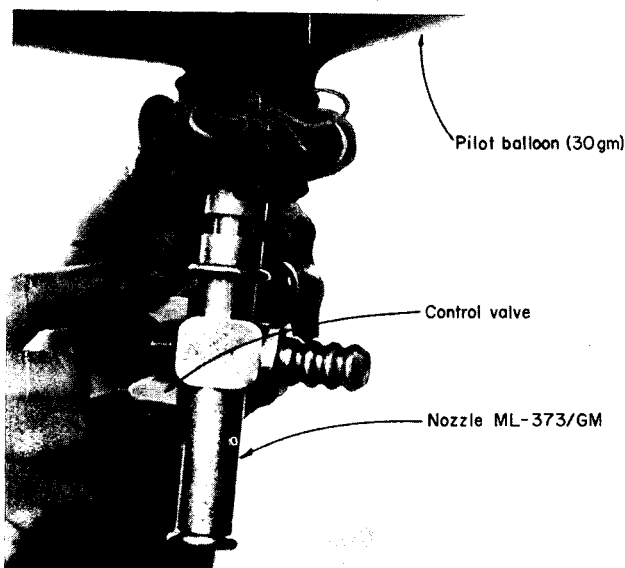

Figure 39. Nozzle ML-373/GM.

the coupling. The free end of hose ML-81 is attached to nozzle ML-196. The gas regulator valve on the hydrogen regulator ML-193 is turned counterclockwise to the locked (off) position. The cylinder valve is opened by turning it counterclockwise. The regulator valve is opened by turning it clockwise to the desired position. The balloon is weighed off as described in paragraph 63b.

65. Night Lighting Units for Pilot Balloons

a. *Purpose.* The purpose of lighting unit ML-338/AM (fig 40) is to provide a light source which will allow the tracking of pilot balloons at night.

b. *Description.* Lighting unit ML-338/AM consists of a 6-volt, water activated battery and a 6-volt bayonet base bulb. A miniature parachute (ML-430/U) and a ball of waxed twine are issued for use with the lighting unit. The parachute need not be used when it is evident that the falling battery will not be a hazard to personnel or property. For detailed information see TM 11-6660-222-12.

c. *Use.* The lighting unit is activated by removing the battery from its insulating jacket and immersing it, with the bulb installed, in water. Any type of water may be used. The battery should remain in the water for about 3 minutes, or until the bulb has reached full brilliance. The lighting device with accessories plus appropriate weights are attached to the nozzle for weighing off the

pilot balloon. The weights for the 30-gram balloon consist of the nozzle, and a 70-gram weight. The weights for the 100-gram balloon consist of the nozzle, a 443-gram and a 50-gram weight. An additional weight is required to compensate for the greater air resistance caused by the increased size of the balloon. The larger additional weight is required for the 30-gram balloon because its size is increased proportionately more than that of the 100-gram balloon when the lighting device has been attached for weighing off.

66. Determination of Inflation Volume and Lift for Sounding Balloons

a. *General.* Free lift is the net upward force which causes the balloon train to rise. The amount of gas required for a sounding balloon should be determined before beginning the inflation process. The ascent rate of the balloon is primarily dependent on the amount of gas. Other factors which affect its ascent rate are the balloon's shape, size, physical texture, and the state of the atmosphere through which the balloon travels. These latter factors are quite variable; therefore, considerable reliance must be placed on experience to obtain an ascent rate which will allow the flight to attain required height at least 15 minutes prior to prescribed message time. Table 1 is included for use in determining the amount of free lift for sounding balloons during fair weather. It is important for the gas temperature to be equal to the ambient air temperature. This condition is facilitated by use of a condenser with the generator AN/TMO-3 or by valving gas slowly (up to 20 minutes) when using commercial gas.

Table 1. Free Lift Table

Balloon type	Use	Free Lift (grams)
ML-159A/UM	Day	600
ML-159A/UM	Night	800
ML-537 ()/UM	Day	1600
ML-537 ()/UM	Night	1900
ML-541 ()/UM	Day	2500
ML-541 ()/UM	Night	2700

b. *Computation of Required Total Lift.* Total lift is defined as the weight, in grams, which must be balanced by the inflated balloon in order for the balloon to lift the attachments and assure a desired rate of rise. As a convenient reference, the weights of the usual balloon train attachments are listed in table 2. Table 3 indicates additional weights necessary to compensate for adverse weather conditions.

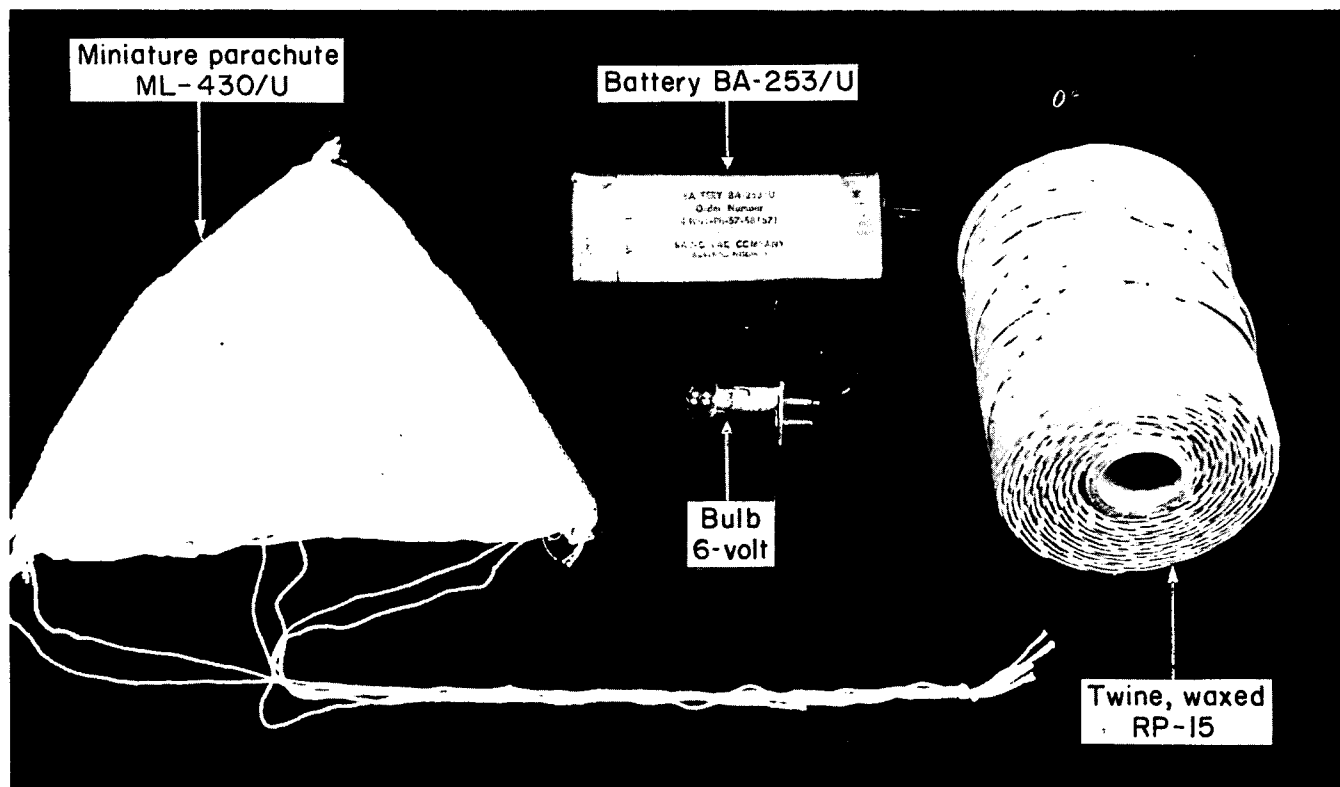

Figure 40. Lighting unit ML-338/AM, with accessories.

Table 2. Weights of Balloon Attachments

Attachment	Weight (grams)
Radiosonde AN/AMT-4 (), with battery	1105
Lighting unit ML-338	85
Parachute ML-132	150

Table 3. Additional Weights for Foul Weather.

Weather	Weight (grams)
Precipitation of light intensity (all balloon types)	200
Heavy precipitation and/or icing (all balloon types)	400
Average zonal wind exceeding 60 knots (spherical balloons)	600 to 1200

Example: An example of the computation of the total lift required for a typical daytime radiosonde flight using balloon type ML-537/UM is as follows:

Required free lift, from table 1	1600 grams
Weight (radiosonde and parachute) from table 2	1255 grams
Total lift required (highest 100 grams)	2900 grams

(1) The computed total lift (2900 grams) is used to enter the nomograph in TM 11-6660-245-15 to determine the volume of gas required to inflate the balloon. The plate on the hydrogen-helium meter can be used as a guide to determine the required volume of gas for the various types sounding balloons. However, this guide is only a rough estimate which does not compensate for additional weight required for foul weather or night flights.

(2) If calcium hydride is used for inflation, then the number of charges necessary to produce the required amount of gas must be determined. The amount of gas produced by each type of calcium hydride charge is as follows: ML-587/TM-42 cubic feet, ML-305A/TM-24 cubic feet, and ML-304A/TM-6 cubic feet.

67. Preparation of Balloon Trains

When the balloon is properly inflated, it is sealed and tied. A 20-meter length of twine is doubled (i. e., 10-meter length, double strength) and the neck of the balloon is sealed and tied with the open end of the twine (fig 41). Next, parachute ML-132 is secured to the closed end of the dou-

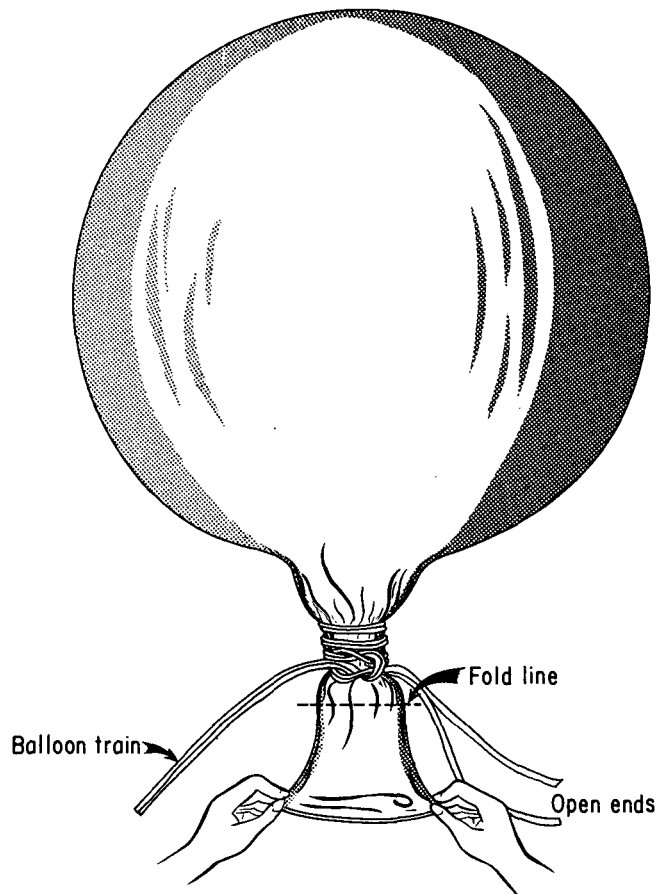

Figure 41. Tying off the balloon.

bled twine. Another 20-meter length of twine is doubled, the open end is secured to the bottom of the parachute suspension lines, and the radiosonde is tied to the closed end. The overall length of the train is approximately 20 meters (fig 42). The parachute is not normally used in an active theater of operations. The purpose of the 20-

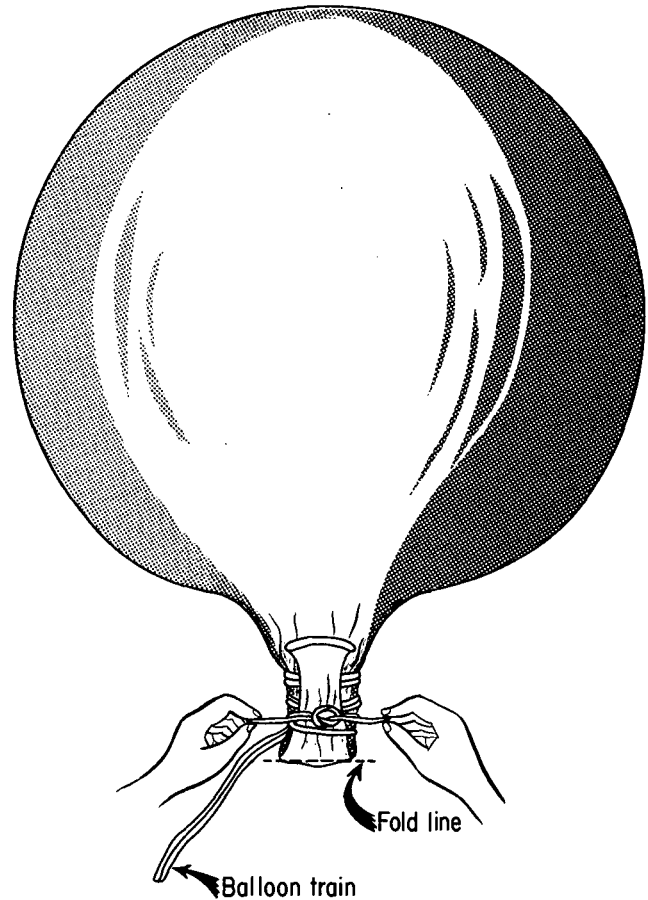

Figure 41—Continued.

meter balloon train is to dampen the oscillation of the radiosonde during flight. Night lighting device ML-338/AM may be included in the train between the parachute and the radiosonde to aid in initial tracking.

Section IV. PLOTTING AND COMMUNICATIONS EQUIPMENT

68. Wind Plotting Equipment

a. Purpose. The purpose of the wind plotting equipment (fig 22) in meteorological station, manual AN/TMQ-4 is to provide a means of determining the zone and ballistic winds.

b. Description. The wind plotting equipment includes two plotting boards ML-122. Two rules ML-126A are issued with each plotting board (each board has a spare rule). The plotting equipment also includes two scales ML-577 and one slide rule. Plotting board ML-122 and rule ML-126A are used to plot the flight path of the

balloon as projected on the curved earth. These plots are made with rule ML-126A at a scale of 1 inch equals 750 meters. Zone wind speeds are computed from the measured distance between plots with rule ML-126A. These distances are measured in meters. A slide rule is used to determine the wind speed in knots. The zone wind directions are measured by using scale ML-577. Scale ML-577 is also used in plotting the ballistic winds on plotting board ML-122. Use of this scale permits reading the wind direction to the nearest 10 mils.

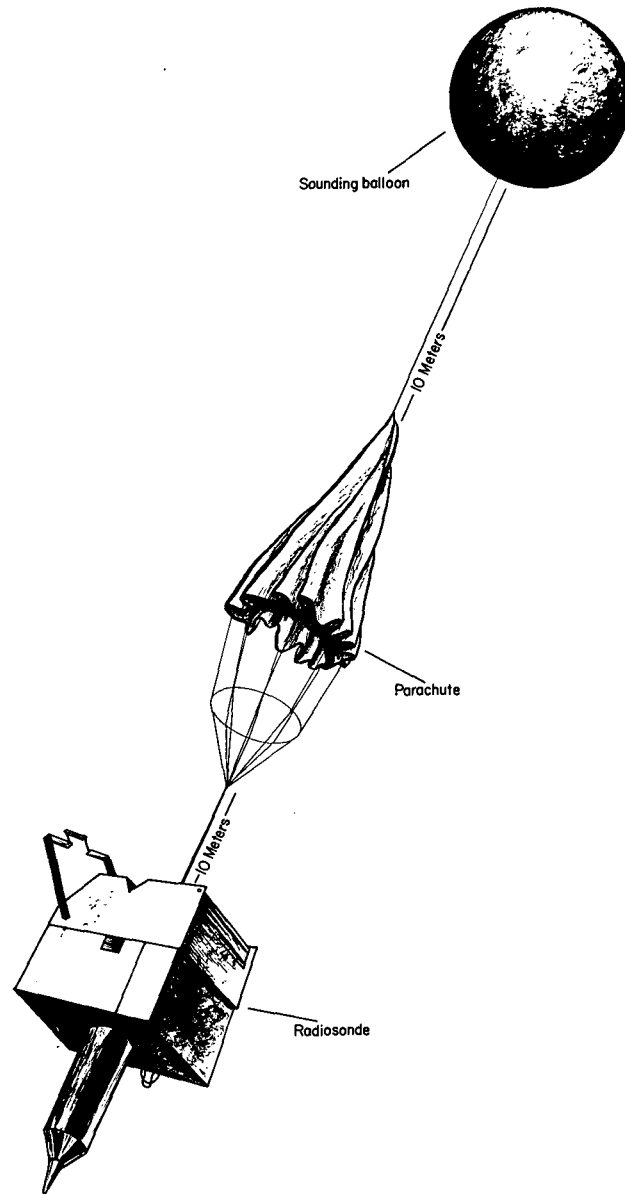

Figure 42. The balloon and train.

c. *Use.* Plotting is done with a medium hard pencil (3H) to avoid pitting the plastic surface of the plotting board. After use, the plots are erased with an ordinary eraser. Detailed instructions on the use of wind plotting equipment in determining the zone and ballistic winds are contained in chapter 10.

d. *Preventive Maintenance.* After considerable use, the plotting boards become smudged and should be washed with soap and water. Plotting equipment should never be cleaned with cleaning solvents or oils. Scale ML-577 should be wrapped in cloth to prevent fogging and scratching of the

graduated surfaces. The slide rule may be dusted with talcum powder to reduce sticking. If the cursor glass on the slide rule is removed for cleaning, it should be remounted with care to insure that the crosshair is in alignment with the scales.

69. Communication Equipment

a. Wire.

(1) *Purpose.* The purpose of the wire communication equipment (fig 31) is to provide the theodolite operator a means of reporting the angular data to the timer recorder. The met section

also has one field telephone for wire communication to a headquarters switchboard.

(2) *Description.* The communication equipment consists of two head and chest sets HS-25-C, one telephone set TA-312/PT, one reel RL-39() with spool DR-8 and 400 meters of wire WD-1/TT, two jacks JK-54, and one headset H-144/U. The head and chest sets (H-25-C) are sound-powered; that is, the transmitter in each set generates a small electric current when activated by sound waves. With good connections, head and chest sets may be operated successfully over a distance of several kilometers. Jacks JK-54 facilitate connection between the wire and the output cords of the chest sets.

(3) *Use.* When the wire is installed, it is tied to some fixed object near the terminal so that accidental tripping over the wire will not destroy the connection.

Caution: Do not tie the wire to the theodolite tripod.

(4) *Preventive maintenance.* The reel bearings should be oiled occasionally with heavy oil. The wire should be inspected frequently for wear and repaired or replaced where necessary. The connections should be kept clean and tight at all times.

Section V. RAWINSONDE SYSTEM

70. General

The rawinsonde system was designed for taking atmospheric soundings and thereby obtaining upper air meteorological data. This is accomplished by measuring the wind speed, wind direction, pressure, temperature, and humidity throughout the vertical extent of the sounding. Since the upper air meteorological variables are actually measured, data obtained from this system are more accurate than data provided by the visual technique.

71. Equipment

a. Equipment of the Rawinsonde System. The rawinsonde system consists of the following major items of equipment (fig 43):

- (1) Radiosonde AN/AMT-4().
- (2) Rawin set AN/GMD-1().
- (3) Radiosonde recorder AN/TMQ-5().

b. Associated Equipment. The following associated equipment is also used with the rawinsonde system:

- (1) Frequency standard TS-65() TMQ-1.

b. Radio Set.

(1) *General.* The met sections are equipped with AM (RATT) radio sets. The AM (RATT) radio set allows rapid dissemination of meteorological data and coordination of the meteorological activity throughout the crops sector.

(2) *Use.* The location for equipment depends on the tactical situation and on local conditions, such as the need for camouflage, the type of vehicle in which the equipment is mounted, possible installation in a shelter, and the terrain. The radio set will have a greater distance range if the antenna is high and clear of hills, buildings, cliffs, and wooded areas. Valleys and other low places are poor locations for radio reception and transmission, because the surrounding high terrain absorbs the radio frequency (RF) energy. Clear, strong signals cannot be expected if the radio set is operated near steel bridges, underpasses, power lines, hospitals, or power units. If possible, a site on a hilltop or other high place should be chosen. Generally, transmission and reception are better over water than over land. Detailed procedure for operation and preventive maintenance of radio sets is discussed in the appropriate TM 11-series.

- (2) Baseline check set AN/GMM-1().

- (3) Test set TS-538/U.

- (4) Power unit, 10-Kw; and/or power unit PE-75-().

- (5) Meteorological station, manual AN/TMQ-4.

c. Capabilities and Limitations of the Rawinsonde System. The rawinsonde system provides an all-weather capability of obtaining atmospheric soundings to altitudes in excess of 30,000 meters. The system affords a means of determining meteorological data within this region of the atmosphere to a high degree of accuracy. One major limitation of the present rawinsonde system is the relatively long time required to complete a sounding, which is due primarily to the slow rate of rise of the balloon. Various methods of decreasing the time required for a sounding are being tested in the field. At extreme altitudes, there is a decrease in the accuracy of the pressure values obtained with current radiosonde equipment. This problem may be reduced through the use of the hypsometer (para 74). The elec-

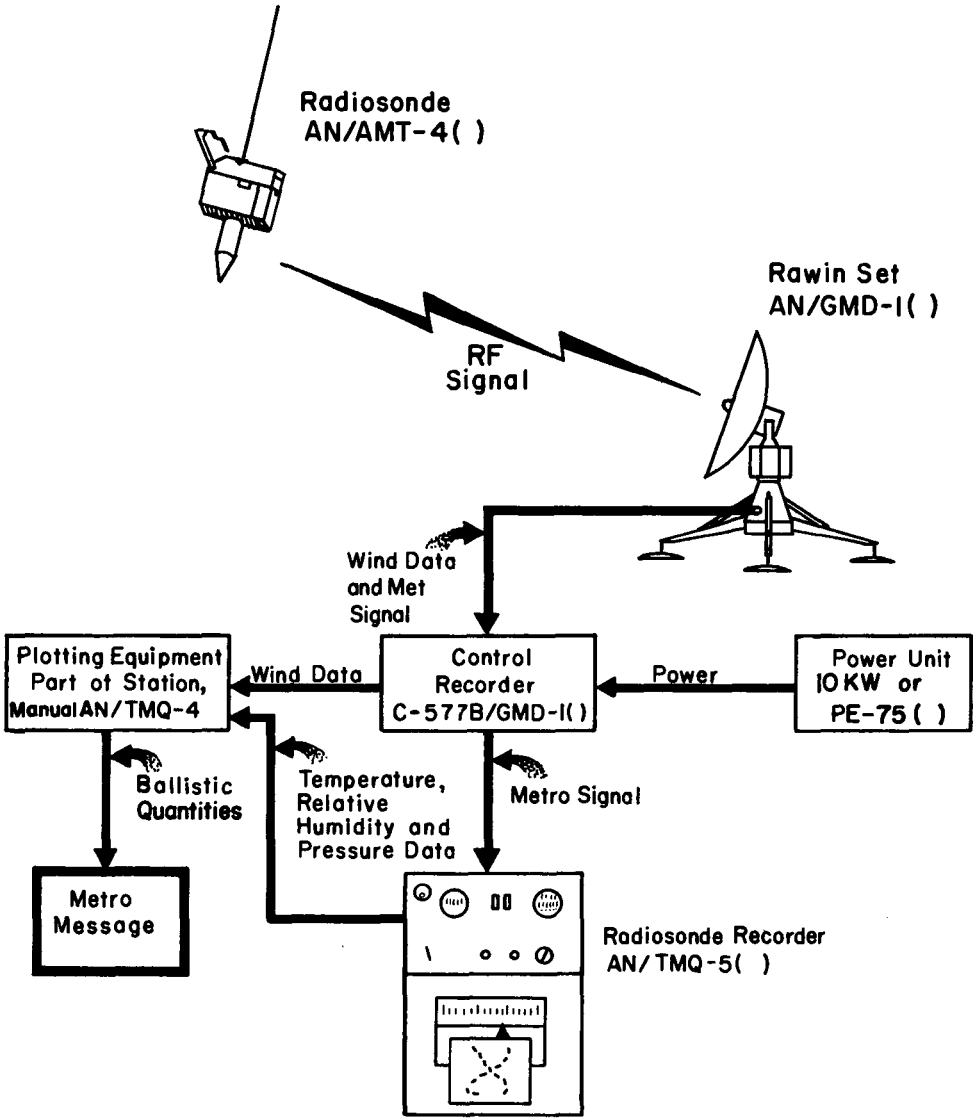

Figure 43. Equipment of the rawinsonde system.

tronic equipment of the rawinsonde system is also subject to failure. Specially trained personnel are

required to operate the equipment and perform the necessary maintenance.

Section VI. RADIOSONDES

72. General

Several models of the radiosonde are in use. All models are similar in appearance and operation. The model used by U.S. Army meteorological sections is the AN/AMT-4(). For detailed information concerning the differences in radiosondes, see TM 11-2432A.

73. Radiosonde AN/AMT-4()

a. Purpose. The purpose of radiosonde AN/AMT-4() (fig 44) is to provide a means of measuring the atmospheric pressure, temperature, and humidity to altitudes in excess of 30,000 meters.

b. Description and Operation.

(1) *Description.* Radiosonde AN/AMT-4() is a balloon-borne, battery-powered, meteorological instrument which automatically transmits pressure, temperature, and humidity information to a ground receiving station by means of radio waves. The radiosonde consists of a modulator and a transmitter. The modulator (fig 45) is assembled in a white plastic container. The top of the container may be opened to permit access to the baroswitch mechanism. Temperature element clips are mounted on support arms attached to the sides of the modulator top. Humidity element clips are under a small removable lid on the top of the modulator. A hinged door on the bottom of the modulator provides access to the battery compartment. Clips on the outside of this door secure the transmitter to the modulator. The transmitter is enclosed in a plastic tube. One end of the tube is pointed, and the other end is closed by a removable cover and rubber gasket. The leads used to interconnect the transmitter and the modulator are in either one or two plugs, depending on the model of the transmitter. The pressure unit is the heart of the modulator, since it activates all of the electrical weather-measuring circuits. It consists of one or two aneroid pressure cells, which expand as the atmospheric pressure decreases. By means of a linkage and lever system, this small expansion moves a thin pin arm across a bakelite plastic bar, the commutator bar, which is marked with 150 metal strips. The metal strips on the commutator bar conduct electricity; the bakelite material which separates these strips is a nonconductor. The end of the commutator bar is fitted with an adjusting screw so that the commutator bar may be moved laterally with respect to the pin arm. The pin arm

may be raised from contact with the commutator bar by means of a lifting lever. An electrical relay acts as a switching device for the temperature and humidity circuits. A radiosonde test plug or (in later models) three test leads are available for testing the electrical circuits and connecting the modulator to the baseline check set AN/GMM-1(). The transmitter of the radiosonde is housed in a cylindrical plastic container. The transmitter consists of two subminiature electron tubes and the necessary circuit components to produce an ultrahigh-frequency (UHF) radio signal of 1680 megahertz (MHz). This frequency setting may be manually adjusted plus or minus 20 megahertz.

Note. A restriction has been placed on the use of radio frequencies in the 1660-1670 MHz band within CONUS for meteorological radiosonde observation. The Department of the Army, Office of the Chief of Communications-Electronics, ATTN: CCEFMM, Washington, D. C. 20315 will be notified in advance, as early as possible, of all use of the band (1660-1670 MHz) for radiosonde operation.

The temperature element is a small ceramic resistor which is coated with a white lead carbonate pigment to reflect the sun's rays. The electrical resistance of this element changes as the ambient temperature changes. Its range of measurement is from +60° to -90° Celsius. The temperature element is placed between the clips of two support arms. The humidity element is a strip of polystyrene plastic, fitted with two metal electrodes along the long edges and coated with a moisture sensitive film. The electrical resistance of the humidity element varies with both humidity and temperature. Its range of measurement is from 10 to 100 percent relative humidity. The humidity element is mounted between the clips on the top of the modulator. The temperature and humidity elements and a pressure unit calibration chart are packed in a cardboard box and stored in the battery compartment. The pressure unit calibration chart shows the relationship between the position of the pin arm on the commutator bar and the air pressure. This calibration chart is furnished by the manufacturer.

(2) Operation.

(a) General. As the aneroid pressure cell(s) expands, the pin arm of the modulator moves across the commutator bar and contacts, in turn, each of the 150 metal strips (fig 46). Each silver strip (conducting segment) and the follow-

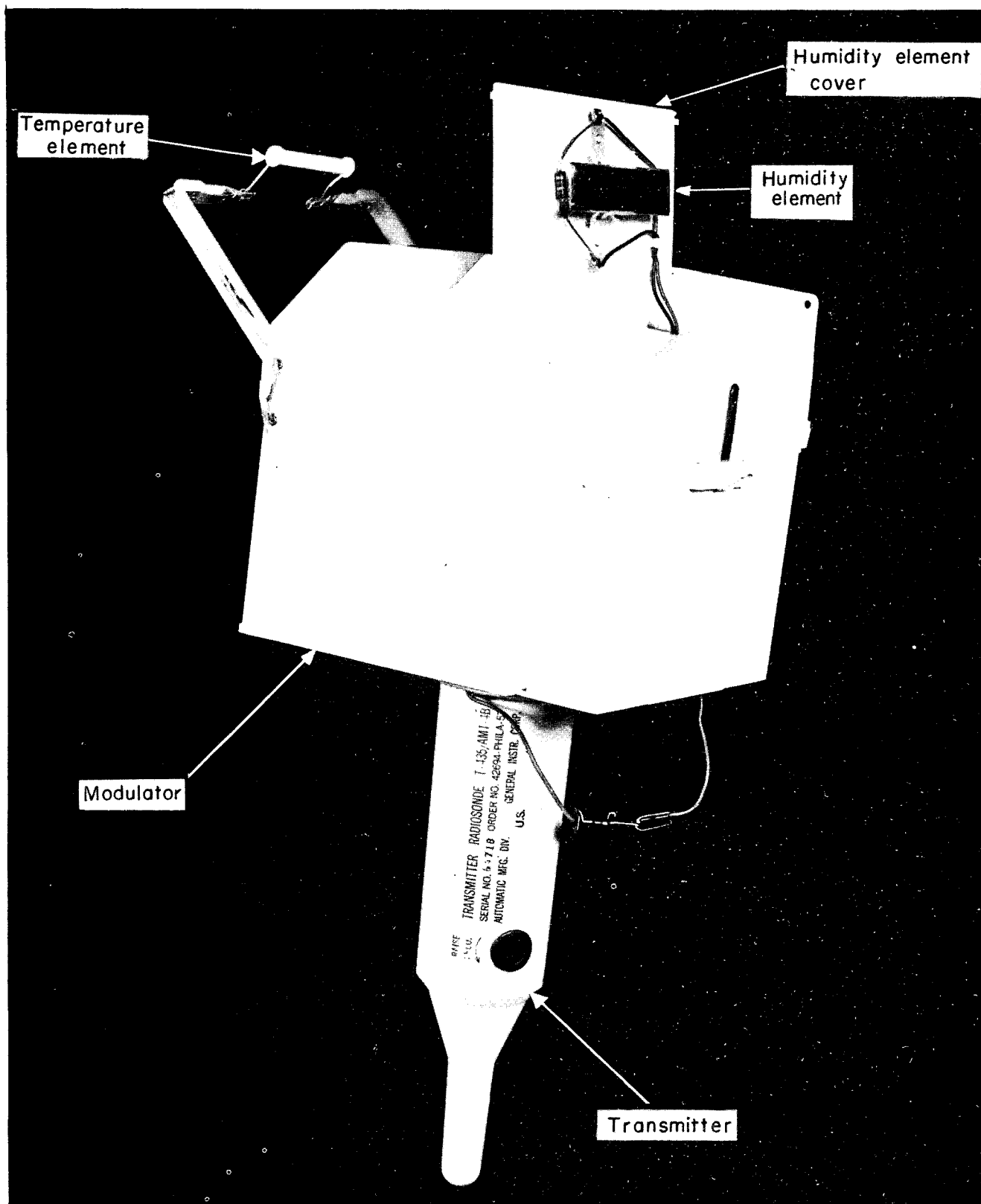

Figure 44. Radiosonde AN/AMT-4().

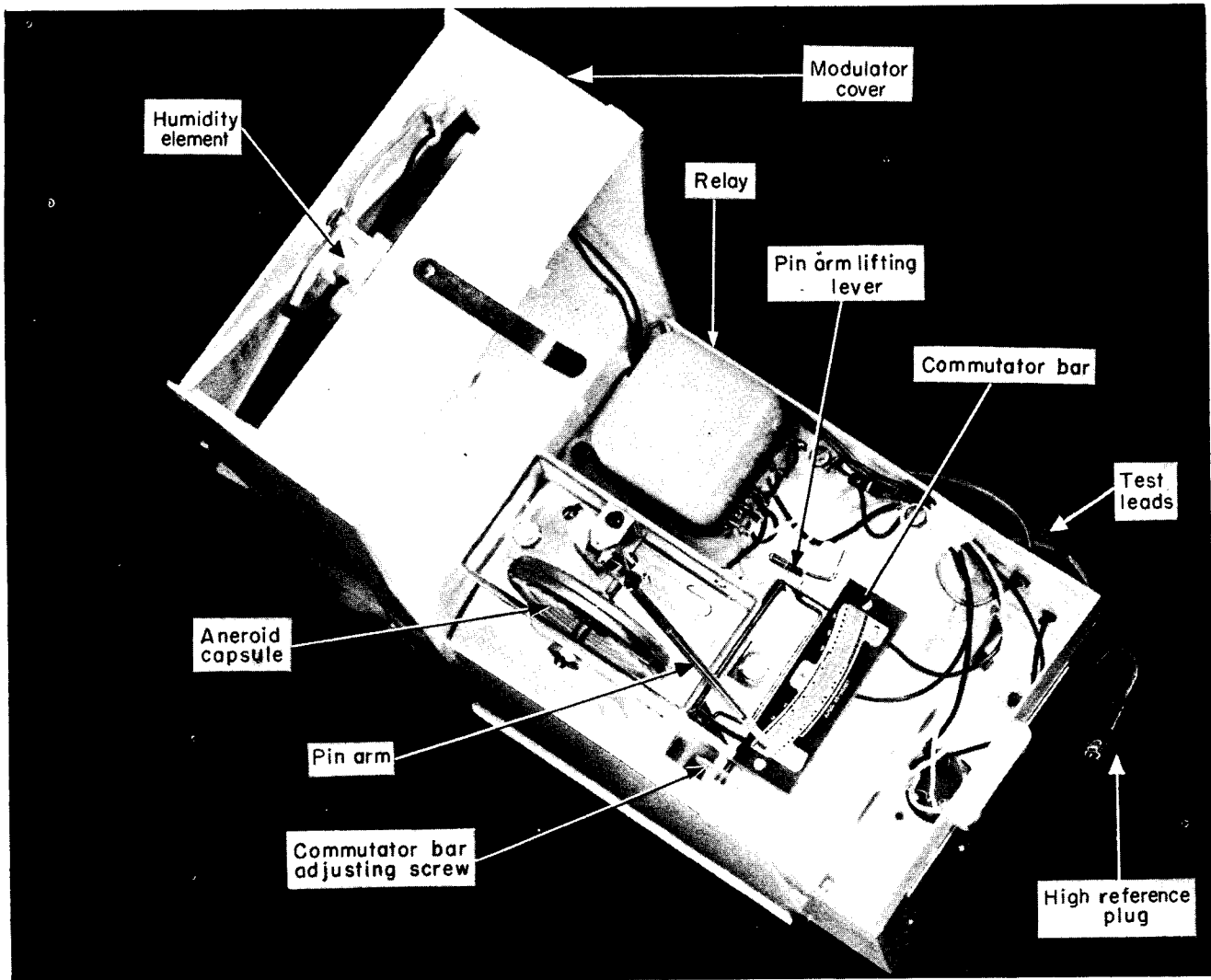

Figure 45. Radiosonde modulator MD-210/AMT-4B.

ing bakelite strip (insulating segment) compose one contact of the commutator bar. Thus, the commutator bar is composed of 150 contacts in all. The temperature and humidity sensing elements are connected into the transmitter circuit at various positions of the pin arm along the bar. The electrical current conducted by the sensing elements operates the blocking oscillator tube of the transmitter. This electrical current causes the tube to turn itself off and on at an audio rate between 8 and 194 hertz (Hz), depending on the particular value of resistance in the circuit. The amount of this resistance is determined by the position of the pin arm on the commutator bar and the existing weather values. The blocking oscillator tube affects the carrier wave transmitter tube so that the 1680 MHz carrier wave is modu-

lated at a rate dependent on existing weather values. Ground based equipment demodulates the wave and records the measured weather values on a printed chart for evaluation.

(b) *Arrangement of the commutator bar.* There are four circuits which may be switched into the transmitting circuit by the movement of the pin arm over the 150 contacts on the commutator bar. The contacts are numbered from 1 to 150, beginning with the high pressure end. Starting with 1, the conducting segment of every fifth contact up to the 105th contact, except multiples of 15, connects the low reference circuit and causes the radiosonde to transmit a signal which is modulated at a rate of 190 hertz. Low reference signals are used to identify the contact pattern of the radiosonde data during flight and to

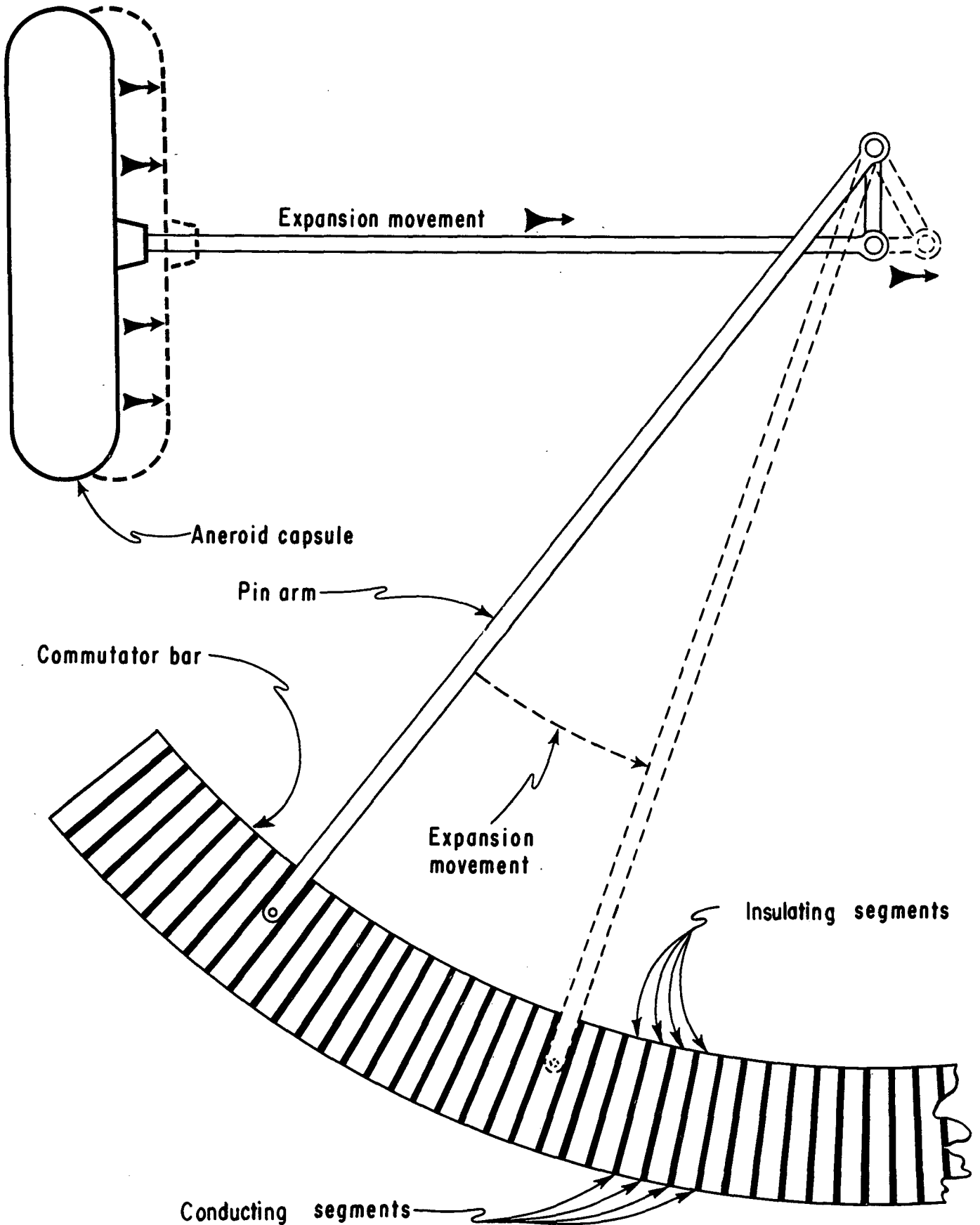

Figure 46. Action of baroswitch.

adjust the temperature and humidity signals. The conducting segment of every 15th contact through the 105th contact connects the high reference circuit and causes the radiosonde to transmit a signal which is modulated at a rate of approximately 194 hertz. High reference signals are also used to identify the radiosonde contact pattern during flight. All other conducting segments up to the 105th contact activate the relative humidity sensing circuit and cause the radiosonde to transmit a signal modulated at a rate of 8 to 185 hertz, depending on the ambient humidity. After the 105th contact, it is no longer necessary to measure the humidity, and each conducting segment that is not a multiple of 5 becomes low reference and each fifth conducting segment becomes high reference. When the pin arm is not on a conducting segment, the temperature sensing circuit is activated and the radiosonde transmits a signal modulated at a rate of 8 to 170 hertz depending on the ambient temperature. The insulating segments between conducting segments are the temperature segments. A guide to the relative constructed width of all segments are shown in table 4. A contact begins at the base of a relative humidity or reference segment and ends at the top of a temperature segment. Because of manufacturer's tolerances and differences in widths of pins, contact values as recorded on the radiosonde record are different from the constructed values. When evaluating a radiosonde record to determine pressure contact value, determine proportional parts of a contact with reference to the whole contact as it appears on the record. For example, the relative humidity portion of a contact is not necessarily 0.3 of the whole contact.

Table 4. A Guide to the Construction of Segments

Trace	Contact value
Humidity segment	0.3
Temperature segment following a humidity segment	0.7
Reference segment	0.4
Temperature segment following a reference segment	0.6
Low reference segment above the 105th contact	0.3

74. Radiosonde Set AN/AMT-12 (Hypsometer)

a. *General.* As stated in paragraph 71c, a disadvantage of the current rawinsonde equipment is the decrease in accuracy of the pressure values obtained at higher altitudes. This error can be reduced by the use of a hypsometer instead of an

aneroid cell to measure the pressure at high altitudes. The hypsometer is a comparatively simple device which measures boiling temperature of a liquid (carbon disulfide) (CS₂) to determine pressure. The boiling point (temperature) of carbon disulfide is directly related to the atmospheric pressure. The hypsometer consists of an insulated container, a thermistor, and the liquid carbon disulfide. The hypsometric radiosonde AN/AMT-12 (fig 47) has been developed for higher altitude soundings. This radiosonde can measure pressures down to 2 millibars with an accuracy of about 0.1 millibar. The hypsometric radiosonde is identical in physical appearance to radiosonde AN/AMT-4(). Inside the modulator, however, is a hypsometric boiler. The boiler is a vacuum flask, about the size of a small radio tube; it is open at the top and mounted upright just in front of the commutator bar of the baroswitch. The temperature measuring element inside the flask is fishhook shaped and wrapped in cotton for protection. Just before flight, the small flask, or boiler, is charged with 5 cubic centimeters of carbon disulfide by use of a hypodermic needle and syringe. For further description, see TM 11-6660-220-10.

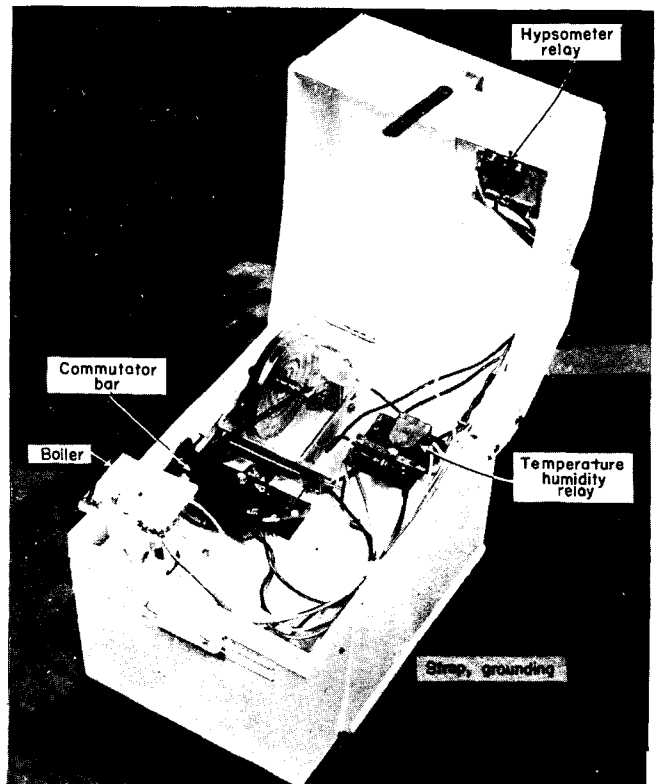

Figure 47. Radiosonde set AN/AMT-12 (hypsometer).

b. Function. After release, radiosonde set AN/AMT-12 functions in exactly the same manner as radiosonde AN/AMT-4() until it reaches an altitude corresponding to the 105th contact. At contact 106 and alternately every third and second contact thereafter (i.e., 106, 109, 111, 114, 116, etc), the hypsometric circuit is activated. The temperature element measures the temperature of the boiling carbon disulfide. By using a special calibration chart, the met section converts the hypsometric temperature ordinate value to a pressure reading. At pressures of approximately 40 millibars and lower, the hypsometric pressure is

used in place of the aneroid pressure. (See chapter 7 for details.)

Warning: Carbon disulfide is noxious and flammable and should be handled with care.

c. Frequency Adjustment. The frequency of the carrier wave of radiosonde set AN/AMT-12 is adjustable over a range of 1660 to 1700 MHz by means of adjusting screws on the transmitter. Test set TS-538/U is used to adjust the frequency. Procedure for adjusting the frequency is the same as for radiosonde AN/AMT-4() and is discussed in chapter 7.

Section VII. RAWIN SET AN/GMD-1()

75. General

The purpose of rawin set AN/GMD-1() (fig 48) is to provide a means of tracking a balloon-borne radiosonde transmitter throughout its flight, measuring elevation and azimuth angles to the radiosonde, and receiving radio signals from which values of temperature, pressure, and relative humidity may be determined.

76. Description

The rawin set AN/GMD-1 is a transportable radio direction finder. The set consists of a main assembly, a control-recorder, and a trailer adapter kit. The main assembly consists of an antenna scanner assembly, the antenna control, a receiver, and a pedestal. The main assembly automatically tracks the radiosonde during flight. The azimuth and elevation angles to the radiosonde are measured, along with the time since release, and recorded on a paper tape. The receiver of the set is manually tunable over a frequency range of 1660 to 1700 megahertz and automatically tunes itself after it is locked on a particular radiosonde signal. The radiosonde transmission signal which provides weather intelligence is demodulated by the receiver and sent to the radiosonde recorder AN/TMQ-5() (not a component of the rawin set). The control-recorder, a combination remote control and recording device for the main assembly, is connected to the main assembly by a cable approximately 62 meters long. The control-recorder also serves as a junction box for power distribution; it receives 105 to 129 volts of alternating current, 50 to 65 hertz from the power source and relays it through cables to the main assembly and the radiosonde recorder. The rawin set will automatically track the radiosonde to altitudes in excess of 30,000 meters and

to horizontal distances in excess of 200 kilometers, depending on the surrounding terrain. The set has four automatic features as follows:

a. Receiving and demodulating the radiosonde weather signal.

b. Tuning the receiver to receive the transmitted signal.

c. Tracking the radiosonde throughout the flight.

d. Recording angular data to the radiosonde during tracking.

77. Employment

a. Selection of Site. The ideal site for the operation of the rawin set is the center of a large plateau, with no natural or artificial objects within 200 meters and no obstructions, at any distance, extending 3° above the horizon. However, ideal conditions seldom exist and the selection of an operating site must often be a compromise. Several of the major considerations for siting the rawin set are listed below.

(1) The distance from the operating location of the control-recorder to the main assembly must not exceed 60 meters to allow for slack in the main cable.

(2) The horizon from the main assembly should be unobstructed above 3° (at least in the direction toward which the balloon-borne radiosonde is carried by the prevailing winds). The prevailing winds, when known, must be considered.

(3) The main assembly must be installed on a level and firm site so that accurate leveling and orientation may be obtained.

(4) An adequate, clear area must be available for the release of the balloons; the release position should be downwind from the rawin set

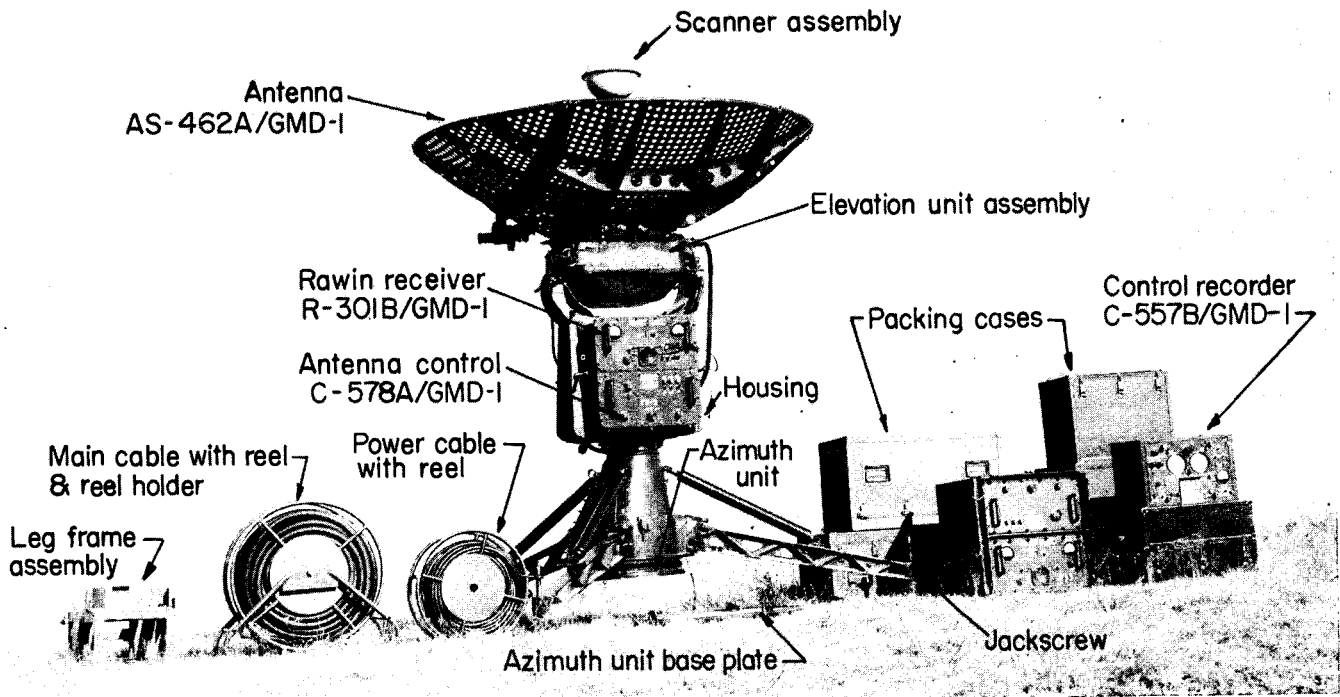

Figure 48. Rawin set AN/GMD-1().

main assembly (100 meters when possible) and adjacent to the balloon inflation shelter.

(5) Nearby structures and elevated terrain must be avoided, since they may reflect the radio signal from the transmitter and give erroneous angular data.

(6) Distant landmarks, suitable for orientation, should be visible from the site.

(7) The operating site should be conveniently accessible to operating personnel.

b. Leveling. Leveling of the rawin set (fig 49) is performed during the initial installation.

(1) The main assembly of the AN/GMD-1() must be leveled as accurately as possible in order to prevent errors in elevation angle readings as the antenna rotates in azimuth. Small errors in elevation angles can cause large errors in the determination of zone wind speeds. The main assembly should be leveled when installed and checked prior to each flight to compensate for possible settling of the jack plates. Leveling should be verified after each flight, especially when flights are conducted during or following periods of precipitation. Two spirit levels, placed at right angles to each other, are mounted on the right side of the housing. In rawin set AN/GMD-1B, a third spirit level is mounted in the base of the elevation yoke. This

level is provided for future use with ranging equipment. Each level is equipped with a tubular cover that can be rotated to cover the glass portion of the level when it is not in use. For minimum error and maximum stability, as much of the jackscrews is kept above the legs as is practicable.

(2) The procedure outlined below should be used in leveling any AN/GMD-1 (fig 49) which contains two intact leveling bubbles.

(a) The antenna is raised to the 90° (vertical) position.

(b) The turntable is rotated manually or electrically until the azimuth stow lock is over the recess in the azimuth unit. This position aligns level 1 with a line connecting jacks A and B and aligns level 2 with leg C.

(c) Leg A and/or B is raised or lowered to center the bubble in level 1.

(d) Leg C is raised or lowered to center the bubble in level 2.

(e) The turntable is rotated 180°. If the bubbles are in the center position, leveling is completed with step (h) below. If the bubbles are not centered, half of the error indicated by the position of the bubbles should be corrected by adjustment of the appropriate jack(s). (This error results from leveling bubbles which are not

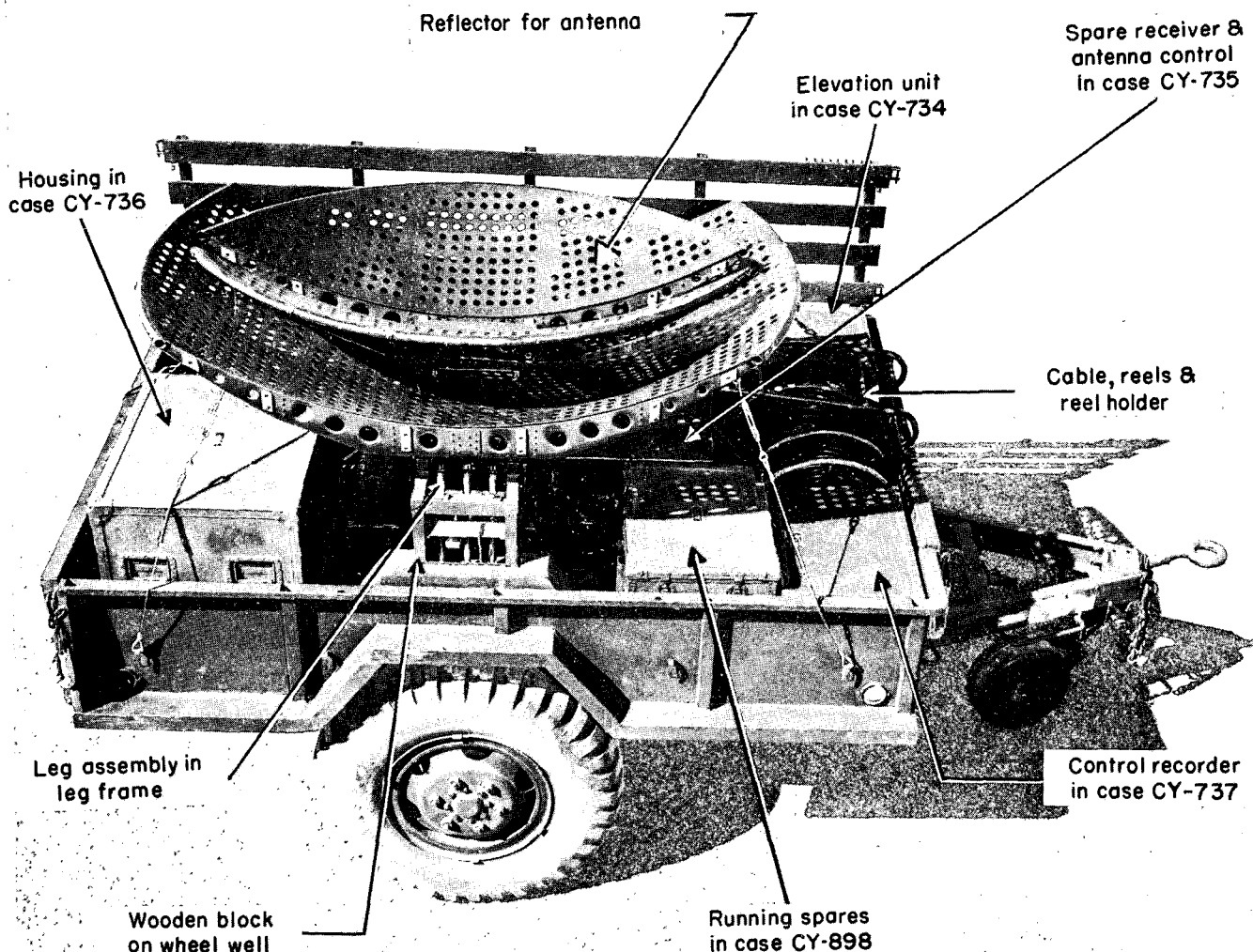

Figure 48—Continued.

mounted on a plane parallel to the frame of the radio direction finder housing.)

(f) The turntable is rotated 180° back to the starting position. In this position, the bubbles should indicate the same error as the error at 180° (after correction). If these two errors are not equal, the leveling procedure is repeated, using steps (b) through (f), until they are equal.

(g) The turntable is *slowly* rotated through 360° of azimuth, and the bubbles are observed. If the AN/GMD-1() is level, the bubbles will remain close to the center position. If the bubbles move from one side of the center of the level to the other side, the set is releveled following steps (b) through (g).

(h) All leg-locking lugs are tightened.

(3) The procedure outlined in (a) through (k) below will level the AN/GMD-1() (fig 49) when only one of the two bubbles is intact. This method is very similar to the procedure given in (2) above but requires more time, since special

care must be taken to correctly align the bubble with the desired portion of the radio direction finder.

(a) The antenna is raised to the 90° (vertical) position.

(b) The level is carefully aligned with a line connecting jacks A and B.

(c) Leg A and/or B is raised or lowered to center the bubble in the level.

(d) The turntable is rotated exactly 180° . If the bubble is centered, leveling is continued with step (g) below. If the bubble is not centered, half of the error indicated by the position of the bubble should be corrected by adjustment of the appropriate jack.

(e) The turntable is rotated 180° back to the starting position. In this position, the bubble should indicate the same error as the error at 180° (after correction).

(f) If these two errors are not equal, the leveling procedure is repeated from (b) through

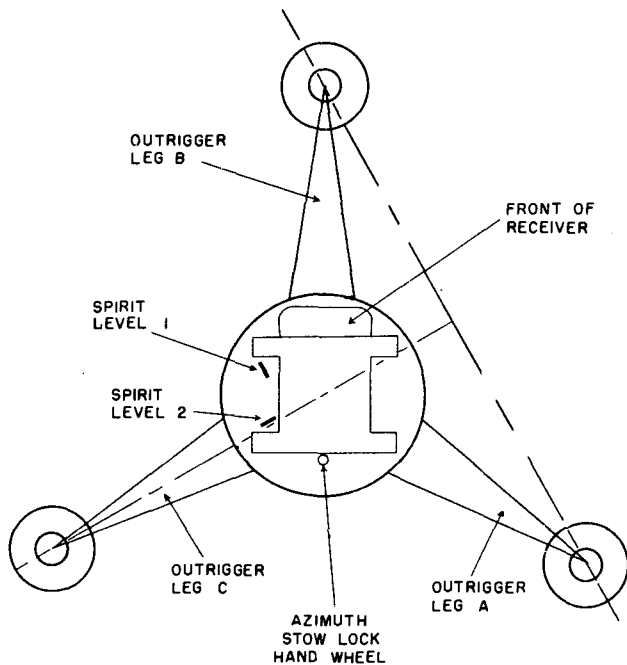

Figure 49. Leveling the rawin set AN/GMD-1().

(e) until they are equal.

(g) Next, the level is carefully aligned with leg C.

(h) Leg C is raised or lowered to center the bubble in the level.

(i) The turntable is rotated exactly 180° . If the bubble is centered, leveling is continued with (j) below. If the bubble is not centered, the errors at the original position and the 180° position are equalized as in (d), (e) and (f) above.

(j) The turntable is slowly rotated through 360° of azimuth, and the bubble is observed. Of the AN/GMD-1() is level, the bubble will remain close to the center position. If the bubble moves from one side of the center of the level to the other side, the set is releveled following steps (b) through (i) above.

(k) All leg-locking lugs are tightened.

c. Orientation. Until all angle-indicating dials and the recording mechanism of the control-recorder have been properly oriented, any angular data will be incorrect. Thus, the orientation of the rawin set becomes very important in the computation of accurate wind data. Orientation should be performed during initial installation of the rawin set and checked before and after each flight. Listed below are the two most common methods of orienting the rawin set.

(1) Survey control will generally be available for orientation purposes in the area where the met section is located. The coordinates and alti-

tude to the nearest 10 meters of the selected position and the angular data, grid azimuth, to reference points can be provided by unit survey personnel. Stationary objects, such as a pole, building, or tower should be selected as reference points. These objects should be at a considerable distance, never less than one kilometer, from the rawin site. Survey data to reference points are converted to true north by use of chart III, FM 6-16.

(2) When survey data are not provided, the orientation of the rawin set will be accomplished by use of the theodolite. The theodolite is set up, centered, and leveled over the selected site (usually shown by a stake or other suitable marker) of the main assembly. The declination constant, true north, for the area of operation should be set on the azimuth scale before the theodolite is oriented utilizing the magnetic needle. The elevation and azimuth angles are then measured by sighting the theodolite on a well-defined portion of the object used as a reference point. These angles are read to the nearest one-tenth degree and recorded for future reference.

(3) The main assembly should be centered over the point on the ground which was used to determine orientation data. After the rawin set is completely assembled, leveled, and energized, the manual controls are used in sighting the GMD telescope on the reference point. When the telescope is on the point, the motors are turned to the STANDBY position to prevent vibration during the orientation process. The local angle indicators on the azimuth and elevation units are set to the angular values furnished by survey, converted, or from the theodolite measurements. The remote angle indicators and printing mechanism on the control-recorder are set to indicate and record the same angular data that were set on the local angle indicators. This adjustment completes the orientation of the rawin set.

d. March Order. The met section should become proficient in the unloading, assembly, disassembly, and loading of the rawin set so that rapid displacement will be possible. The ability to assemble and disassemble the rawin set quickly and properly may mean the difference between timely or late delivery of the met message to the using units. Damage due to improper procedure may cause a loss of valuable time while waiting for the maintenance technician to repair the damaged components. The assembly and disassembly of the rawin set should progress from one component to the next in an orderly manner. When properly loaded in the $1\frac{1}{2}$ -ton, 2-wheel cargo trailer

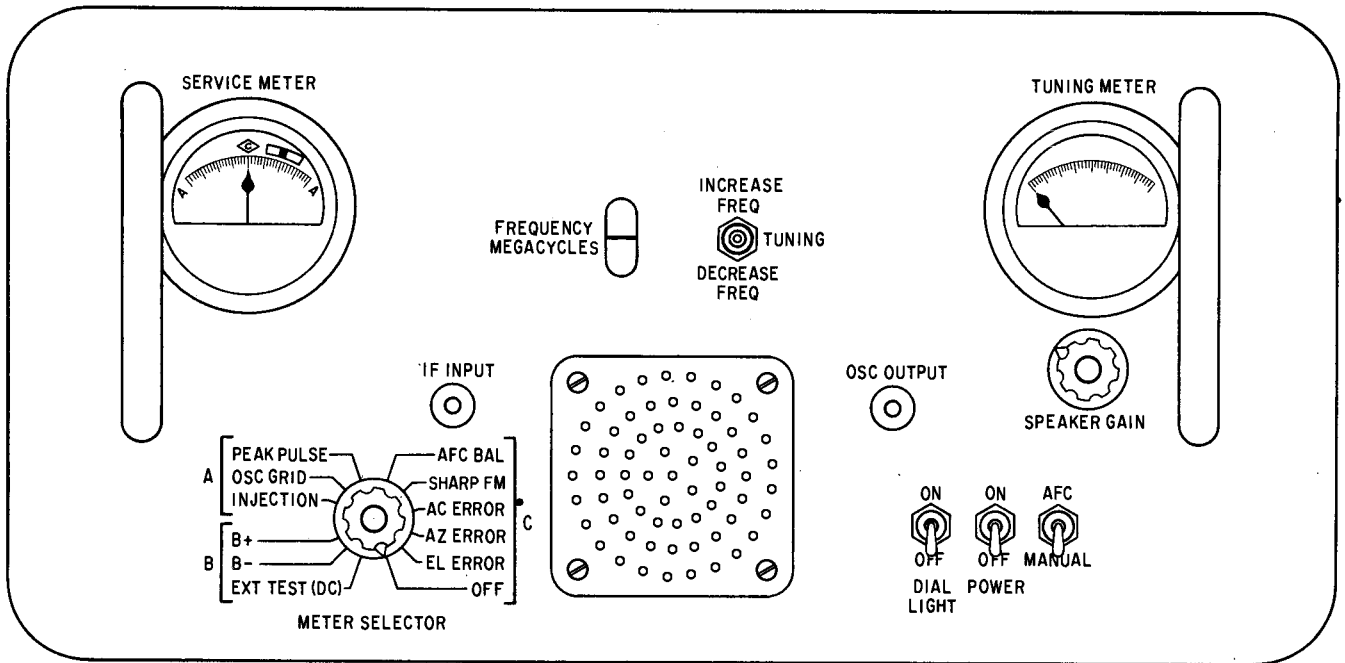

① receiver panel
 Figure 50. Rawin set controls.

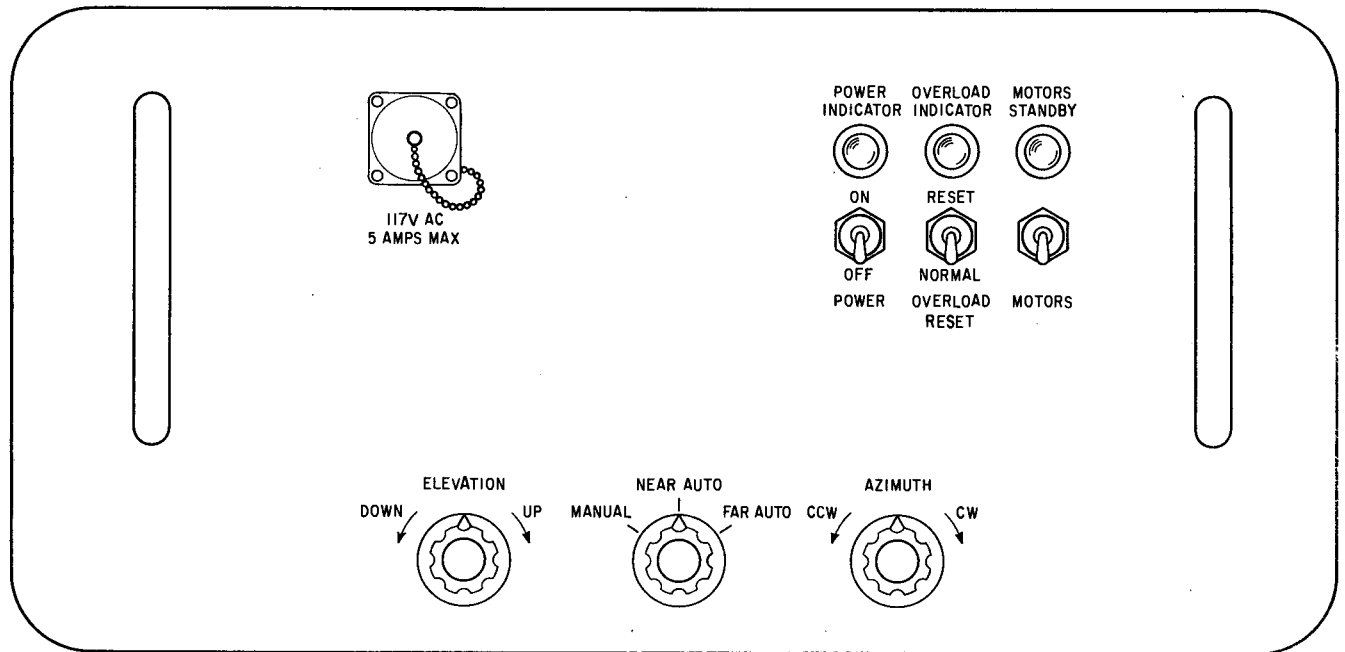

② antenna control panel
 Figure 50—Continued.

(models M104 and M105) using the trailer adapter kit, the rawin set can be transported from one position to another without being damaged. For detailed information on assembly, disassembly, and loading of the rawin set, see TM 11-6660-206-10.

78. Operation

a. *Controls.* The controls for operation of the rawin set are on the components of the main assembly and control-recorder. The rawin receiver panel (①, fig 50) has six switches to operate, tune,

and test the receiver. The antenna control panel (⊙, fig 50) has four switches, an azimuth potentiometer and an elevation potentiometer. In addition, there is a separate set of manual positioning controls on the left side of the housing (not shown in fig 50).

b. Control-Recorder. Power for the entire rawin set is supplied through the MAIN FUZES and the MAIN POWER switch of the control-recorder (fig 51). The MANUAL CONTROL ELEVATION and AZIMUTH switches are employed to remotely control the positioning of the rawin set. A MOTORS STANDBY switch is available to operate the antenna scanner motor and the tracking elements from the control-recorder position. ELEVATION and AZIMUTH RESET SELECTORS (mechanical clutches) and the RESET CONTROL knob are used to orient the elevation and azimuth indicator dials and the printing mechanism. The TIME RESET knob is used to reset the visual time indicator and time printing mechanism. The PRINTINGS-PER-MINUTE switch controls the number of prints per minute of the recording system. The RECORDS CONTROL switch insures coordination of the entire rawinsonde system at the release of a radiosonde. A set of lights indicates a power interruption and warns the operator that reorientation of the data recording system may be required.

c. Starting Procedure. The rawin set is placed in operation by placing the MAIN POWER switch on the control-recorder in the ON position. Normally, the power switches on the antenna control and rawin receiver are left in the ON position; the MOTORS STANDBY switch should be in the STANDBY position.

d. Preflight Procedure. The antenna reflector is positioned to face the radiosonde. On the receiver panel (fig 50), the FREQUENCY MEGACYCLES dial is set to the highest obtainable reading on the tuning meter by pushing the TUNING switch to the INCREASE FREQ or DECREASE FREQ position. The AFC (automatic frequency control)-MANUAL control is switched from MANUAL to the AFC position. Normally, the automatic frequency control will lock on the radiosonde frequency and accurately tune the receiver. When the receiver is properly tuned, the TUNING METER should read 60 or more units, and the audio signal should be heard. (If the TUNING METER reading is too high, the meteorological signal may be distorted during the baseline check. This distortion can be eliminated by positioning the antenna reflector off target.) The automatic tracking system of the rawin

set is checked by switching the MANUAL-NEAR AUTO-FAR AUTO switch to the NEAR AUTO position. The rawin set should position itself approximately on the radiosonde transmitter. The antenna reflector is repositioned to obtain 60 or more units on the receiver TUNING METER. The motors are turned off by switching the MOTORS switch to STANDBY (MOTORS STANDBY lamp lights). On the control-recorder, the RECORDS CONTROL switch is switched to the BASELINE CHECK position and the baseline check is performed. After the baseline check has been verified and the reference-temperature-humidity check is performed, the RECORDS CONTROL switch is positioned to STANDBY and the MOTORS turned on. The radiosonde is prepared for release.

e. Flight Procedure. At the instant the radiosonde is released, the RECORDS CONTROL switch is switched to the FLIGHT position. This causes simultaneous starting of the control-recorder, the radiosonde recorder, and the rawin set. The section chief stands by to insure that the rawin set is tracking on target. Normally, the rawin set will automatically track the radiosonde from release when the MANUAL-NEAR AUTO-FAR AUTO control on the antenna control (⊙, fig 50) is in the NEAR AUTO position. The radiosonde should be released 100 meters or more downwind from the main assembly to facilitate automatic tracking and thereby obtain valid data from the ground level upwards. Approximately 2 minutes after release of the radiosonde, the section chief switches the MANUAL-NEAR AUTO-FAR AUTO switch to the FAR AUTO position.

f. Stopping Procedure. Generally, the flight should be terminated on the next low reference after the required altitude has been attained, on the first high reference after balloon burst, or when the critical angle has been reached. The critical angle is defined as an angle of 6° above or to the side of any object on the horizon. When the critical angle has been reached, wind data become invalid. However, the evaluation of temperature and density may continue as long as a requirement for these data exists. When the flight is terminated, the rawin set is stow locked in both azimuth and elevation. After the set is stow locked, the MAIN POWER switch on the control-recorder is placed in the OFF position. This procedure will prevent misorientation of the rawin set due to antenna movement while the remote control angle indicating and recording system is not energized.

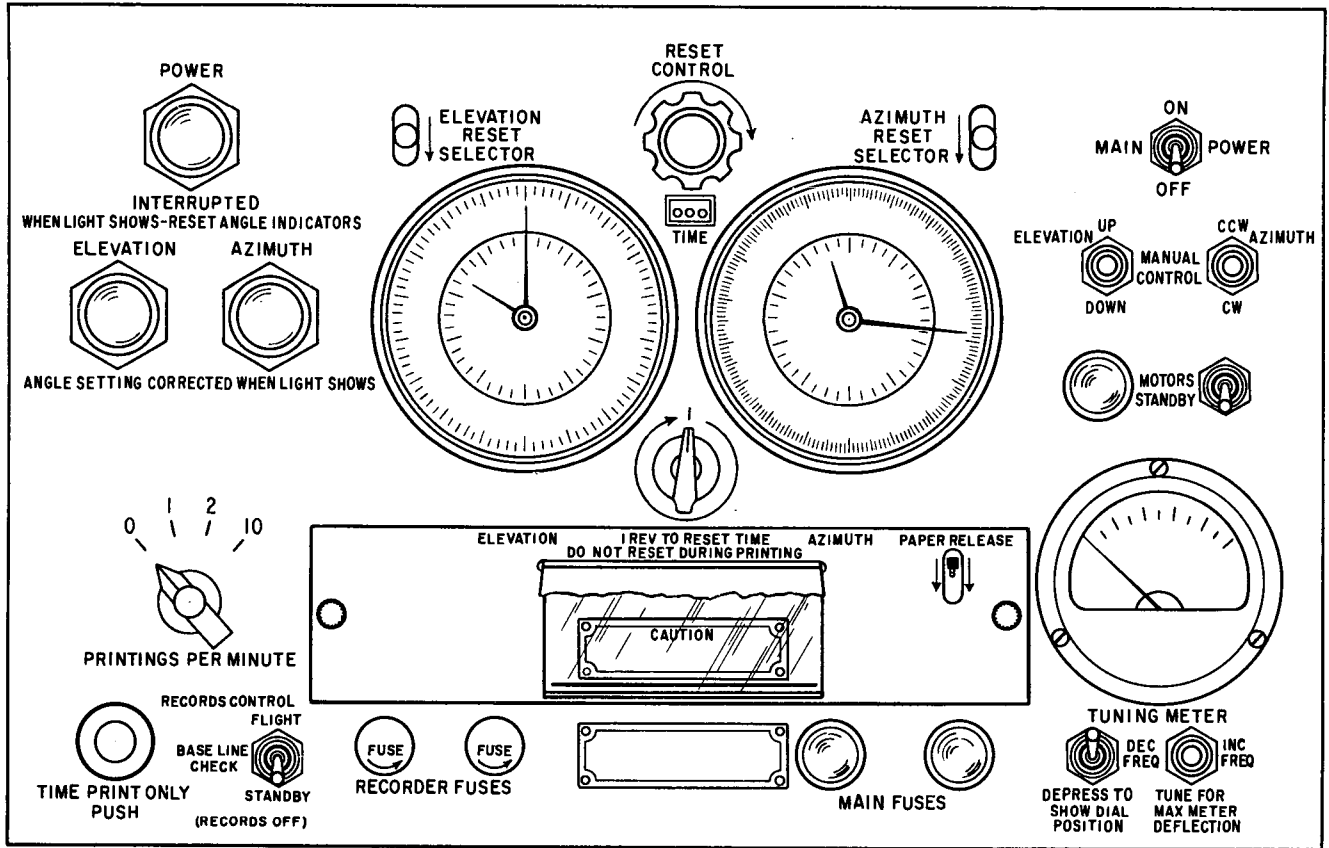

Figure 51. Control-recorder.

79. Optical-Electrical Bearing Check

The optical-electrical bearing check is performed to insure that the optical axis of the telescope is parallel to the electrical axis of the rawin set.

a. *Performing the Bearing Check.* The telescope of the rawin set is used to perform the bearing check. No sooner than 5 minutes after release of the radiosonde (unless low clouds indicate a surface check), the radiosonde is viewed through the telescope. If the radiosonde is centered in the reticle, the optical and electrical axes are parallel and no further action is required. If the radiosonde is not centered in the reticle, the necessary angular corrections are determined on the reticle scales. The telescope is then adjusted to center the radiosonde in the reticle, thereby making the optical axis parallel to the electrical axis. The corrections noted are applied to all of the angular data extracted from the control-recorded paper tape. At the end of the flight, the rawin set is reoriented.

b. *Preflight Check of Telescope Alinement.* A preflight adjustment of the telescope can be made by using an optical-electrical bearing check

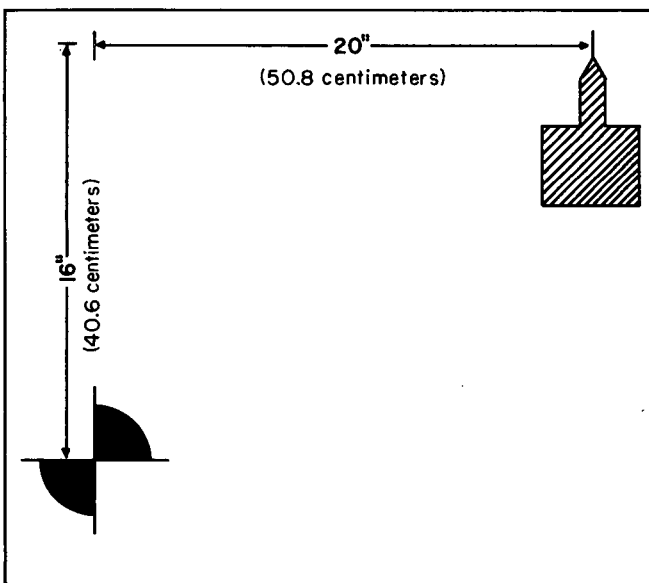

Figure 52. Optical-electrical bearing check board.

**FOURTH QUADRANT
ANGULAR CORRECTIONS**

ARE:
PLUS for Elevation
MINUS for Azimuth

**FIRST QUADRANT
ANGULAR CORRECTIONS**

ARE:
PLUS for Elevation
PLUS for Azimuth

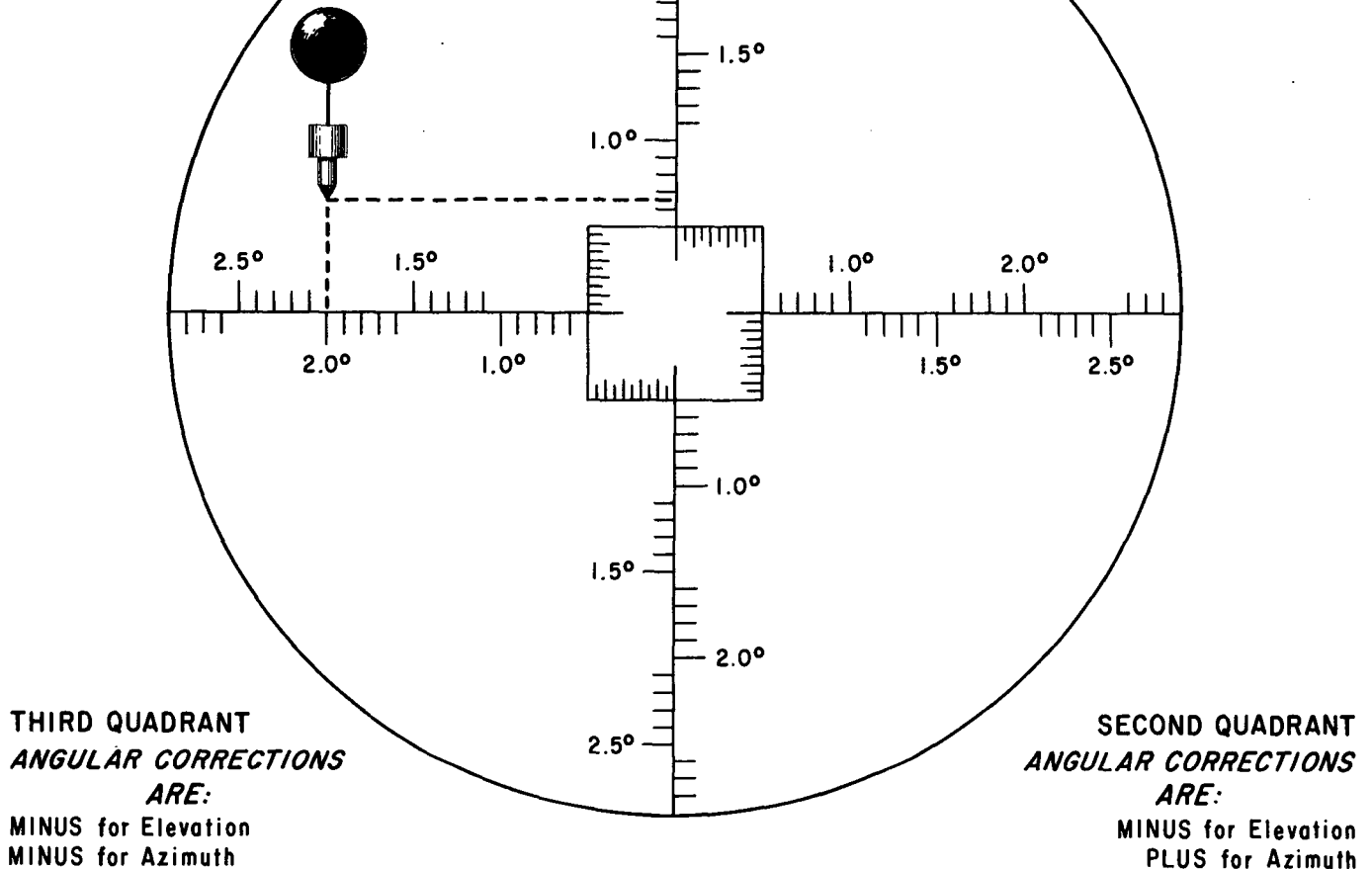

**THIRD QUADRANT
ANGULAR CORRECTIONS**

ARE:
MINUS for Elevation
MINUS for Azimuth

**SECOND QUADRANT
ANGULAR CORRECTIONS**

ARE:
MINUS for Elevation
PLUS for Azimuth

Figure 53. Determining angular corrections.

board. This board may be used when poor visibility prevents a visual check of the radiosonde after its release.

(1) The optical-electrical bearing check board (fig 52) is used in a manner similar to the manner in which the test target is used in bore-sighting a howitzer.

(2) To build the optical-electrical bearing check board, use a radiosonde and a sheet of plywood approximately 2 feet square. At the upper right corner of the plywood, mount the radiosonde with the transmitter in a vertical position as shown in figure 52. Twenty inches to the left and 16 inches below the center of the transmitter antenna, drill a small hole on which to center a crosshair pattern. Paint in the crosshairs and then paint the first and third quadrants of the crosshair pattern so that the center will be plainly visible through the telescope of the rawin

set. A light can be placed behind the hole for checking bearing at night. To perform the bearing check, activate the radiosonde and place the board at least 50 meters from the rawin set and about 4 meters above the ground. With MANUAL-NEAR AUTO-FAR AUTO switch in the FAR AUTO position and the rawin set tracking the target, adjust the telescope until the crosshairs on the reticle are alined with the crosshair pattern on the check board. After this adjustment, the transmitter should "jiggle" in the center of the reticle during an actual flight, and the correction for parallax does not have to be made. In a semipermanent position, a fixed upright can be constructed upon which to mount the test board. This upright can be surveyed in to serve as an azimuth reference point during orientation.

c. *Determination of Angular Corrections.* The angular corrections to be applied to the elevation

and azimuth data extracted from the control-recorder tape are determined from the horizontal and vertical scales in the reticle of the telescope (fig 53). The vertical scale is used to determine the correction for elevation angles, and the horizontal scale is used to determine the correction for azimuth angles. These scales divide the reticle of the telescope into four quadrants. The corrections are read directly from the scales to the nearest 0.1° . If the radiosonde appears in the upper half of the reticle, the elevation correction is added to each elevation angle extracted from the tape; if it appears in the lower half of the reticle, the elevation correction is subtracted from each elevation angle. If the radiosonde appears in the right half of the reticle, the azimuth correction is added to each azimuth angle extracted from the tape; if it appears in the left half of the reticle, the azimuth correction is subtracted from each azimuth angle. The signs of the elevation and azimuth corrections for each quadrant are shown in figure 53. For the radiosonde illustrated in the figure, the elevation correction is $+0.60^\circ$ and the azimuth correction is -2.0° .

Section VIII. RADIOSONDE RECORDER AN/TMQ-5()

81. General

The purpose of radiosonde recorder AN/TMQ-5() (fig 54) is to provide a means of recording the meteorological data, except winds, received by rawin set AN/GMD-1().

82. Description and Use

The radiosonde recorder converts the net signal from the rawin set to a visual record. Circuits within the radiosonde recorder first convert the met signal to a direct current (DC) voltage proportional to pulse frequency. This voltage is compared with another voltage which is representative of the recorder pen position. The difference between these voltages causes the pen to move to the proper recording position. In conjunction with a radiosonde, and a rawin set, the radiosonde recorder produces an accurate record of the atmospheric sounding during a radiosonde flight. For detailed information, see TM 11-6660-204-10.

83. Controls

The controls required for operation of the radiosonde recorder are on the front panel of the recorder. These controls are used to regulate and adjust the sensitivity of the pen positioning circuits and the operation of the pen lifter circuits. The controls also are used to make compensations for drift of the radiosonde transmitter signal.

d. Application of Angular Corrections. The angular data printed by the control-recorder will be in error if the radiosonde is not centered in the reticle of the telescope. These data are corrected by adding or subtracting the angular corrections determined in *c* above. Only the angular data which are to be used in subsequent computations are corrected.

e. Frequency of Performance. The optical-electrical bearing check is performed during the first radiosonde flight after the rawin set is installed in a new location. The check is also performed at least once each day the rawin set is used or at any time the telescope alignment is disturbed. If the radiosonde does not appear initially in the reticle of the telescope, the procedures outlined in TM 11-6660-206-10 should be employed to obtain accurate angular data.

80. Preventive Maintenance

The preventive maintenance to be performed by the operator is specified in TM 11-6660-206-10. Troubleshooting by the operator is limited primarily to power troubles. The greatest single source of trouble is improper cable connections.

84. Installation

The radiosonde recorder is normally located in the met van. It should be installed on mount MT-1355/TMQ-5 where it can be easily connected to the control-recorder. Two cables are commonly used in the operation of the radiosonde recorder. Cable CX-1217/U provides a connection from the radiosonde recorder to the control-recorder of the rawin set. During operation of the rawinsonde system, this cable carries the necessary power to operate the radiosonde recorder, the met signal, and provides the wires for the automatic rawin time print system. Cable CX-2337/TMQ-5 is a split cable which may be connected to a wall receptacle to supply power to the radiosonde recorder. Two leads are left free to provide for a signal input. This cable is used during the linearity calibration of the radiosonde recorder with frequency standard TS-65()/FMQ-1.

85. Operation

a. Preset Procedures. The operator prepares the radiosonde recorder for operation by opening the cooling vent, erecting the desk, advancing the chart, and attaching the chart weight.

b. Preliminary Starting Procedure. Allow the set to warm up for 15 minutes. This should be done with the POWER ON-POWER OFF-STAND BY switch in the STAND BY position

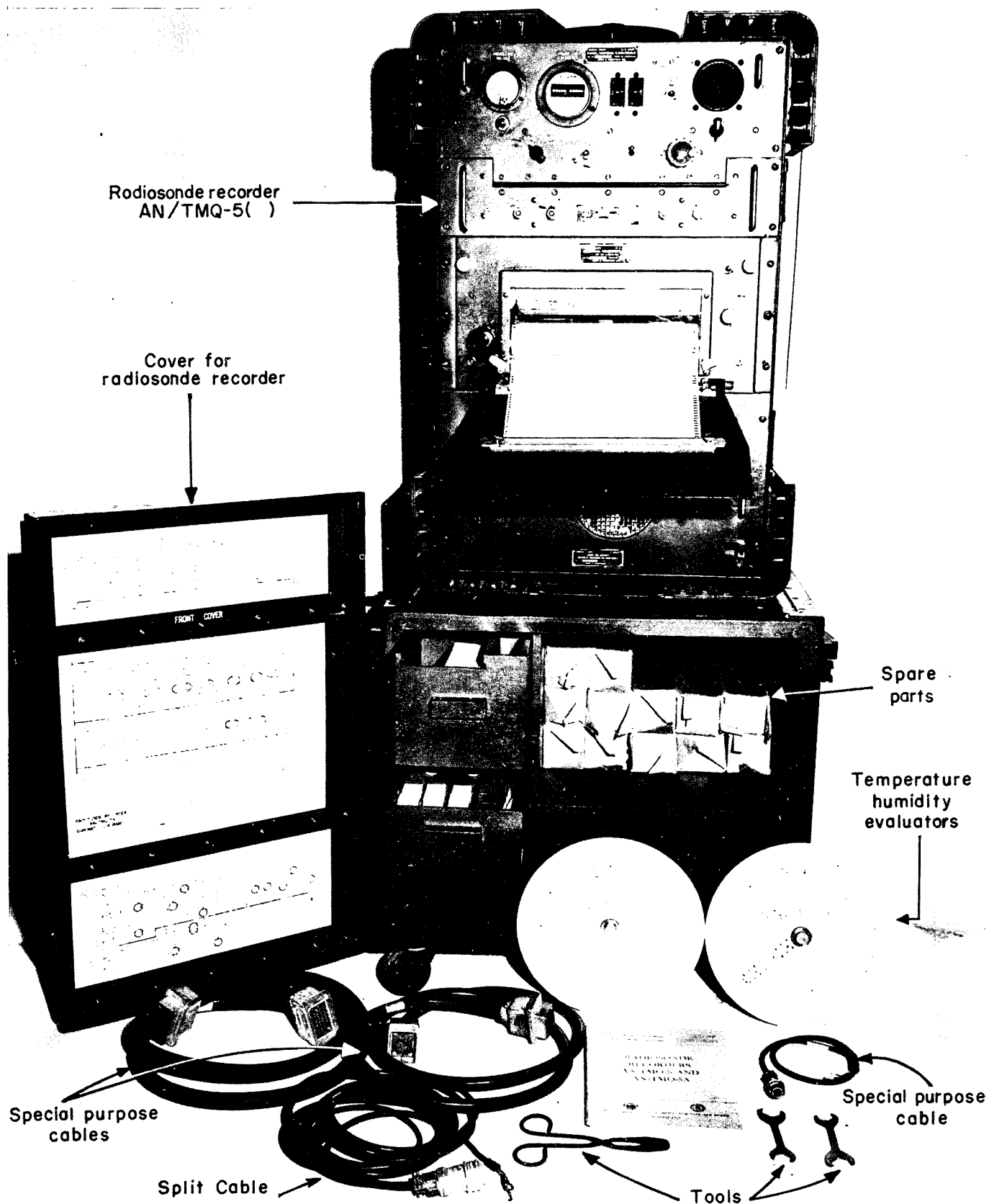

Figure 54. Radiosonde recorder AN/TMQ-5().

and the cooling fan operating. The power and frequency meters should be checked for correct values (105 to 125 volts and 50 to 60 Hz). If necessary, the power source should be adjusted to obtain these values.

c. Starting Procedure. After the warmup period, the POWER ON-POWER OFF-STANDBY switch is placed in the POWER ON position. With the SIGNAL SELECTOR switch still in the SC (short circuit) position, the pen should record at zero on the chart. If the pen does not print at zero, the maintenance technician should be informed. Check the chart alinement by manually advancing the chart and observing the relationship between the chart and the studs at the left edge of the roller. If, as the chart advances, the chart creeps to the right or left as shown by the left-hand holes in the chart and the chart roller studs, the chart must be realined. Next, hold the REC TEST switch in its down position; the pen should move to 95 recorder divisions and mark the chart. This test insures that the pen will move freely to the right side of the chart. When the SIGNAL SELECTOR switch is set to 60 cps the pen will move to 30 on the recorder chart. If not, adjust to 30 recorder divisions by rotating the REF ADJUST handwheel. (This reading is one-half the line frequency.) After making the pen print at 30 recorder divisions on the chart, rotate the SIGNAL SELECTOR switch to the 120-cps position. The pen should move to 60 recorder divisions. The pen can be positioned by rotating the REF ADJUST handwheel. After completing these tests, rotate the SIGNAL SELEC-

TOR switch to SIG position. The recorder is now ready to receive and record signals.

86. Calibration

Linear calibration is performed with frequency standard TS-65()/FMQ-1 by injecting selected groups of fixed frequencies that are accurate between 10 and 190 hertz. This calibration normally is performed by the recorder operator as prescribed in TM 11-6660-204-10. If the calibration fails to meet the criteria as outlined in TM 11-6660-204-10, the maintenance technician is consulted. Linear calibration is to be performed each time the recorder is moved, after major maintenance, or monthly.

87. Preventive Maintenance

a. Daily. The recorder operator checks for completeness and general condition of the equipment; inspects for clean impression of printing and proper recorder paper feed; checks input voltage and frequency readings for proper values; and checks for normal operation by performing the preset, preliminary, and starting procedures.

b. Weekly. The maintenance technician, assisted by the operator, tightens, the mounting and the camlock fasteners on the cabinet; cleans and tightens the cable connectors; cleans the cabinet of rust, corrosion, and moisture; inspects the wires, cables, cord, and shock mounts for cuts, breaks, fraying, deterioration, kinks, and strain; cleans the meter windows; inspects the meters for damaged glass and cases; and checks the voltmeter for zero adjustment.

Section IX. CALIBRATION EQUIPMENT

88. Frequency Standard TS-65()/FMQ-1

a. Purpose. The purpose of frequency standard TS-65()/FMQ-1 (fig 55) is to provide a means for linear calibration of the radiosonde recorder AN/TMQ-5().

b. Description and Use. Frequency standard TS-65()/FMQ-1 is a rugged electronic unit designed to provide accurate electrical signals of fixed frequency between 10 and 190 hertz. It is issued to meteorological sections for the linearity calibration of radiosonde recorder AN/TMQ-5(). The standard is a self-contained unit which operates on 110 volt alternating current at 50 to 60 hertz. For detailed information, see TM 11-2602B.

c. Preventive Maintenance. Since frequency standard TS-65()/FMQ-1 is the only instrument available for performing a linearity calibration of the radiosonde recorder, the handling and

operating instructions should be followed carefully. Always protect it from jarring, and report any evidence of improper functioning to the maintenance technician. Proper operation of the frequency standard can be determined by observing the light pattern through the SYNC (synchronization) hole on the front panel. A stationary pattern indicates proper operation.

89. Radiosonde Baseline Check Set AN/GMM-1()

a. Purpose. The purpose of radiosonde baseline check set AN/GMM-1() (fig 56) is to provide a stable environment for the testing and preflight calibration of the radiosonde temperature and humidity sensing elements. In addition, the baseline check set may be used to set the pin arm of the radiosonde.

b. Description and Use. The set consists of a temperature-humidity chamber, a control unit, a

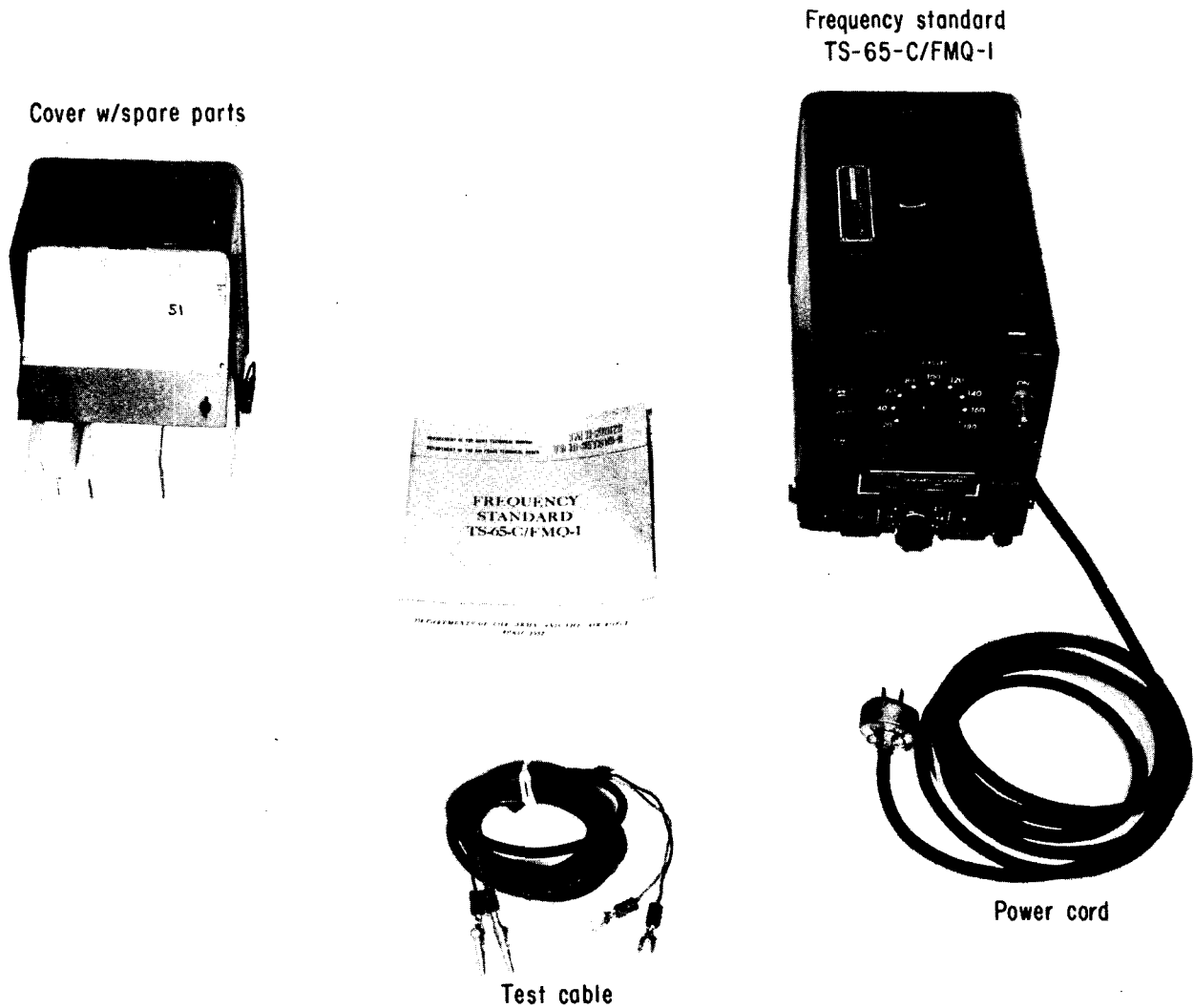

Figure 55. Frequency standard TS-65()/FMQ-1.

psychrometer case, a 30-meter remote cable, and a 4.5-meter power cable. The chamber is provided with an air circulating fan, water tray, and heater. An electrical switch is installed to permit remote selection of the radiosonde circuits, either manually or automatically. An illuminated psychrometer is mounted inside the chamber and is visible through the door window so that chamber conditions can be measured without disturbing the chamber atmosphere. Connections are provided to power the radiosonde from a battery outside the chamber, so that the battery heat and moisture will not affect the chamber conditions. The psychrometer case, which contains two psychrometers ML-224, spare tubes, and wicks, is mounted on top of the chamber. During operation, one psychrometer is installed in the check set chamber and the other is used for local surface observations. The control unit for the baseline check set can be mounted on top of the cham-

ber or at a remote location by use of the reel unit, which has 30 meters of interconnecting cable. For detailed information, see TM 11-6660-219-12.

c. Installation. The baseline check set should be placed in a shaded location where it is protected from the direct rays of the sun. The path between the check set and the rawin antenna must be free of any obstacles, such as earth and large metallic objects, that would block the transmitted signal. Radio transmitters, electrical machinery, high-tension power lines and communication lines may cause interference and must be avoided in the selection of the site. Avoid movement of personnel in the vicinity of the check set, as such movement may cause interference with the transmitted signal. To facilitate baseline check procedure, the control unit is placed inside the shop van where it can be operated by the radiosonde recorder operator. Because of the length of the control unit

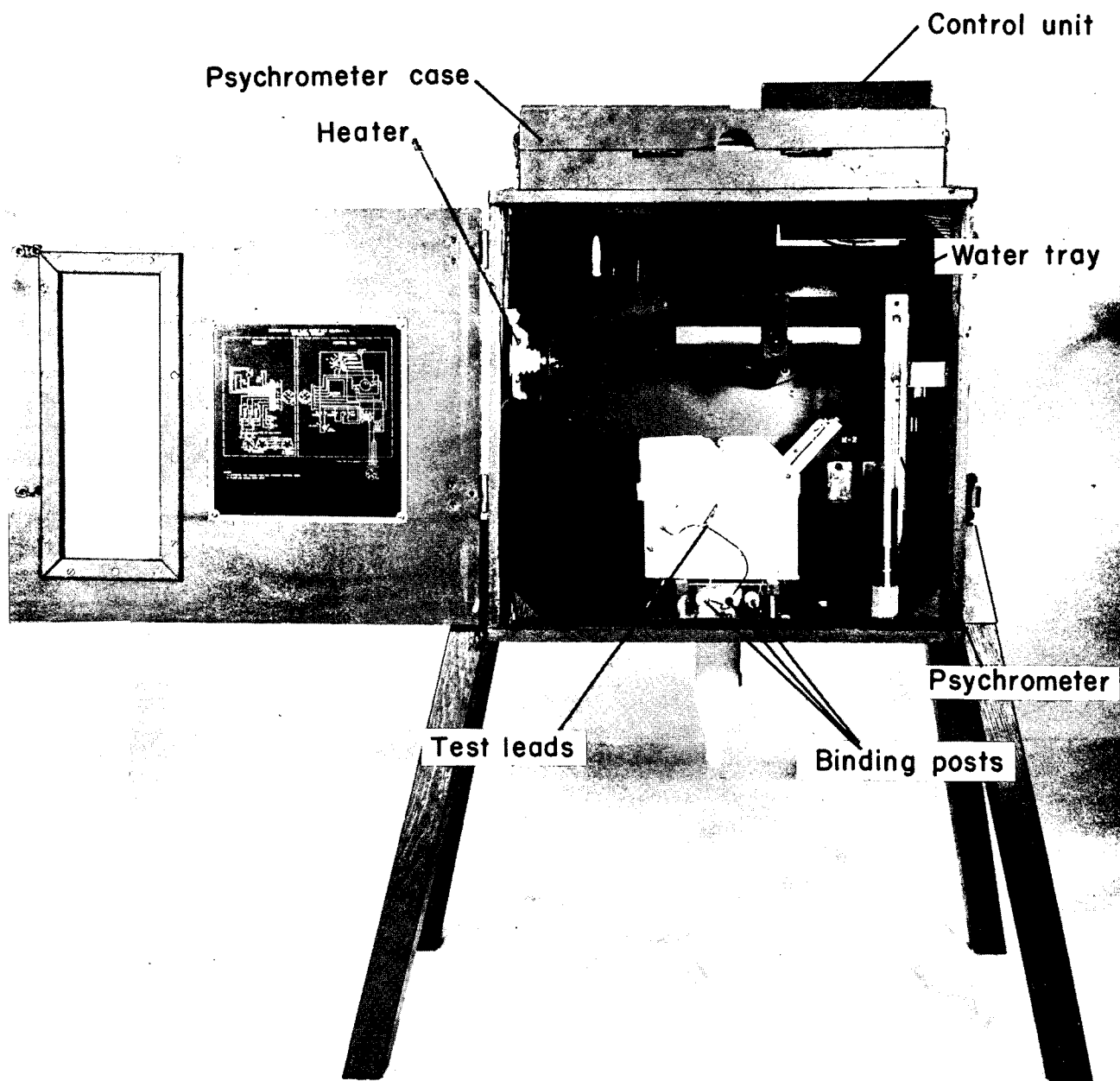

Figure 56. Radiosonde baseline check set
AN/GMM-1().

cable, the check set must be installed within 30 meters of the shop van.

d. Operation. The control unit may be installed and operated either on the top of the atmospheric chamber or at a remote location. The POWER switch controls power to the FAN, HEATER, and LIGHT switches and to the pin arm adjustment circuit. When the main power is turned on, the FAN, HEATER, and LIGHT (chamber light) switches will operate, but the heater will not turn on unless the fan is on. For baseline check operations, the fan is always turned on. The heater may be used, if necessary, to raise the

temperature inside the chamber above freezing. The selector switch takes the place of the radiosonde baroswitch by causing the radiosonde to transmit temperature, low reference, or humidity signals. The selector switch is turned manually to the TEMPERATURE, REFERENCE, or HUMIDITY position. When the selector switch is turned to its last position, AUTOMATIC, the radiosonde switching is controlled by a small motor which connects the low reference, temperature, low reference, humidity, in that order, at 15-second intervals. The high reference circuit is not tested by the baseline check set. As soon as the

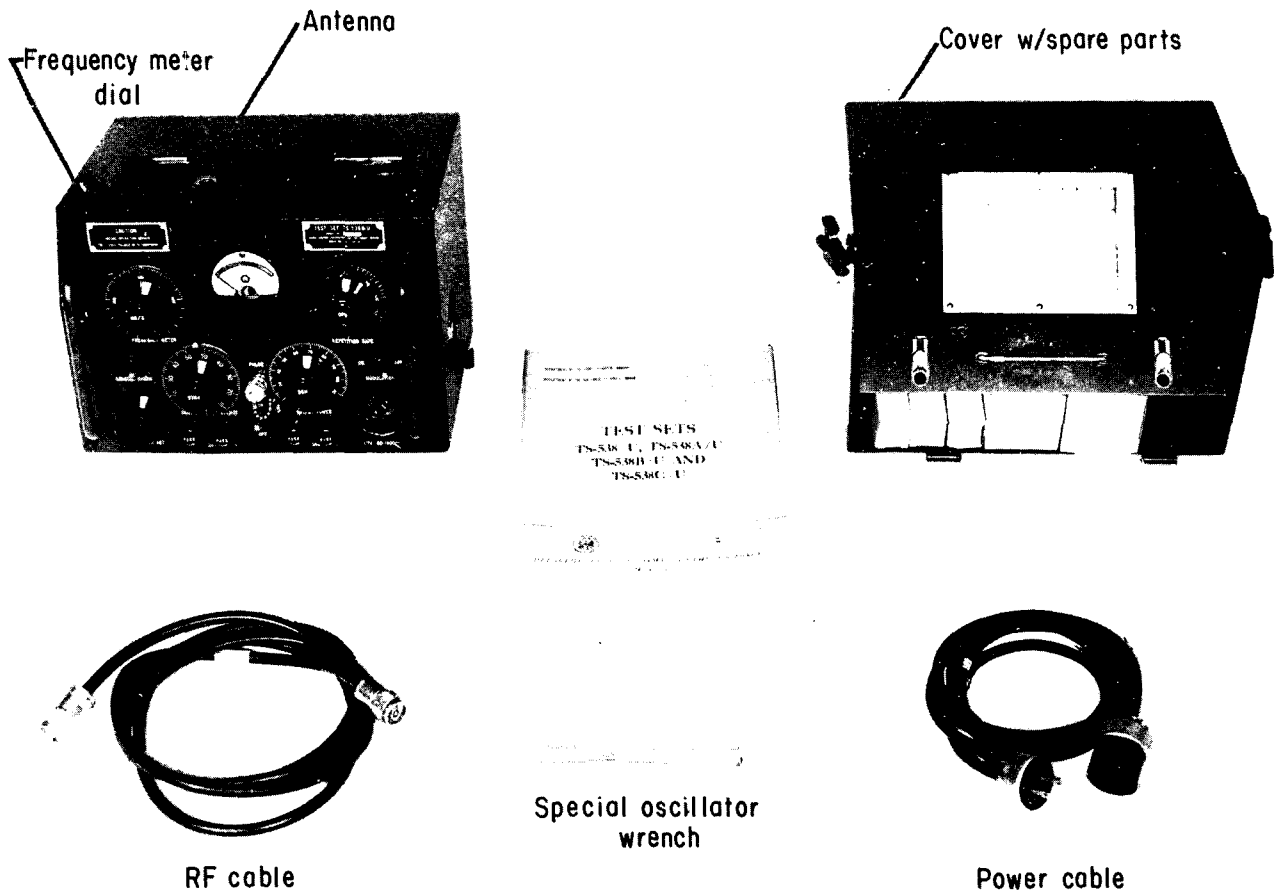

Figure 57. Test set TS-538/U.

sensing elements are installed on the radiosonde, the radiosonde is placed in the check set chamber, with the transmitter protruding through the aperture in the floor of the chamber and the temperature element toward the psychrometer. Extreme care must be taken in handling the delicate temperature elements, which are easily broken. The radiosonde test leads are connected to the test terminals in the baseline check set chamber. The pin arm of the modulator is left *off* (up). Then the door is closed. An interval of approximately 10 minutes is required to achieve stable conditions of temperature and humidity. After the radiosonde is installed in the atmospheric chamber and the door is closed, the baseline check is conducted as described in chapter 7.

e. Preventive Maintenance. Detailed maintenance instructions for the radiosonde baseline check set are contained in TM 11-6660-219-12.

90. Test Set TS-538/U

a. Purpose. Test set TS-538/U (fig 57) provides a means for checking the frequency and signal strength of the radiosonde transmitter. It may also be used as a signal generator.

b. Description and Use. Test set TS-538/U is a component part of the rawin set. The test set is contained in a metal case with a hinged cover. The power cable and antenna are stored inside the cover. When used as a signal generator, the test set requires 60-hertz, 110-volt power. When the test set is used to check the frequency and the signal strength, external power is not required. Only the FREQUENCY METER dial and the POWER MONITOR are used to check the frequency and the signal strength. For a detailed description, see TM 11-6625-213-12.

c. Operation. The test set is used to measure the frequency and the power output of the radio-

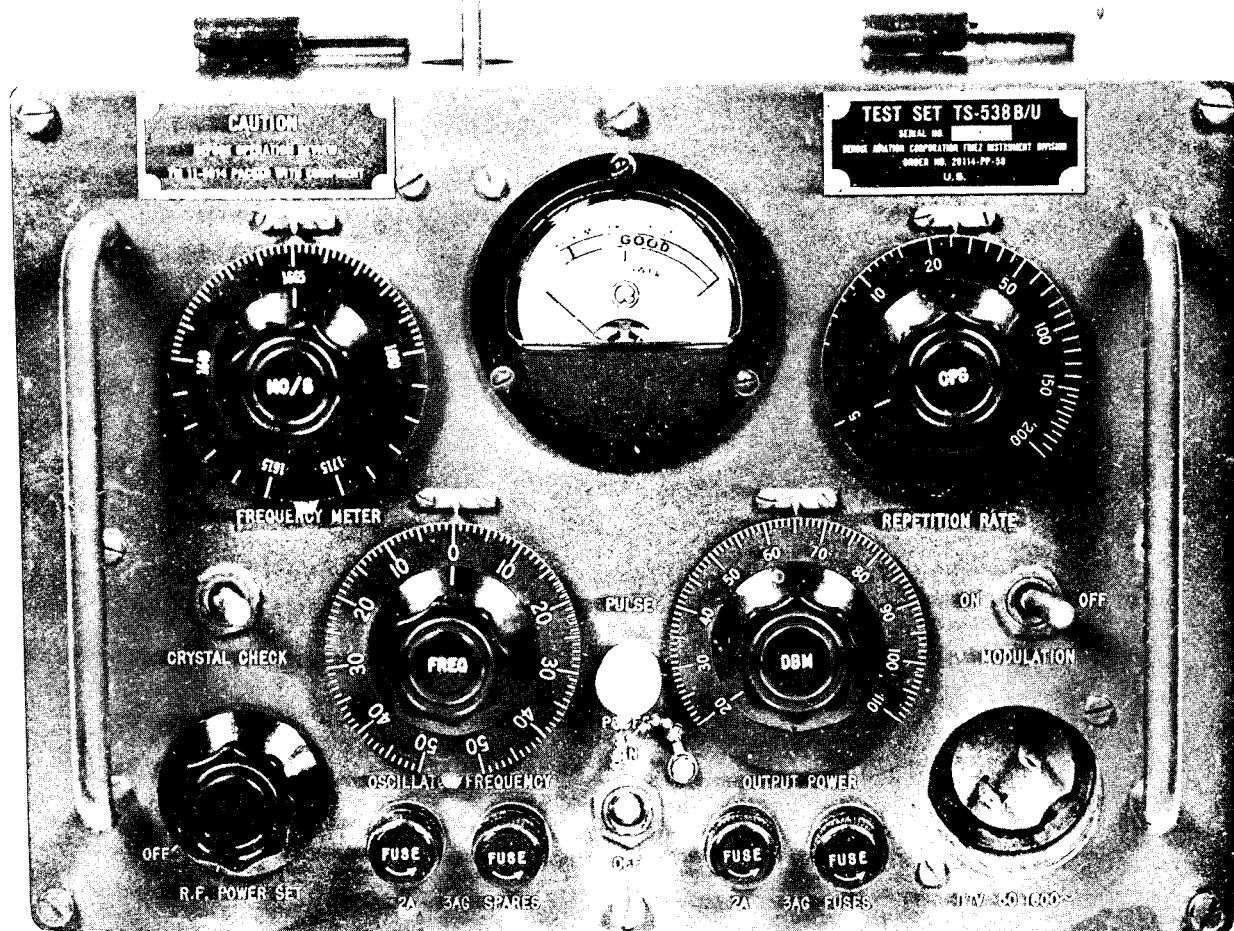

Figure 57—Continued.

sonde transmitter. The operation of the test set in performing these functions is described in chapter 7.

d. Preventive Maintenance. Detailed procedures for maintenance of the test set are outlined in TM 11-6625-213-12.

Section X. POWER UNITS

91. Power Unit, 10 Kilowatt

a. Purpose. The purpose of the 10-kw power unit (fig 58) is to provide a power source for operation of the meteorological station.

b. Description and Use. The complete electronic meteorological section operating in the field requires approximately 2,300 watts of electric power for the equipment alone. Electric lights, soldering irons, and electrical test equipment require additional power. The rawinsonde system makes many measurements of minute electrical quantities in its automatic recording of radio-sonde data, therefore, the system must be provided with an adequate and stable power source.

The power unit must provide stable voltage and deliver power at a fixed frequency, regardless of the load. Due to the different models of generators which may be issued to met sections, appropriate manuals should be consulted for operations, adjustments, and preventive maintenance.

92. Power Unit PE-75-()

a. Purpose. Power unit PE-75-() (fig 59) is provided for use by the electronic meteorological section in case of failure of, and during periods of routine maintenance on the 10-kw power unit.

b. Description and Use. Power unit PE-75-() is a small, portable field generator weighing ap-

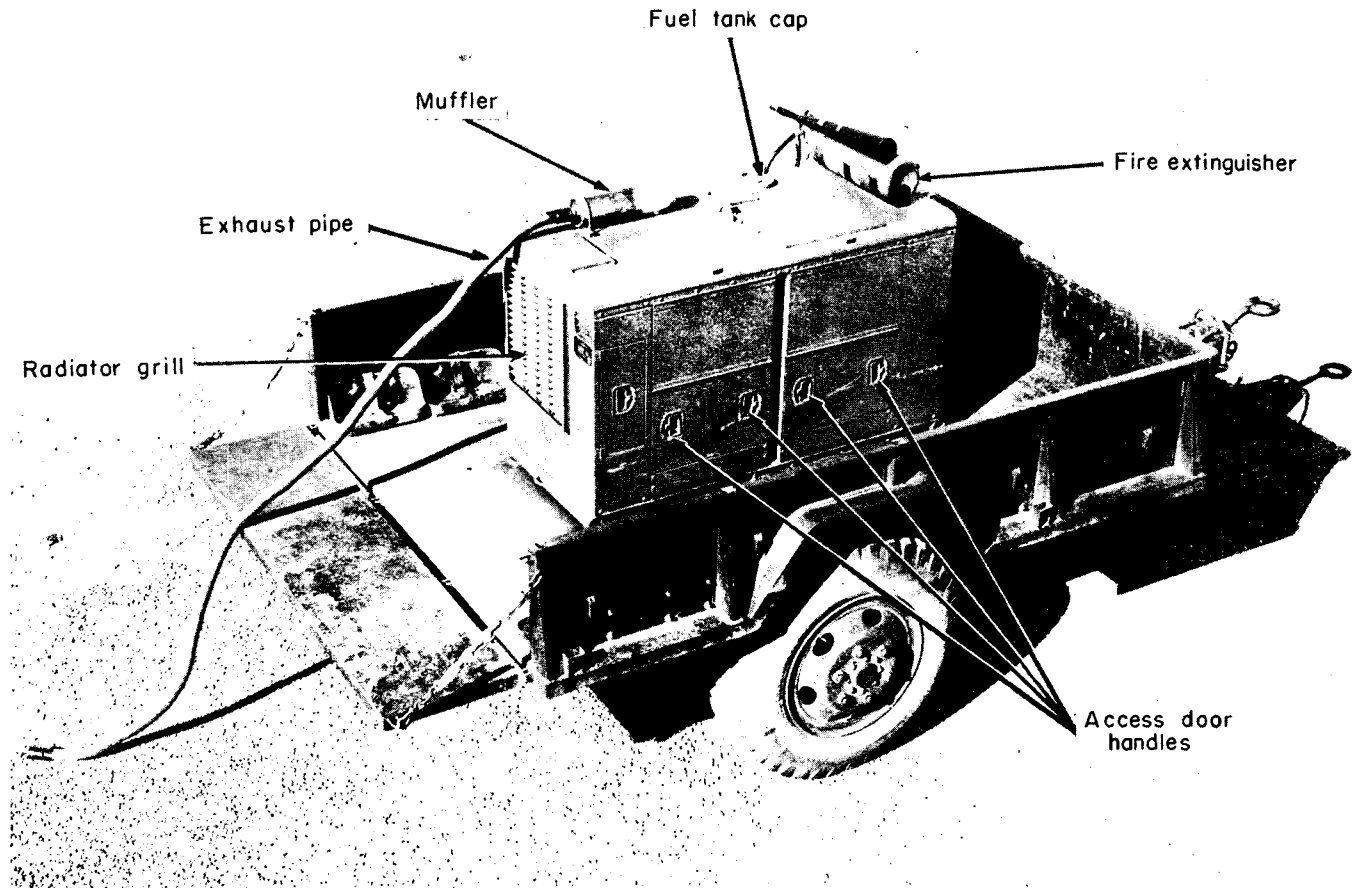

Figure 58. Power unit, 10-kw.

proximately 319 pounds and powered by a single cylinder, 4-cycle gasoline engine. Power unit PE-75-() is capable of providing 2,500 watts of electric power continuously at 120 volts and 60 hertz. It is started with a flywheel pull cord and stopped with a magneto disconnect button located at the top of the flywheel housing. The unit will satisfactorily operate the rawinsonde system, but care must be exercised not to overload the generator with accessories. This generator is not protected against electrical overload. Means are provided to adjust the frequency of the electrical generator power. This adjustment should be made while the generator is under normal load. The frequency can be measured on the POWER LINE FREQUENCY meter on the radiosonde recorder.

c. Starting and Stopping Procedures.

(1) *Starting.* The first step in starting the power unit is to wind the starting rope around the crankshaft pulley wheel on the flywheel housing side of the engine. Open the gasoline shutoff valve. Pull the starting rope slowly to determine

if all internal parts of the power unit will move freely without abnormal drag or friction. To start the engine, the starter rope is wound on the starter pulley and pulled with a quick steady motion. If the engine does not start after it has been cranked three or four times with the choke closed, it should be cranked several times with the choke partially open and then with the choke wide open. Do not race a cold engine. If the engine does not start, the met maintenance technician should be consulted.

(2) *Stopping.* The following procedure is used to stop the power unit PE-75-(). The STOP button on the flywheel blower housing is depressed and held down until engine stops. If the engine has been operating for several hours, it may be necessary to depress the stop button for 30 seconds or more. If the engine is not to be used again for a period of 4 hours or more, it should be stopped by closing the shutoff valve on the fuel filter under the fuel tank.

d. Operation. The power unit operates in the same manner as the engine of a motor vehicle.

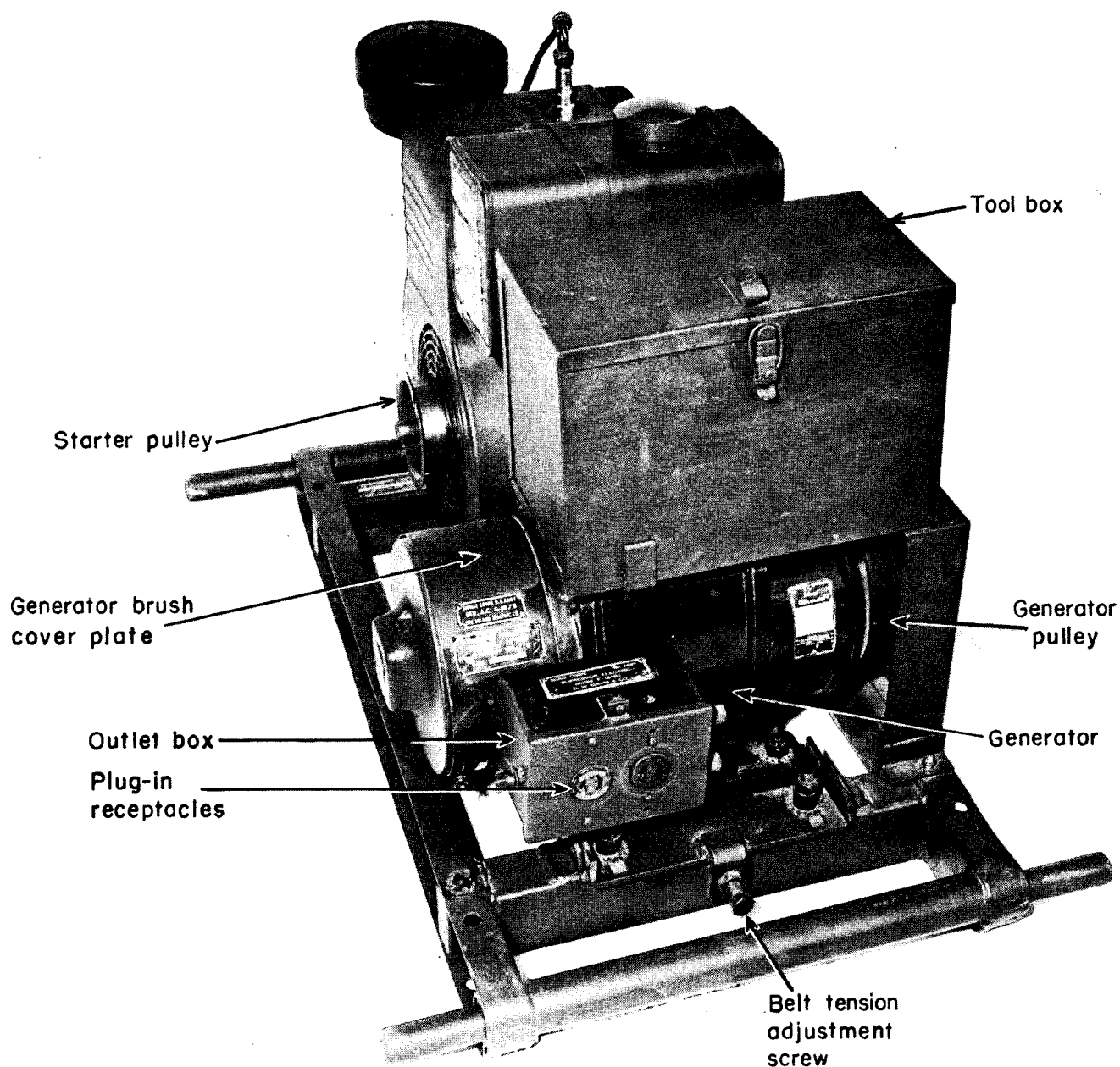

Figure 59. Power unit PE-75-().

During operation, the operator should listen for any unusual noises, such as backfiring, missing, or rattling. If any unusual noises are heard, corrective action should be taken as soon as possible.

e. Adjustments. After the engine starts running, the choke should be gradually opened by moving it counterclockwise until the engine runs smoothly with the choke fully open. If the engine does not run smoothly with the choke fully open, the needle valve is turned counterclockwise. If the engine continues to run abnormally (misses,

backfires, etc), the needle valve is turned clockwise until the engine runs smoothly. A load should not be placed on the engine until it has reached normal operating temperature, which will occur approximately 15 minutes after starting.

f. Preventive Maintenance. The principles of operation, care, and maintenance of the 10-kw power unit apply to power unit PE-75-() with few exceptions.

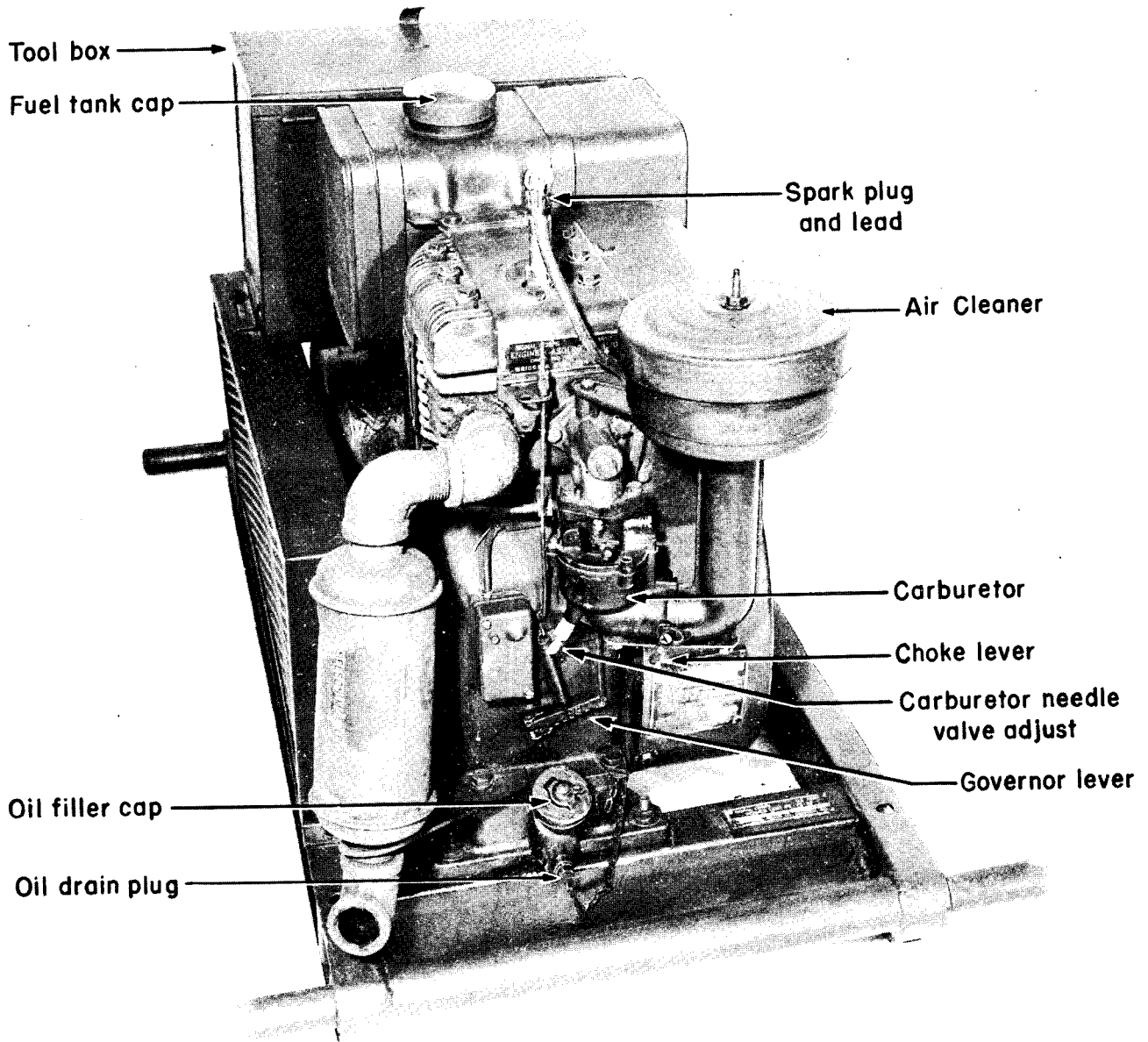

Figure 59—Continued.

CHAPTER 7

OBSERVATION TECHNIQUES

Section I. ORGANIZATION OF TEAMS

93. General

In this chapter the organization and operations of a ballistic meteorological section are explained in detail. The training of meteorological teams is related to the step-by-step procedures involved in obtaining and computing the various meteorological elements for a completed computer and NATO meteorological message. All artillery meteorological sections operate in a similar manner, regardless of personnel and equipment available. The Field Artillery Target Acquisition Battalion meteorological section is used in describing team operations.

94. Organization of Six-Man Teams

The tables of organization and equipment for the headquarters and headquarters battery of the Field Artillery Target Acquisition Battalion authorize 1 warrant officer (meteorology technician) and 17 enlisted men in the met section. The met section chief as the senior enlisted member of the met section (E-7), must have a thorough knowledge of artillery ballistic meteorology. He must know the requirements of the various types of artillery units for meteorological data. He must be able to coordinate and supervise the operations of the section. He must be able to conduct instruction on all phases of the met sections' operations. To intelligently interpret radiosonde soundings, he must be familiar with synoptic weather maps and be able to recognize significant weather changes. As a noncommissioned officer, he is responsible for the state of training and general welfare of the enlisted man under his supervision. He is further responsible to the met warrant officer for the supervision of maintenance of all equipment and its proper performance as outlined in the appropriate technical manuals. For continuous operation, the met section may be divided into six-man teams; each team operating 12 hours a day. The chief of section assists the met warrant officer in supervising the 24-hour operations. The radio operators are

primarily responsible for transmitting messages. Each six-man team includes personnel to prepare and release the radiosonde and compute artillery met messages. However, during the occupation of a new position, the entire section is required. The assignments of specific duties in the six-man team are made by the met warrant officer.

95. Organization of the Met Section Into Teams

There will be occasions when one six-man team will have to be augmented with personnel from the other team in order to furnish special met data, such as fallout met message and Air Weather Service messages, in addition to the usual artillery met messages. In normal operations, the two six-man teams are further divided into smaller teams (para 96 and 97). The organization of the met section into teams will vary with the state of training of individual members of the section, the time schedule, and the number and type of met requirements. The listing of duty positions in paragraph 29a does not imply any team organization. The met warrant officer organizes the section personnel in the manner which best accomplishes the mission.

96. Temperature-Density Team

In general, the temperature-density team is responsible for assembling the rawin set, preparing the radiosonde, and evaluating the recorded data to determine the temperature and density for the met message. The team is composed of a—

- a. Radiosonde recorder operator (RO), the team leader.
- b. Temperature-density plotter (TDP).
- c. Temperature-density computer (TDC).

97. Winds Team

In general, the winds team is responsible for erecting the inflation device, inflating the balloon, preparing the balloon train, performing the reference-temperature-humidity check, making sur-

face wind observations, and evaluating the recorded data to determine the wind direction and speed for the met messages. The team is composed of a—

- a. Zone wind computer (ZWC), the team leader.
- b. Zone wind plotter (ZWP).
- c. Ballistic wind plotter (BWP).

98. Pilot Balloon Observation Team

There may be instances in which a continuous flow of met data is required which cannot be fur-

nished by electronic means; such as during occupation of a new position area or failure of ground electronic equipment. Under these circumstances, a four-man pilot balloon observation team can be organized with personnel and equipment organic to the electronic met section. Personnel of the four-man team are assigned duties as—

- a. Theodolite operator.
- b. Timer-recorder.
- c. Zone wind plotter and surface observer.
- d. Ballistic wind plotter.

Section II. SELECTION AND OCCUPATION OF POSITION

99. Tactical and Technical Considerations in Selecting the Position Area

Since the primary mission of the artillery met section is to provide meteorological data to the artillery firing units in the command, the section must be sited where it can best sound the atmosphere through which the trajectories of the artillery will pass. The section should be located within the perimeter of the command post of an artillery unit, preferably the parent unit, providing this position does not violate the principle cited above. The position must be coordinated with the area unit commander, the staff, and the next higher headquarters. Such administrative details as messing facilities, local security, and message transmission must be considered. When possible, the following minimum requirements should be met: a level area of cleared land for the main assembly and the launching site, no obstructions within a distance of 200 meters, and no objects on the horizon above an angle of 3°. In most instances, the position selected for the met section will be one which is a compromise between this ideal location and the tactical requirements (area, cover, and camouflage). The requirements for emplacing the main components of the met section are discussed in paragraph 100.

100. Emplacement of Equipment

a. *Rawin Set AN/GMD-1* (). The location of the rawin set main assembly will control the locations of the remaining components of the station. The set must be mounted on firm, level, well-drained ground to insure continuous operation with suitable angular accuracy. Downwind, there must be an area cleared of brush, shrubs, or obstructions and sufficient in size for the release of balloons. Ideally, there should be no obstructions over 3° in elevation above the horizontal in any direction. The length of the main cable (approx-

mately 62 meters) limits the distance set can be removed from the van area.

b. *Balloon Inflation and Launching Device*. The balloon inflation and launching device should be some distance downwind from the rawin set main assembly to facilitate automatic tracking of the radiosonde at release.

c. *Computing Van*. Concealment and view of the balloon launching site are the major requirements for the van. Comfort of personnel operating inside the van may be increased by considering shade and the direction of prevailing winds when the location of the truck is selected.

d. *Power Units*. The trailer containing the power units must be placed under concealment; it should be positioned where the noise of the generator will not interfere with the work of personnel in the van. The length of the power cable (46 meters) limits the distance that the power unit may be separated from the van. Access to the power unit for fueling, lubrication, and maintenance is another consideration.

e. *Baseline Check Set AN/GMM-1* (). The baseline check set is placed in a shaded location near the van and convenient for radiosonde test activities. Although local conditions will necessarily determine the site, a location near electrical machinery, high-tension power lines, and commercial telephone wires should be avoided. The conditioning chamber must be located so that it is shielded from direct or reflected rays of the sun. There should be no obstacles, such as earth or metallic objects, which would block the transmitted signal between the baseline check set and the rawin set main assembly. Baseline check procedures are facilitated by placing the control unit inside the van, where it can be operated by the radiosonde recorder operator (RO). For more detailed information, refer to TM 11-6660-219-12.

101. Survey Control

a. The area occupied by the met section must be identified, and a line of direction must be established therein. This is necessary because the location and altitude of the met station are part of the information transmitted with the met data, and wind direction must be computed with respect to true north. The specific requirements are:

(1) The location of the rawin set to within 6 minutes longitude and latitude (grid coordinates are acceptable).

(2) The height of the met datum plane (MDP) to the nearest 10 meters.

(3) A line of known direction, accurate to 0.1 degree (1.8 mils).

b. The location and altitude of the met station may be established from a large-scale map by spot inspection. If a large-scale map is not available, the location must be established by survey. Requests for survey control are sent to the corps or division artillery survey officer.

c. Direction may be established by use of the compass on the theodolite, provided the theodolite has been declinated for the area. A theodolite is declinated when the 360° line points to true north when the compass needle is centered. The preferred method of direction control is by survey. Direction control furnished by the survey officer is a grid azimuth reference and must be converted to a true azimuth reference. This conversion is accomplished by means of the grid azimuth conversion chart in FM 6-16. This chart gives the mil correction to be applied to the grid azimuth, based on the location of the grid coordinates, to obtain true azimuth.

d. Requests for survey control must be coordinated so that control will be brought to a stake in the ground at the rawin set; and direction will be provided from that stake to a distant, clearly identified reference point. Requests should specify whether geographic or grid coordinates are desired.

102. Movement to Position

Movement of the met section must be planned and organized to provide an uninterrupted flow of met data required by the artillery firing units. The unit (battalion, group, brigade) commander is responsible for directing the movement of the met section according to the tactical situation.

103. Personnel and Equipment Loading Plan

a. *Suggested Loading Plan for Artillery Met Sections.*

(1) *Truck ¾-ton, 4x4, with trailer, cargo, ¾-ton.*

Personnel

- Met officer (WO)
- Met plotter (E-3), driver
- Senior met computer
- Two met plotters
- Two met computers

Equipment

- Ax, single-bit, 4-lb, 4¾-in. cut, 36 in. handle
- Mattock, pick, 5-lb, nominal size, with 36-in. long handle
- Shovel, hand, round point, open back, D-handle, 11½-to 12½-in. blade
- Binocular, 7x50
- Compass, mil graduations
- Gun, machine, 7.62-mm
- Mount, tripod, machine gun, 7.62-mm
- Goggles, M-1944 (driver)

(2) *Truck, cargo 2½-ton, 6x6, with trailer, cargo, 1½-ton.*

Personnel

- Met plotter (E-3) driver
- Ballistic met equipment mechanic
- Chief met computer

Equipment

- Ax, single bit, 4-lb, 4¾-in. cut, 36-in. handle
- Mattock, pick, 5-lb, nominal size with 36-in. long handle
- Shovel, hand, round point, open back, D-handle, 11½-to 12½-in. blade.
- Generator set, gasoline engine, 10-kw (mtd in trailer)
- Goggles, M-1944 (driver)
- Power unit PE-75 (in trailer)
- Chain, assembly, single-leg, with pear links and grab hook

Meteorological station, manual AN/TMQ-4 components

- Can, corrugated, galvanized iron, 32-gallon (in trailer)
- Balloon inflation and launching device ML-594/U
- Charge, calcium hydride, ML-304A/TM (2 cases, 54 ea)
- Battery pack BA-259 (4 cases, 24 ea)
- Charge, calcium hydride, ML-305A/TM (25 cases, 20 ea)
- Charge, calcium hydride, ML-587/TM (20 cases, 20 ea)
- Lighting unit ML-338/AM (10 cans)
- Parachute, ML-132 (1 case, 100 ea)

Balloon ML-537 (2 cases, 48 ea)
 Balloon ML-541 (1 case, 48 ea)
 Radiosonde AN/AMT-4() (4 cases, 24 ea)

(3) *Truck 2½-ton, cargo, 6x6, with trailer, water 1½-ton.*

Personnel

Met computer (E-4), driver
 Met section chief (E-6)
 Radiosonde operator

Equipment

AX, single-bit, 4-lb, 4¾-in. cut, 36-in. handle
 Mattock, pick, 5-lb, nominal size with 36-in. handle
 Shovel, hand, round point, open back, D-handle, 11½-to 12½-in. blade
 Goggles, M-1944 (driver)
 Heater, water, immersion, gas-operated
 Chain assembly, single-leg, with pear links and grab hook

Meteorological station, manual AN/TMQ-4 components

Hydrogen generator set AN/TMQ-3 (2 ea)
 Ground rod (4 ea)
 Clamp, electrical (6 ea)
 Bracket assembly, antibouyancy (1 ea)
 Charge, calcium hydride, ML-305A/TM (25 cases, 20 ea)
 Charge, calcium hydride, ML-587/TM (20 cases, 20 ea)
 Battery pack BA-259 (4 cases, 24 ea)
 Charge, calcium hydride, ML-304/TM (2 cases, 54 ea)
 Launching reel ML-367/AM (1 case, 48 ea)
 Parachute ML-132 (1 case, 100 ea)
 Balloon M-537 (1 case, 48 ea)
 Balloon ML-541 (1 case, 48 ea)
 Radiosonde AN/AMT-4() (4 cases, 24 ea)

(4) *Truck, van shop, 2½-ton, 6x6, with trailer, cargo, 1½-ton.*

Personnel

Met computer (E-4), driver
 Met section chief (E-7)

Equipment

Ax, single-bit, 4-lb. 4¾-in. cut, 36-in. handle
 Mattock, pick, 5-lb, nominal size with 36-in. handle
 Shovel, hand, round point, open back, D-handle, 11½- to 12½-in. blade
 Binocular, 7x50
 Compass, mil graduations

Barometer, ML-333/TM
 Watch, stop, type B
 Case, field, office machine
 Chair, folding (2)
 Cook set, field
 Clock, message center
 Goggles, M-1944 (driver)
 Stove, gasoline, 1-burner
 Table, folding legs, wood (2)
 Typewriter, portable, elite with case
 Dynamic loudspeaker LS-166/U
 Frequency standard TS-65/FMQ-1
 Handset-headset H-144/U (2)
 Multimeter TS-352/U
 Radiosonde baseline check set AN/GMM-1
 Radiosonde recorder AN/TMQ-5
 Rawin set AN/GMD-1 (trailer-loaded)
 Support, radiosonde recorder, MT-1355/TMQ-5
 Test set, electron tube, TV-7/U
 Thermometer ML-352/UM
 Tool kit, radio and radar
 Chain, assembly, single leg, with pear links and grab hook

Meteorological station, manual AN/TMQ-4 components

Reel RL-39()
 Coupling ML-49
 Wrench TL-112
 Tool equipment TE-33
 Telephone set TA-312/PT
 Head and chest set HS-25C (2)
 Wire, WD-1/TT, 400 meters
 Psychrometer ML-244 (4)
 Nozzle ML-373/GM (2)
 Jack JK-54 (2)
 Pressure Time Chart, DA Form 6-49
 Chart ML-574/UM
 Thermometer and tubes (4)
 Scale ML-573/UM (2)
 Board, plotting, ML-122 (2)
 Anemometer ML-433/PM
 Nozzle, balloon, ML-196 (2)
 Straightedge ML-357/GM (2)
 Tripod ML-1309/GM (1)
 Theodolite ML-474/GM, with case
 Scale, plotting, ML-577/UM (2)
 Barometer ML-102-()
 Hydrogen regulator ML-193 (ML-528/GM)
 Sharpener, pencil
 Rule, slide (2)
 Timer, clock, FM-19
 Twine, RP-15 (20 rolls)
 Battery pack BA-259 (1 case, 24 ea)

Balloon ML-51A (1 box, 40 ea)
 Parachute ML-430/U (150)
 Balloon ML-161A (1 box, 10 ea)
 Battery pack BA-259 (1 case, 48 ea)
 Lighting unit ML-338/AM (10 cans, 6 ea)
 Balloon ML-537 (1 case, 48 ea)
 Radiosonde AN/AMT-4 () (1 case, 24 ea)
 Balloon ML-159A (4 boxes, 10 ea)
 Balloon ML-160A (1 box, 10 ea)
 Balloon ML-50A (6 boxes, 20 ea)
 Balloon ML-64A (2 boxes, 20 ea)
 Blank forms
 Necessary plotting and supply manuals

(5) *Truck, 3/4-ton, 4x4, with trailer, cargo 3/4-ton.*

Personnel

Radio TT Team Chief
 Radio TT Operator (driver)
 Radio TT Operator

Equipment

Ax, single bit, 4-lb, 4³/₄-in. cut, 36-in. handle
 Mattock, pick, 5-lb, nominal size, 36-in. handle
 Shovel, hand, round point, open back, D-handle, 11¹/₂- to 12¹/₂-in. blade
 Radio teletypewriter set AN/GRC-142
 Generator set, gas engine, 3-kw, DC 28 volts, skid-mtd (in trailer)

d. Modifications. Often it is expedient for the artillery met section to modify the loading plan by loading the control-recorder and power cable for the rawin set in the van, since these items are used in the van area. Fragile items of equipment must be protected from possible damage which may be caused by road shock of the falling or the crushing action of other equipment. A detailed loading plan should be prepared for each vehicle and kept with the vehicle, so that loading will be uniform and complete from day to day. The entire loading arrangement should be inspected periodically by the meteorological officer or chief of section.

104. Duties of Personnel During Occupation of Position

★*a. Meteorological Officer.* The meteorological officer (WO) is charged with the responsibility of detailed reconnaissance of the area and supervision of the occupation of position and installation and checking of the equipment. He leads his section to the area assigned by the unit commander. With his chief of section, he conducts a detailed ground reconnaissance and select posi-

tions for the main items of equipment, sanitation facilities, and local security. He selects a reference point and determines the met station location and altitude from map or survey data. After the electronic equipment is installed, he checks the orientation of the rawin set, inspects the grounding of the inflation equipment, verifies the voltage and frequency output of the generator, and checks the linear calibration of the radiosonde recorder AN/TMQ-5. As soon as practicable, he contacts the supported units, reports his location, and ascertains meteorological requirements (if not previously known).

b. Met Section Chief. The met section chief assists the met officer during the occupation of position. In the absence of survey data, the met section chief sets up the theodolite and measures the significant angular data to the reference point for orientation of the rawin set.

c. Temperature-Density Team. After the met section chief has located the survey stake or oriented the theodolite in the new position, the rawin trailer is towed to the desired location and uncoupled. (The trailer may affect the magnetic field if it is moved into position before the theodolite is oriented.) The van should immediately be moved to its location by the chief of section. The van should be connected to the power source as soon as possible so that operation of the electronic equipment can begin. Assembly, cabling, and orientation of the rawin set is performed immediately by members of the temperature-density team. Immediately after installation of the rawin set, the trailer is moved to an area of concealment. When power is available, the recorder operator should connect the radiosonde recorder and perform the preliminary checks and calibration. The baseline check set is then assembled and cabled in preparation for the preflight calibration of the radiosonde. The equipment is camouflaged as outlined in FM 5-20. The team on duty then moves to the van area to organize the working positions and lay out the forms, tables, and required equipment.

d. Winds Team. While the temperature-density team performs its work, the winds team works independently on its portion of the occupation. The inflation equipment is unloaded, and the water trailer is uncoupled at the inflation site. At the same time, the met equipment mechanic leads the truck towing the power generator to its selected site. The area around the power generator should be cleared as a firebreak. A gasoline storage pit is dug. The generator is then grounded,

started, and the cables are connected. The inflation device is erected, and all hydrogen generating equipment is installed and grounded. The met equipment mechanic personally inspects and tests the installation of the grounding equipment. The

final steps are the storage of expendable inflation supplies and the camouflage of the installation as outlined in FM 5-20. The winds team on duty then moves the van area to lay out the necessary forms, tables, and plotting equipment.

Section III. TEAM DUTIES BEFORE BALLOON RELEASE

105. The Section Chief

The met section chief insures that all equipment is in good operating condition and adequately serviced. Special attention must be paid to the power units to insure continuous power during a flight. He determines the amount of total lift of the balloon (para 66). The section chief should personally verify the validity of the baseline check of the radiosonde. He positions the rawin set before making the baseline check and verifies orientation. A standing operating procedure which lists in detail the specific duties of each team member during all stages of the flight will enable the station chief to spend more time supervising the section.

106. Duties of the Temperature-Density Team

a. Unpacking Radiosondes. When possible, radiosondes should be stored indoors in their original cartons. The storage space should be dry and not subject to extreme temperatures. The cartons are dated and should be arranged so that the older radiosondes are used first. Individual radiosonde packages should not be opened more than 12 hours before use. Temperature and humidity elements should never be opened until time for final assembly of the radiosonde. The water and vapor proof containers and wrappings must be removed carefully to avoid damage to delicate parts. For further information regarding storage, assembly, and use, see TM 11-2432A and TM 11-6660-220-10.

b. Visual Inspection of Radiosondes. The element container is removed from the battery compartment. The baroswitch serial number on the calibration chart is checked to insure that it agrees with the serial number on the baroswitch or hypsometer. (Examples of calibration charts are shown in fig. 60.) The instrument is rejected if these serial numbers do not agree. Each baroswitch and hypsometer is individually calibrated, and the correct chart must be used. The elements are inspected to insure that they are present and in usable condition. The overall condition of the modulator and wiring is inspected, and defective units are rejected. The transmitter is inspected

for damage to the case, wire, and plug. The following seven points should be checked:

(1) The linkage connecting the aneroid cell(s) to the pin arm is checked for the presence of corrosion. The modulator is rejected if corrosion exists.

(2) The commutator bar is examined for corrosion. If the bar is corroded, it should be rubbed with lens tissue.

Caution: Be sure to rub the bar in a direction parallel to the conducting segments.

(3) The element clips are cleaned of corrosion with abrasive paper.

(4) The hypsometer is visually inspected, without removing it from the modulator.

(5) With the pin arm on the commutator bar, the radiosonde is inverted. If the pin arm falls away from the commutator bar, the modulator is rejected.

(6) The pin arm is moved, with the finger, one contact in the direction of decreasing pressure and released. If it does not spring back to its original position, the modulator is rejected.

(7) The correct setting of the pin arm is determined from a barometric reading and the modulator calibration chart. If the pin arm position is not within 2.0 contacts of the correct setting, the modulator is rejected.

c. Commutator Bar and Pin Arm Setting. The pressure calibration chart packed with each radiosonde modulator reflects the relationship between air pressure and the position of the pin arm on the commutator bar. This calibration chart is prepared by the manufacturer for each individual modulator and is based on the movement of the pin arm across the commutator bar as the air pressure is decreased inside a vacuum chamber. However, the position of the pin arm relative to the commutator bar may be changed during transit and storage. For this reason, the met section must adjust the pin arm to the position that corresponds to the ambient air pressure. The adjustment is performed after baseline check. The procedure for positioning the commutator bar relative to the pin arm is as follows:

(1) Commutator adjustment by sound method follows:

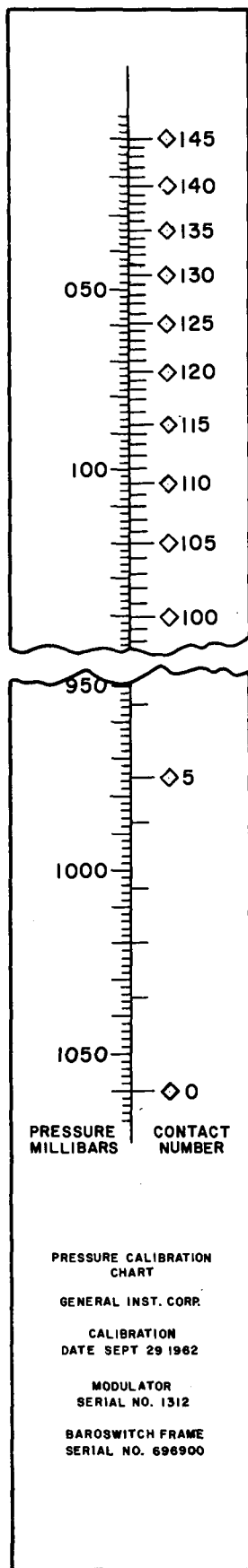

Figure 60. Pressure calibration chart.

(a) Determine the station pressure, in millibars, from the barometer.

★(b) Enter the pressure calibration chart with the station pressure as the argument and determine the correct contact number to the nearest 0.1 contact. This contact number refers to the relative position of the pin arm on the commutator bar.

★(c) Identify the audio sound heard at the speaker of the radiosonde recorder with either temperature, humidity, or reference by crossing the wires on the modulator. (If the Signal Selector Switch is set in the signal position and the Power Switch is set in the stand-by position, the relative positions of these signals, on the chart, can be observed.)

(d) The audio tone heard will indicate whether the pin arm is on a conducting segment (reference or humidity) or an insulating segment (temperature). For example, if the correct contact number is 5.4 the pin arm must be set between 5.0 (reference) and 6.0 (humidity). Once this position is confirmed, adjust the commutator bar adjusting screw so that the pin arm is at the beginning of 5.0 and a reference tone is heard.

(e) Lower the pin arm onto the commutator bar.

(f) Turn the commutator bar adjusting screw to position the commutator toward lower pressure so that the pin arm is on the beginning of the next higher contact number (6.0). The operator counts the number of clicks as he turns the adjusting screw. The reference tone is heard as the movement of the commutator bar begins (5.0) and then changes as the pin arm position leaves the conducting segment, and the temperature tone is heard until the next conducting segment is reached (humidity 6.0). The total number of clicks counted during this movement represents the width of the correct contact, the fifth contact in this example.

(g) The position of the pin arm within the correct contact is determined by multiplying the number of clicks in the width of the contact by the decimal portion of the correct contact number. The commutator bar is then returned to the beginning of the contact just counted and advanced, toward lower pressure, the number of clicks computed.

(h) For example, the calibration chart in figure 60 shows that the correct position of the pin arm of the modulator is 5.4 contact for a

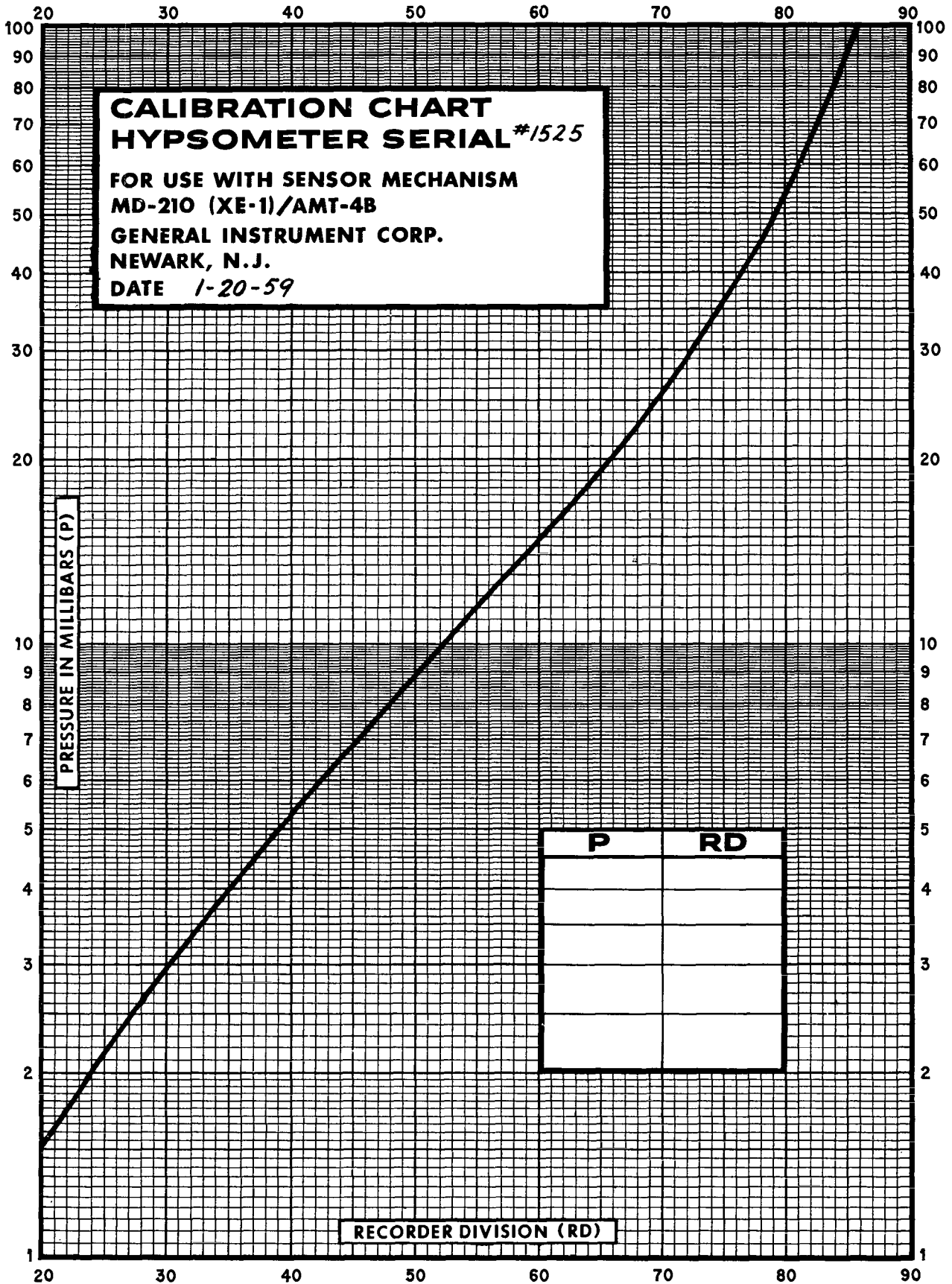

Figure 60—Continued.

pressure of 967 mb. The operator's visual inspection shows the pin arm to be about halfway between the fifth and sixth contacts. Move the pin arm position to the beginning of the fifth contact by turning the commutator bar adjusting screw. The reference tone will be heard when the pin arm reaches the conducting segment and will continue until the tone changes. This point is 5.0 contacts. Then turn the adjusting screw counterclockwise, moving the pin arm position across the reference segments. The tone will change as the pin arm position moves from the conducting segment to the insulating segment (temperature). The number of clicks from 5.0 to 6.0 contacts is 24. Four-tenths of 24 clicks is 10 clicks. The operator then returns the pin arm to 5.0 and advances the pin arm position 10 clicks into the fifth contact. The pin arm is now positioned at 5.4 contacts.

(2) An alternate method for adjusting the commutator is the use of the baseline check set and is referred to as the light method; this method is described in TM 11-6660-219-12.

107. Preparation of Battery Pack BA-259/AM

a. Description. Battery pack BA-259/AM is a water activated battery which supplies the power required to operate the radiosonde. The average time required for the battery to be activated and achieve full power is 20 minutes. The life of the battery is about 4 hours.

b. Preparation. Instructions for activating the battery are printed on the battery cover. Different manufacturers prescribe slightly different procedures for activating the battery.

108. Assembly and Electrical Test of the Radiosonde

a. General. The assembly of the radiosonde should be scheduled according to the required time of release. Assembly far in advance of the time of release is to be avoided. A time interval of 20 minutes is allowed for activation of the battery and production of full power. Another time interval of 15 minutes is allowed for performance of the baseline check. These time intervals are approximate. Experience will indicate the amount of time required to assemble the radiosonde under varying conditions encountered in the field.

b. Procedure. After activation, the battery is placed on the battery shelf of the baseline check set and connected to the plug provided. The bat-

tery should always be placed with the top of the battery up. Next, the transmitter is attached to the modulator and the electrical connection is made between the battery and the radiosonde. A minimum of 10 minutes is required for the battery to attain sufficient operating power. The purpose of this step is to permit performance of the electrical tests of the radiosonde prior to the installation of the sensing elements. After the battery has built up to sufficient operating power, the rawin receiver is tuned to receive the frequency being transmitted by the radiosonde. The SIGNAL SELECTOR switch of the radiosonde recorder is positioned to the SIGNAL position, and the RECORDS CONTROL switch on the control-recorder is positioned to the BASELINE position. With no elements installed on the radiosonde, no audio tone or pen movement should be present at the radiosonde recorder at this time. If an audio tone or pen movement is present at this time, electrical leakage is present in the modulator and the modulator should be rejected. Next, place two fingers in contact with the temperature element clips. The pen should depart from the zero position and an audio tone should be heard from the speaker indicating proper functioning of the temperature circuit. If no pen movement occurs and no audio tone is heard, reject the modulator. Next, cross the black and yellow test leads. The relay in the modulator should be heard closing. The pen should depart from the zero position and move to about five recorder divisions on the chart and a put-put audio tone should be heard from the speaker. If no pen movement occurs and no audio tone is heard, reject the modulator. Next, the blue and black leads are crossed. The pen should depart from the zero position and travel to about 95 divisions on the recorder record and a high-pitched audio tone should be heard from the speaker, indicating proper functioning of the reference circuit. If no pen movement occurs and no audio tone is heard, reject the modulator. If all three circuits fail to cause pen movement or audio tone, the probable cause is in the transmitter and not in the modulator. After the electrical test has been completed, insuring a properly functioning radiosonde, the electrical connection between the radiosonde and battery is disconnected. The radiosonde is removed from the baseline check set, and the sensing elements are installed. The humidity element is installed first and then the temperature element. Prior to installing the humidity element the excess carbon is removed from the electrodes by lightly scraping with a pocket knife or a suitable item. Scraping the electrodes

insures better contact between the element and the element clips. To install the humidity element, the humidity element cover is raised and the element is inserted into the element clips. To install the temperature element, the temperature element arms are raised and locked in an extended position. The element leads should be clamped in the rough portion of the clips, with the element centered between the clips. About half the lead wires are left free of the clips and twisted around the element clips to further secure the temperature element. The leads are bent so that the temperature element extends away from the modulator. When the radiosonde is released, the temperature element should be in the opposite direction from the balloon train so that it will not be broken. Immediately after the installation of the elements, the radiosonde is placed in the baseline check set, which has been prepared as described in paragraph 89*b* and *c*, and the electrical connection is made between the radiosonde and battery. Then the chamber door is closed and the POWER and FAN switches on the baseline control unit are turned to the ON position. During the entire assembly of the radiosonde, the pin arm should be in the OFF position. While the conditions inside the baseline check set are stabilizing, the power output check and the frequency check are performed.

Caution: Be careful to handle the humidity element by the edges and the temperature element by the lead wires when installing the elements in the modulator. Reject broken, chipped, scratched, or fingerprinted elements.

109. Power Output Check and Frequency Setting Using Test Set TS-538/U

a. Use of Test Set TS-538/U in Checking Radiosonde Power Output. A small antenna is carried under the removable cover of test set TS-538/U. For use, it is firmly screwed in place in the socket on top of the set. The test set is oriented so that the antenna is parallel to the radiosonde transmitter antenna. Ordinarily, the test set is positioned as shown in figure 61. As the test set is moved close to the radiosonde transmitter, the needle on the meter of the test set will deflect. The power output of the radiosonde is satisfactory if the needle deflects into the GOOD (green) portion of the dial while the antenna and the transmitter are 8 to 12 inches apart. If the antenna and transmitter are too close, excess power may cause the meter needle to deflect off the scale and may possibly damage the test set.

b. Use of Test Set TS-538/U in adjusting Radiosonde Frequency. After the power output of the radiosonde is determined to be satisfactory, the test set is positioned so that the meter needle indicates about two-thirds of the scale. The FREQUENCY METER dial is then rotated until the meter needle dips to the left and quickly returns to its previous position. This dip is sometimes very slight and difficult to detect, since the slightest movement of the test set or the radiosonde transmitter will also cause the needle to deflect. After the dip is observed, the FREQUENCY METER dial is adjusted until the meter needle indicates the lowest point of the dip. At this point, the reading on the FREQUENCY METER dial indicates the frequency of the carrier wave being transmitted. If this frequency is not the desired carrier frequency, an appropriate adjustment is made, using the frequency adjusting screw(s) on the radiosonde transmitter. An arrow on the transmitter case indicates the direction in which the frequency adjusting screw(s) must be turned to raise the frequency. The screw(s) is adjusted until the desired frequency is read on the FREQUENCY METER dial. The radiosonde recorder operator may now proceed with the baseline check.

Note. After the baseline check is completed and before the radiosonde is removed from the baseline check set, another frequency check is made with the test set to insure that the radiosonde transmitter is properly set on the desired frequency.

110. Baseline Check of Radiosonde and Sensing Elements

The radiosonde recorder record consists of a series of traces representing the values of temperature, relative humidity, and pressure at selected points in the atmosphere. Values of temperature and relative humidity are represented by the positions of the respective traces across the record as measured in recorder divisions. Thus, in order to obtain the temperatures in degrees Celsius and the relative humidities in percent, the value of the relationship between the recorder record divisions and each of these elements must be established. The two relationships are determined by the baseline check set AN/GMM-1() and computer, humidity-temperature, CP-223B/UM. By means of the baseline check set, the known conditions of temperature and relative humidity are measured by the radiosonde. These radiosonde measurements are printed as recorder divisions on the recorder record. These recorder divisions

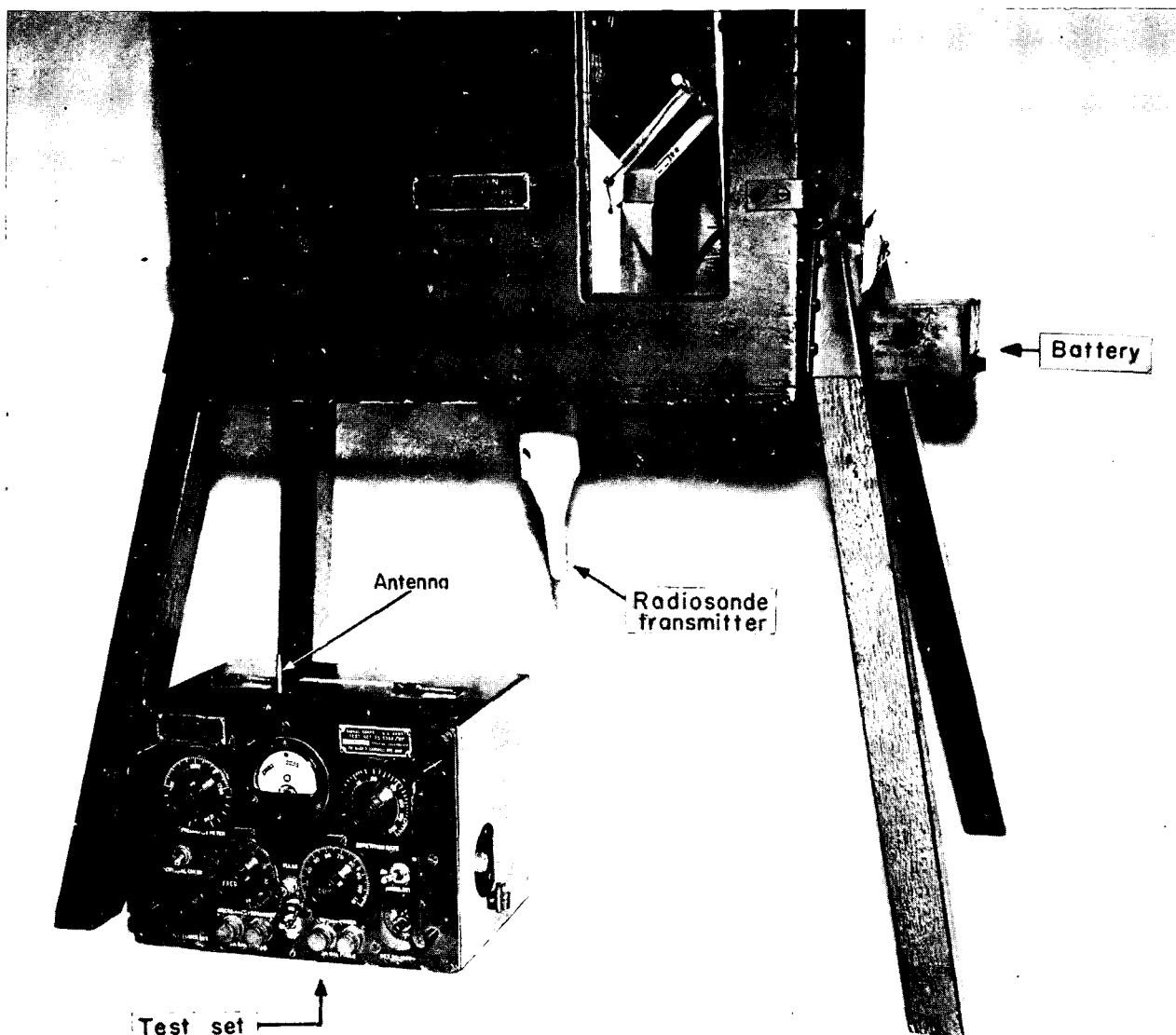

Figure 61. Position of test set for frequency setting and power check.

are then compared with the measured values of temperature and relative humidity by means of the humidity-temperature computer. The measured values are obtained from the psychrometer within the baseline check set and from chart VIII in FM 6-16. Before any comparisons are made, the characteristics of the air inside the check set must be stable (i.e., the radiosonde elements must be sensing the same air sample as the psychrometer). The requirements for obtaining stable air inside the check set are listed in *i* below. The baseline check is performed as follows:

a. While the power output and the frequency of the radiosonde transmitter are being checked,

the rawin set is pointed in the general direction of the radiosonde. Then the rawin set is tuned to the radiosonde carrier frequency so that the received signal indicates a strength of 60 or more microamperes on the TUNING METER. Values lower than this will be obtained until the power output of the battery reaches its operational level.

b. After the rawin set is tuned, the automatic tracking feature of the rawin set is checked. The antenna assembly is manually positioned to a point a few degrees above and to the side of the radiosonde. Then the MANUAL-NEAR AUTO-FAR AUTO control on the antenna control panel (⊙, fig. 50) is turned to the NEAR AUTO posi-

tion. If the rawin set is tracking properly, it will automatically position itself on the radiosonde. This check is repeated several times to insure that the set is tracking automatically in both azimuth and elevation. If the set will not track automatically, the fault must be corrected before the radiosonde is released.

c. When the automatic tracking check has been performed, the rawin set antenna is manually positioned toward the baseline check set. Normally, in this position the antenna is directed about 20° above the radiosonde in order to minimize the effect of ground-reflected waves and to lessen the signal strength. Either ground-reflected waves or an excessive signal strength may cause an erratic tracing by the radiosonde recorder pen. Erratic pen tracing may also be caused by motor ignition, radio transmitters, or movement of personnel in the area of the rawin set and the radiosonde.

d. After the rawin set is directed toward the baseline check set, the MOTORS-STANDBY switch is placed in the STANDBY position. The switch is left in this position throughout the baseline check, as operation of the motors may result in fluctuation of the recorder pen.

e. The met signal is received at the radiosonde recorder by placing the SIGNAL SELECTOR switch on the radiosonde recorder in the SIG position and placing the RECORDS CONTROL switch on the control-recorder (fig. 51) in the BASELINE CHECK position. Prior to this, the radiosonde recorder should have been calibrated and prepared for operation as described in chapter 6.

f. Prior to performing the baseline check, the following test should be performed as a partial check for poor electrical contact at the terminal strip of the baseline check set:

(1) Cause the radiosonde to transmit low reference signal by shorting the black and the blue test leads. Adjust the low reference printed by the radiosonde recorder to 95.0 recorder divisions.

(2) Place the test leads into the baseline check set terminal strip and set the SELECTOR switch of the baseline check set control unit to REFERENCE. The radiosonde recorder pen should print within 0.5 recorder divisions of the 95th recorder division. If this condition exists, the baseline check may be performed; otherwise, clean the terminals on the terminal strip and the radiosonde test leads and repeat the test.

g. Recommended limits within the temperature-humidity chamber for baseline check are 28 to 50 percent relative humidity and a temperature of 0° C. or higher. Every *reasonable* effort should be made to obtain baseline check conditions within these limits. The battery is always installed on the pullout shelf on the right side of the chamber when using Humidity Element ML-476/AMT; power is connected to the radiosonde through the socket on the chamber wall. If the relative humidity is over 50 percent, approximately 4 ounces of dry calcium chloride should be placed in the tray inside the chamber to reduce the humidity. Additional calcium chloride should be used if necessary to bring the relative humidity within the chamber to 50 percent or less. If the relative humidity is less than 28 percent, the tray inside the conditioning chamber should be filled about three-quarters full with water to raise the humidity.

h. The temperature and humidity reference traces are identified and marked (6, fig. 62) on the recorder record by switching the baseline check set SELECTOR switch to the TEMPERATURE and HUMIDITY positions. After the traces are located on the record, the SELECTOR switch is turned to AUTOMATIC. In this position, the baseline check set will continuously switch the transmitted signal through the following cycle of traces, each trace being 15 seconds in duration: reference, temperature, reference, humidity. Each reference trace that is printed is adjusted to exactly 95.0 recorder divisions (8, fig. 62) with the REF ADJUST handwheel, if necessary (1, fig. 62).

★i. The recorder operator observes the position of each trace. Four successive traces of reference, two successive traces of temperature and two successive traces of humidity that do not deviate from a trend by more than three tenths of a recorder division are required to be recorded. When this condition has been met, the baseline check is then terminated utilizing temperature as a final recorded trace.

j. After 10 minutes, if the successive traces of temperature and humidity are not being printed within the prescribed criteria, and conditions in the baseline check set chamber may not be stable. To obtain stability, the following actions may be taken: Make certain that the fan is operating. Be sure the baseline check set is out of the direct rays of the sun. If the temperature and humidity traces still are not being printed within the prescribed criteria, new temperature and/or humid-

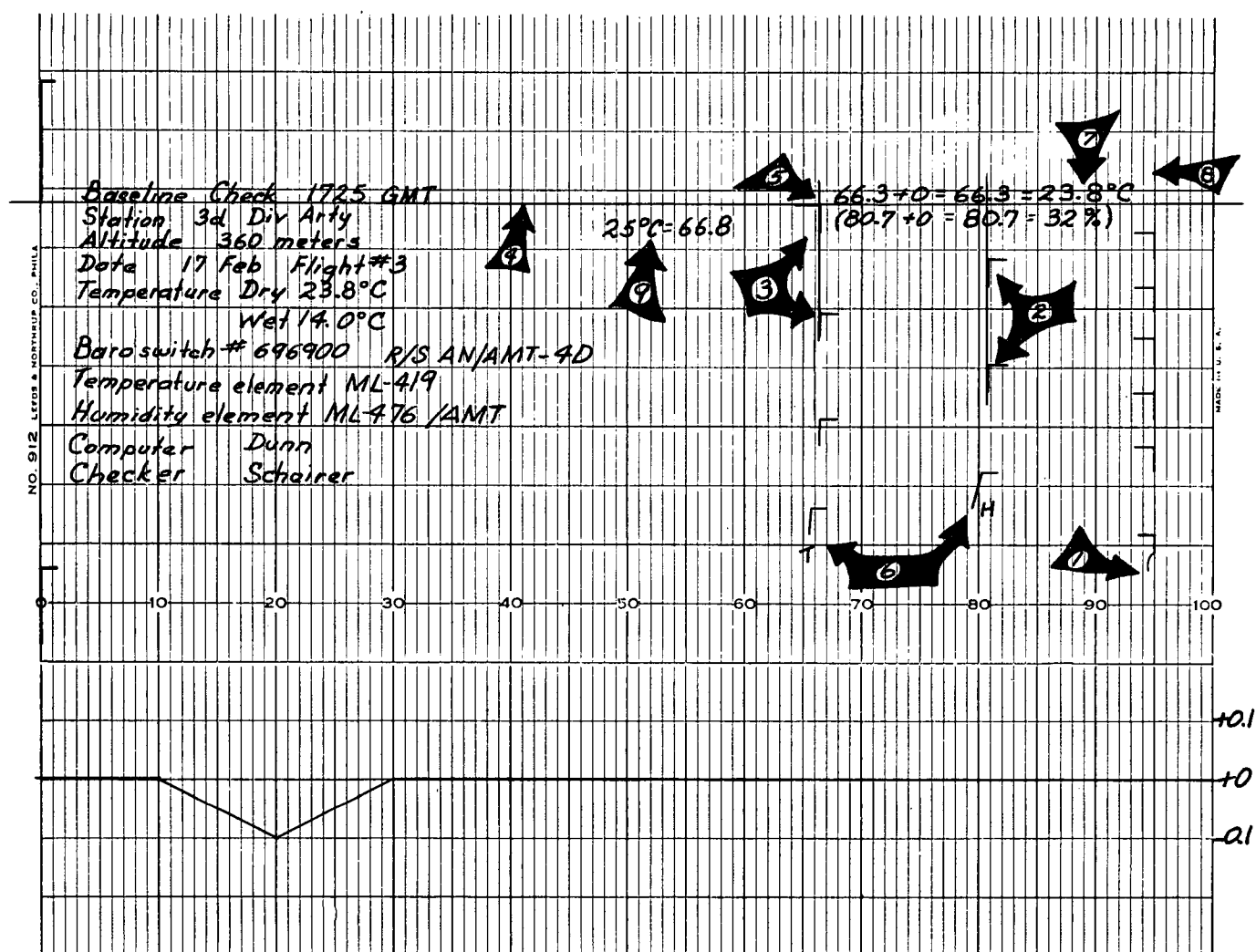

Figure 62. An evaluated baseline check.

ity elements are installed and a new baseline check is performed. If the reference traces fail to meet the prescribed criteria, immediately inform the maintenance technician.

k. When the requirements for a baseline check are met, the check is terminated on a temperature trace. The SIGNAL SELECTOR switch is placed in the SC position. At the same time, the psychrometer inside the chamber is read—first, the wet bulb temperature, then the dry-bulb temperature. These temperatures are read carefully to the nearest 0.1° C. and entered on the radiosonde recorder record and the radiosonde data sheet. The SIGNAL SELECTOR switch remains in the SC position until the zero print has recorded for a minimum of 1 inch to insure that no chart drifts exists. The POWER ON-POWER OFF-STANDBY switch is placed in STAND BY position, and the chart is advanced manually to the evaluation desk.

l. The radiosonde is left in the baseline check set atmosphere chamber until the validity of the baseline check is determined. The baseline check is verified as quickly as possible by the section chief and the radiosonde recorder operator. If the baseline check is valid, the baseline check set SELECTOR switch is set to the TEMPERATURE position and the POWER, FAN, HEATER, and LIGHT switches are turned off. If the baseline check is not valid, new temperature and/or humidity elements are installed and a new baseline check is performed.

111. Evaluation of the Baseline Check

In figure 62, low reference traces 1, relative humidity traces 2, and temperature traces 3 are shown. The first step in evaluating the baseline check is to establish a baseline 4. The baseline 4 is a horizontal line drawn across the record through the top of the last temperature trace.

The next step is to evaluate the temperature trace. A thin straight line 5 is drawn through the top left corners of the last two temperature traces and extended about one-fourth inch above the baseline. The recorder division value corresponding to the point of intersection of the line drawn through the temperature traces and the baseline is evaluated to the nearest 0.1 recorder division. The ordinate value of temperature, the calibration correction, the algebraic sum of the temperature ordinate and the calibration correction, and the dry-bulb temperature inside the baseline check set are recorded above the baseline as shown by 7 in figure 62. Humidity is evaluated in the same manner as temperature, but the values are entered below the baseline and enclosed in parenthesis. In addition, the corrected recorder divisions for humidity are equated to the percentage of relative humidity determined from the wet- and dry-bulb temperatures and the relative humidity chart in FM 6-16. The recording of 25° C. and its equivalent in recorder divisions is placed below the baseline in the center of the chart as a verification of a valid baseline (9, fig 62). The last step in evaluating the baseline check is to record the baseline check items on the lefthand side of the record with the first item above the baseline and the others below it. The 11 items, in sequence, are—

a. The words "baseline check" and the time (GMT) of the last trace (above the baseline).

b. The designation of the station (just below the baseline).

c. The station altitude in meters.

d. The date of the flight (GMT) and the flight number.

e. The dry-bulb temperature to the nearest 0.1° C. as read inside the baseline check set at the time the baseline check is terminated.

f. The wet-bulb temperature determined at the same time as the dry-bulb temperature (e above).

g. The baroswitch serial number and the type of radiosonde.

h. The type of temperature element installed in the radiosonde.

i. The type of humidity element installed in the radiosonde.

j. The name of the computer (radiosonde recorder operator).

k. The name of the checker (temperature-density plotter).

112. Humidity-Temperature Computer

a. *Functions.* The humidity-temperature computer CP-223B/UM (fig 63) is used to determine

the validity of the baseline check and to convert the recorder divisions of temperature into degrees Celsius and the recorder divisions of relative humidity into percentages.

b. *Description.* The computer is a circular slide rule consisting of three concentric plastic disks fastened together at their centers with a common screw and two knurled knobs so that each disk rotates independently. Also on the same center is a transparent arm (cursor) with a hairline engraved on its long axis. The hairline is used to align the graduations of one disk with those of another. The cursor is graduated in degrees Celsius. The largest disk (base plate) is inscribed with the temperature scale. The middle disk is graduated in units representing frequency in recorder divisions. The smallest disk (humidity plate) consists of a family of curves representing the percent of relative humidity.

c. *Establishing the Temperature-Recorder Division Equivalency.* The temperature-recorder division equivalency is set on the computer by positioning the hairline of the cursor over the baseline check set dry-bulb temperature to the nearest 0.1° C. on the temperature scale (base plate). With the cursor held firmly in place, the recorder division plate is rotated until the correct recorder division value of the baseline temperature, to the nearest 0.1 recorder division, falls under the hairline. The smaller knurled knob is firmly tightened, and the larger knurled knob is loosened one-half turn. These steps complete the setting of the temperature equivalency.

d. *Establishing the Humidity-Recorder Division Equivalency.* The humidity-recorder division equivalency is established by rotating the cursor to position the hairline directly over the corrected baseline check value of humidity recorder divisions on the recorder division plate. The humidity plate is then rotated with the cursor held in place until the baseline check percentage of relative humidity is directly under the point corresponding to the dry-bulb temperature. The baseline humidity should be visually interpolated to the nearest percent on the humidity plate. The larger knurled knob is tightened firmly.

e. *Conversion of Temperature-Recorder Division Value to Degrees Celsius.* The temperature-recorder division value is converted to degrees Celsius by positioning the cursor hairline over the recorder division value on the recorder division plate and reading the temperature to the nearest 0.1° C. under the cursor hairline.

f. *Conversion of Humidity-Recorder Division Values to Percent of Relative Humidity.* The hu-

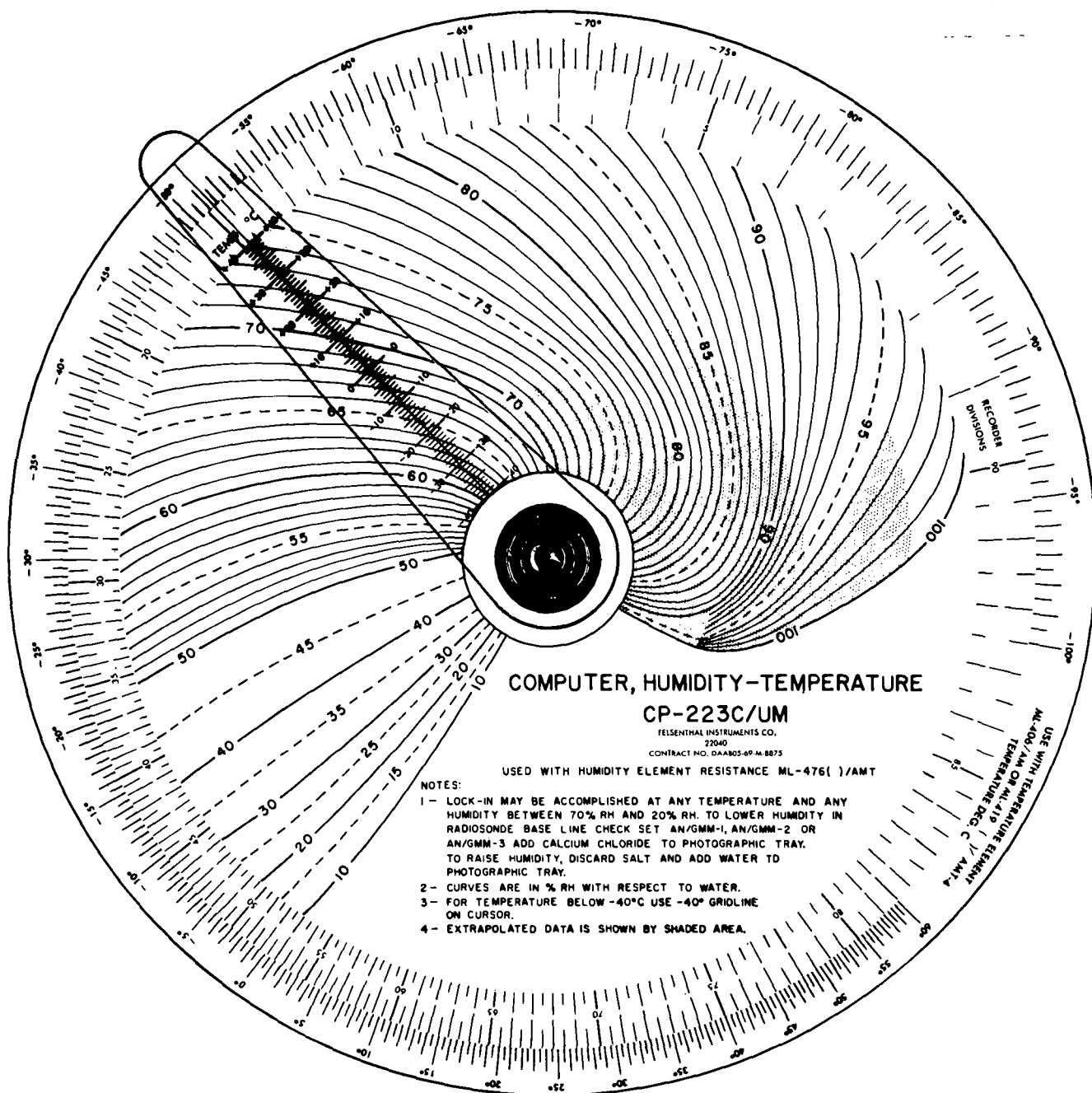

★Figure 63. Computer, humidity-temperature, CP-223C/UM.

midity-recorder division value is converted to percent of relative humidity by positioning the cursor hairline over the recorder division value and locating on the hairline the temperature at which the humidity measurement took place. The percent of relative humidity is read under this point on the humidity plate. Humidity is read to the nearest whole percent by interpolating between the printed curves. A complete set of instructions is printed on the computer.

113. Determining Validity of Baseline Check

★The baseline will be considered valid if the following requirements are met. After the humidity-temperature computer CP-223C/UM has been set with the baseline check data, the 25° C. graduation on the base plate should be compared with the corresponding recorder division value on the recorder division plate. If the 25° C. graduation falls between 66.5 and 68.9 recorder divisions, the

temperature element is good (fig. 63). If the 25° C. graduation is outside these limits, the temperature element should be replaced and another baseline check performed.

114. Final Check of Radiosonde and Receiving Equipment

After the validity of the baseline check has been determined, the frequency of the radiosonde is rechecked with the test set TS-538/U and the radiosonde is removed from the conditioning chamber for final preparations.

a. Installation of Battery. The battery is removed from the pullout shelf of the conditioning chamber and installed in the radiosonde.

b. Check of Signal Strength. After the battery has been installed, the radiosonde signal strength should be rechecked. The rawin set antenna assembly is pointed in the general direction of the radiosonde and the signal strength is noted at the rawin set. There should be a reading of 60 or more microamperes on the TUNING METER.

c. Rechecking of Pin Arm Setting. The pin arm of the radiosonde is rechecked to insure that its position in regard to contact number, corresponds to the surface pressure read from the barometer.

d. Exposure of the Radiosonde. When the temperature within the baseline check set differs drastically from the actual surface temperature, a short exposure of the radiosonde to outside conditions may be necessary before the reference-temperature-humidity check is performed.

e. Automatic Tracking. As the radiosonde is carried to the inflation tent, the automatic tracking of the rawin set is rechecked.

★*f. Reference-Temperature-Humidity Check.* The radiosonde recorder operator positions the SIGNAL SELECTOR switch to the SIG position and the POWER ON-POWER OFF-STAND BY switch from STAND BY to POWER ON position. After the signal strength check has been completed, a check of reference, temperature, and humidity is made. There are two purposes for performing this check. The first is to align the pen of the radiosonde recorder on the 95th recorder division of the recorder record while a low reference signal is transmitted from the radiosonde. The second is to obtain the values of temperature and relative humidity at surface. These checks (2, fig. 74) are made just prior to release of the radiosonde. To perform these

checks, the radiosonde is taken to the release area and held by the modulator away from the body of the operator at approximately six feet above the ground. To make the low reference check, connect the blue and black test leads on the outside of the modulator (pin arm up), and permit a short trace to print on the radiosonde recorder record. With the REF-ADJUST hand-wheel, adjust the pen of the recorder so that low reference prints at 95.0 recorder division. This adjustment reasonably insures that the first low reference trace after release will print at 95.0 recorder divisions and minimize frequency drift. To make the temperature check, open the leads that were crossed to obtain a reference signal and allow a short temperature trace to print on the radiosonde recorder record. To make the humidity check, cross the yellow and black test leads on the modulator and allow a short trace to print on the radiosonde recorder record. The temperature trace is evaluated to the nearest 0.1° C. and the humidity trace is evaluated to the nearest percent relative humidity by use of the humidity-temperature computer CP 223C/UM. These values of temperature and relative humidity are used as surface data.

g. Clip Leads. The radiosonde test leads should be clipped off to prevent shorting.

h. Lowering the Pin Arm. The pin arm of the radiosonde is placed in the ON (down) position.

115. Duties of the Winds Team

The preflight duties of the winds team require approximately 30 minutes. While the temperature-density team makes the baseline check, the zone wind and ballistic wind plotters complete the inflation of the sounding balloon and prepare the balloon train.

a. The zone wind computer prepares DA Form 6-49 (Pressure-Time Chart) after the temperature-density team has accepted the radiosonde.

b. Upon completion and verification of the reference-temperature-humidity check, the zone wind computer repositions the RECORDS CONTROL switch to the STAND BY position and resets the TIME indicator on the control recorder to zero.

116. Preparation of the Pressure-Time Chart, DA Form 6-49

A table (fig. 64) for recording pressure and time for each reference contact is located on the pressure-time chart.

a. The following information should be en-

tered in the appropriate spaces of the table: station, location, flight number, date, release time, baroswitch serial number, computer, and checker.

b. The contact number corresponding to the surface pressure is entered in the bottom box of the left column and the surface pressure is entered in the center column.

c. In the left column, the numbered reference contacts lower than the contact number corresponding to the surface pressure are crossed out. For example, if the contact number corresponding to the surface pressure is 5.4, the contact number 5.0 is crossed out.

d. The pressure for each reference contact number listed in the left column is read from the appropriate radiosonde pressure calibration chart to the nearest whole millibar and recorded in the center column.

e. The right column is provided for recording the time each reference contact is reached. Times are obtained from the control-recorder tape and are entered as they become available during the flight.

117. Offset Release

The rawin set must begin automatic tracking immediately at release if low-level winds derived from the rawinsonde system are to be considered accurate. An offset release point of at least 100 meters is recommended in order to permit automatic tracking by the rawin set from the time of release. This offset distance is based on balloons with a rate of rise of approximately 300 meters per minute. For faster rising balloons, the offset distance must be increased proportionately with the rate of rise of the balloon; i.e., a 100-meter offset for balloons with a rate of rise of 300 meters per minute and a 170-meter offset for balloons with a rate of rise of 500 meters per minute.

STATION: <i>3rd Div Arty</i>		
LOCATION: <i> Ft Sill, Okla</i>		
FLIGHT NR: <i> 3</i>		
DATE: <i> 17 FEB 64</i>		
RELEASE TIME & TIME ZONE: <i> 1730 GMT</i>		
CONTACT NUMBER *	CONTACT PRESSURE (Mb)	CONTACT TIME (Min & Tenths)
(1)	(2)	(3)
120	79	58.4
115	88	55.0
110	104	51.5
105	120	48.8
100	140	46.0
95	162	43.5
90	186	40.8
85	213	37.6
80	240	33.1
75	270	32.6
70	314	29.5
65	338	x x x
60	373	x x x
55	413	22.8
50	455	20.6
45	500	18.2
40	548	15.7
35	600	13.3
30	653	11.0
25	710	8.7
20	772	6.6
15	837	4.4
10	914	1.6
5		
Surface	5.4	967
		0.0
MODULATOR NR: <i> 696900</i>		
BAROSWITCH		
COMPUTER: <i> Moore</i>		
CHECKER: <i> Scheurer</i>		
* CROSS OUT LINES FOR CONTACT LESS THAN RELEASE CONTACT NR.		

Figure 64. Recording contact pressure and time on Pressure-Time Chart (DA Form 6-49).

Section IV. TEAM DUTIES DURING BALLOON RELEASE

118. Duties of the Section Chief

The section chief is in charge of all operations at the moment of release and must coordinate the activities of all personnel to insure maximum speed and efficiency. He announces the type of release to be used and gives the command WARNING—RELEASE. Immediately after release, he insures that the rawin set is tracking and operating automatically. If necessary, he manually operates the rawin set until it is positioned on the radiosonde and then switches to automatic tracking. After 2 minutes, he sets the antenna control MANUAL-NEAR AUTO-FAR AUTO switch to the FAR AUTO position.

119. Duties of the Temperature-Density Team

Just before the command RELEASE, the radiosonde recorder operator positions the rawin TIME PRINT switch to the AUTO position. At the command RELEASE, he positions the RECORDS CONTROL switch on the control-recorder from STAND BY to FLIGHT. He verifies that the data are being properly received and notes the time of release. The temperature-density plotter evaluates the traces obtained during the reference-temperature-humidity check (2, fig. 74) for temperature and relative humidity and enters

these values opposite RELEASE DATA on DA Form 6-43 (Radiosonde Data) (fig. 87). He reads the barometer and enters the surface pressure opposite RELEASE DATA on DA Form 6-43, along with its contact equivalency.

120. Duties of the Winds Team

The zone wind plotter and ballistic wind plotter are responsible for performing the actual release. It is the responsibility of the man who releases the radiosonde to see that the pin arm is placed in the ON (down) position just before release and to determine the offset distance. After the release, the zone wind plotter measures the surface wind with the anemometer. Assisted by the ballistic wind plotter, he then polices the inflation area and prepares for the next flight. The balloon for the next flight is not inflated immediately after a release; but the charges, twine, and parachute may be set out and the balloon may be conditioned if required. Just before release, the zone wind computer insures that the control-recorder is ready (i.e., the PRINTINGS PER MINUTE switch at 10 prints per minute, the TIME indicator at zero, and the RECORDS CONTROL switch in STAND BY). The zone wind computer records the time of release on the pressure-time chart.

Section V. DUTIES OF TEMPERATURE-DENSITY TEAM DURING FLIGHT

121. General Duties

a. During the flight, the temperature-density team computes temperature and density values. The duties performed by each team member and the computations involved are described in this section.

b. The data determined by the recorder operator are used by the temperature-density plotter and the temperature-density computer, who determines the final zone and ballistic quantities. Each man on the team is responsible for checking the data received from the man before him. The station chief checks the entire set of data for inconsistencies before he records the results on the met message forms.

122. Flight Duties of the Radiosonde Recorder Operator

a. During the flight, the primary duty of the recorder operator is to evaluate the radiosonde recorder record. The recorder record is printed

automatically, but the recorder operator adjusts the print of each incoming low reference to a recorder division value of 95.0 with the reference adjust handwheel. Before making the adjustment, the operator should allow the recorder to print for a moment so that the beginning of the trace can be easily identified. The record should be evaluated as it becomes available.

★b. Once the record is evaluated the information is recorded on DA Form 6-43 (fig. 87). This information is then converted to pressure in millibars by using the radiosonde calibration chart and to temperature in degrees Celsius and relative humidity in percent by using the Humidity-Temperature Computer CP 223C/UM.

c. When the required altitude has been met (para 78f), the recorder operator rotates the SIGNAL SELECTOR switch to the SC position for 10 seconds, turns off the recorder, and completes the evaluation of the record. He then checks the data prepared by the temperature-den-

sity computer and assists with the computations of temperature and density before they are turned over to the section chief.

123. Evaluation of the Radiosonde Recorder Record

a. The general design of the recorder record is described in this paragraph, and the evaluation of the record is described in subsequent paragraphs of this section.

b. The radiosonde recorder record consists of a series of traces representing the values of temperature, relative humidity, and pressure. These traces are printed during a radiosonde flight on a chart containing a grid of vertical and horizontal reference lines. There are 101 vertical lines evenly spaced from one side of the record to the other. The space between two adjacent lines is defined as 1 recorder division. Each 10th vertical

line is numbered across the record from 0 on the left to 100 on the right (fig 65). Horizontal lines are spaced one-half inch apart on the recorder record (this spacing is consistent with normal paper feed speed of one-half inch per minute.) As a radiosonde is carried aloft, the values of temperature, pressure, and relative humidity are transmitted in the form of a pulse-modulated ultrahigh-frequency (UHF) signal which is received by the rawin set. The order of transmission is predetermined by the construction of the commutator bar. Modulation occurs in the audio-frequency range, and this met signal is printed on the record at a recorder division value equal to one-half of the frequency, i.e., a frequency of 120 Hz is printed at 60 recorder divisions. A discussion of how the values of temperature, relative humidity, and pressure are measured by the radiosonde and recorded on the chart by the radio-

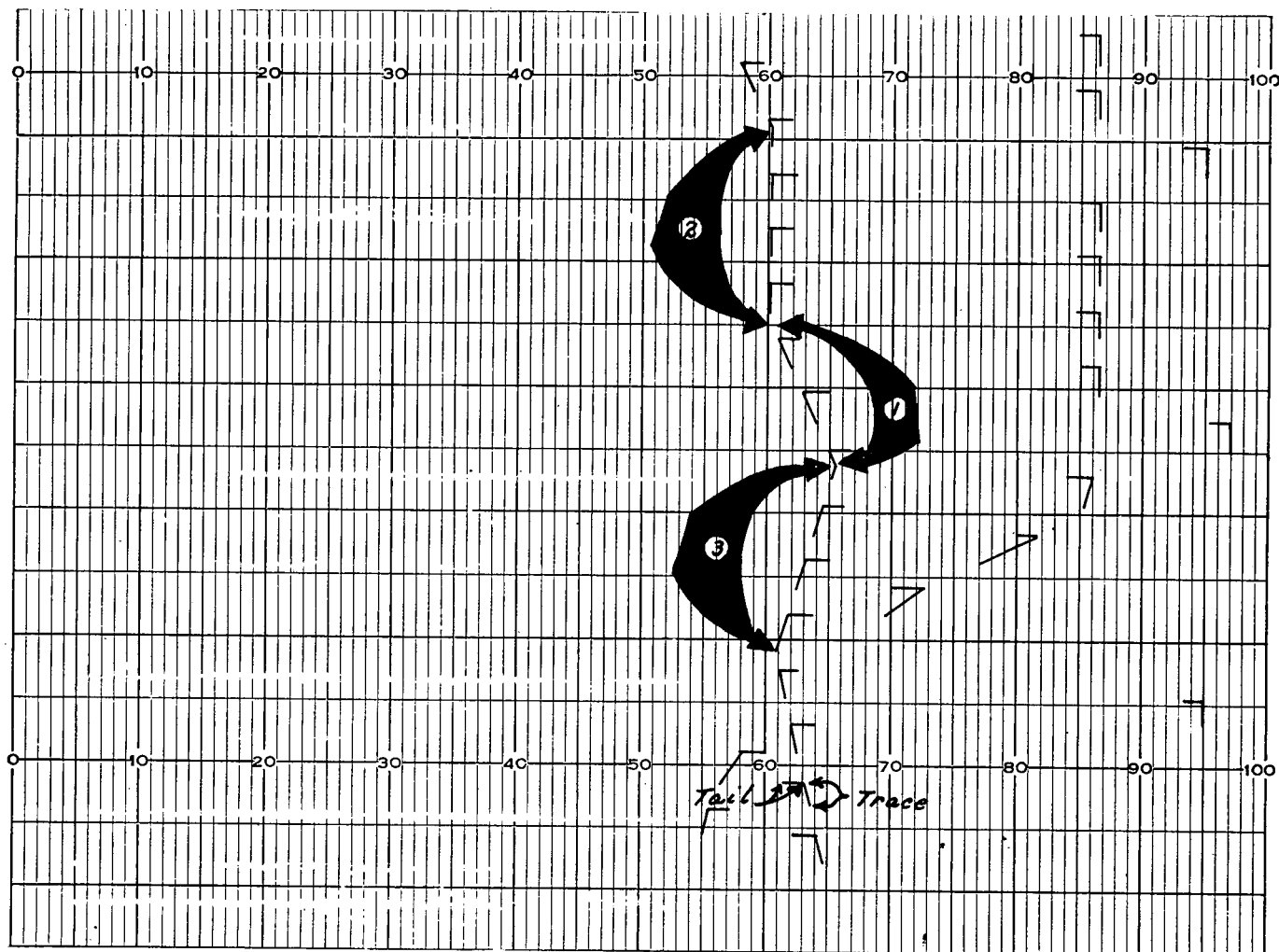

Figure 65. Recorder record showing a temperature trace pattern.

sonde recorder is presented in paragraphs 124 through 126.

124. Temperature

The electrical resistance of the temperature element is a function of its temperature. This principle is utilized in the radiosonde with the effect that a radio signal is transmitted which contains temperature information in the form of frequencies from 8 to 170 Hz. These frequencies vary directly with the temperature—the higher the temperature, the higher the frequency. Since recorder divisions are proportional to frequency, any temperature trace printed to the right of another represents a higher temperature. The horizontal portion of the print is the tail (which is always horizontal and at the top) (fig 65). The portion that is vertical, or inclined from the vertical, is the trace. The trace terminates at its junction with the tail. The trace is the usable part of the print, as it reflects the temperature measurement. Since the temperature normally decreases with height, a series of temperature traces often appears on the recorder record as shown by 1 in figure 65. Sometimes the temperature does not change with an increase in height. Such a layer of atmosphere is known as an isothermal layer. The temperature traces of an isothermal layer are shown by 2 in figure 65. An inversion layer is a layer of the atmosphere in which the temperature *increases* with height. An inversion layer is commonly found near the surface during the night or early morning hours. The temperature traces of an inversion layer are shown by 3 in figure 65. The actual point at which the temperature lapse rate changes direction may occur while a temperature trace is being printed or while the humidity or reference signals are being received. In the former case, the point at which the change occurs is clearly portrayed by a distinct change in direction of the temperature trace (top of 2 in fig 65). Since the entire length of the temperature trace is valid, the point of change of direction is easily located. If the actual point of change in direction of the temperature lapse rate occurs during the print of a reference or humidity signal, the location becomes somewhat more difficult to determine. In this case, the point of change of direction is assumed to be at the point of intersection of two adjacent extended temperature traces (bottom of 2 in fig 65). Isothermal or inversion layers may occur completely within one temperature trace, within a portion of a trace, or within a series of traces.

125. Relative Humidity

a. The humidity elements are so constructed that their electrical resistance varies with the relative humidity. The resistance of the carbon element (ML-476/AMT) varies directly with the humidity. Figure 66 shows a record made by a carbon humidity element. Higher relative humidities produce low recorder divisions on the record. Frequencies from 8 to 185 Hz representing humidity are transmitted by the radiosonde. The variation of humidity does not tend to follow any set pattern, as usually true of temperature. However, in the higher portions of the atmosphere, the moisture content is very low and may not be sufficient to be evaluated.

b. The relative humidity print is similar to the temperature print in that the horizontal portion is the tail and the portion that is vertical, or inclined from the vertical, is the trace. Humidity traces recorded from a radiosonde passing through a cloud layer are shown by 2 in figure 66.

126. Pressure

Contact numbers can be determined for any level on the recorder record and represent values of pressure. Contact numbers are converted to pressure by use of the radiosonde pressure calibration chart. The procedure for determining contact numbers is simplified by the use of easily identified reference traces. Two reference traces, high and low, are used (3, fig 66). Low reference traces are transmitted at 190 Hz, and printed at 95.0 recorder divisions; high reference traces are transmitted at 194 Hz and printed at 97.0 recorder divisions. Below the 105th contact, each contact that is a multiple of 5 is a reference contact. Each reference contact that is a multiple of 15 (except for the 15th contact) is a high reference and the others are low references. Above the 105th contact, each contact that is a multiple of 5 is a high reference and a low reference signal replaces the relative humidity signal.

127. Rules for Selecting Significant Levels

The recorder record contains a series of temperature and humidity traces representing the values of these meteorological conditions at all heights from the surface to the top of the sounding (humidity traces stop at the 105th contact). The purpose of record evaluation is to reproduce the temperature sounding curve, corrected for humidity on an altitude-pressure-density chart. One method of evaluating the record would be to evaluate the top and bottom of each trace, thereby

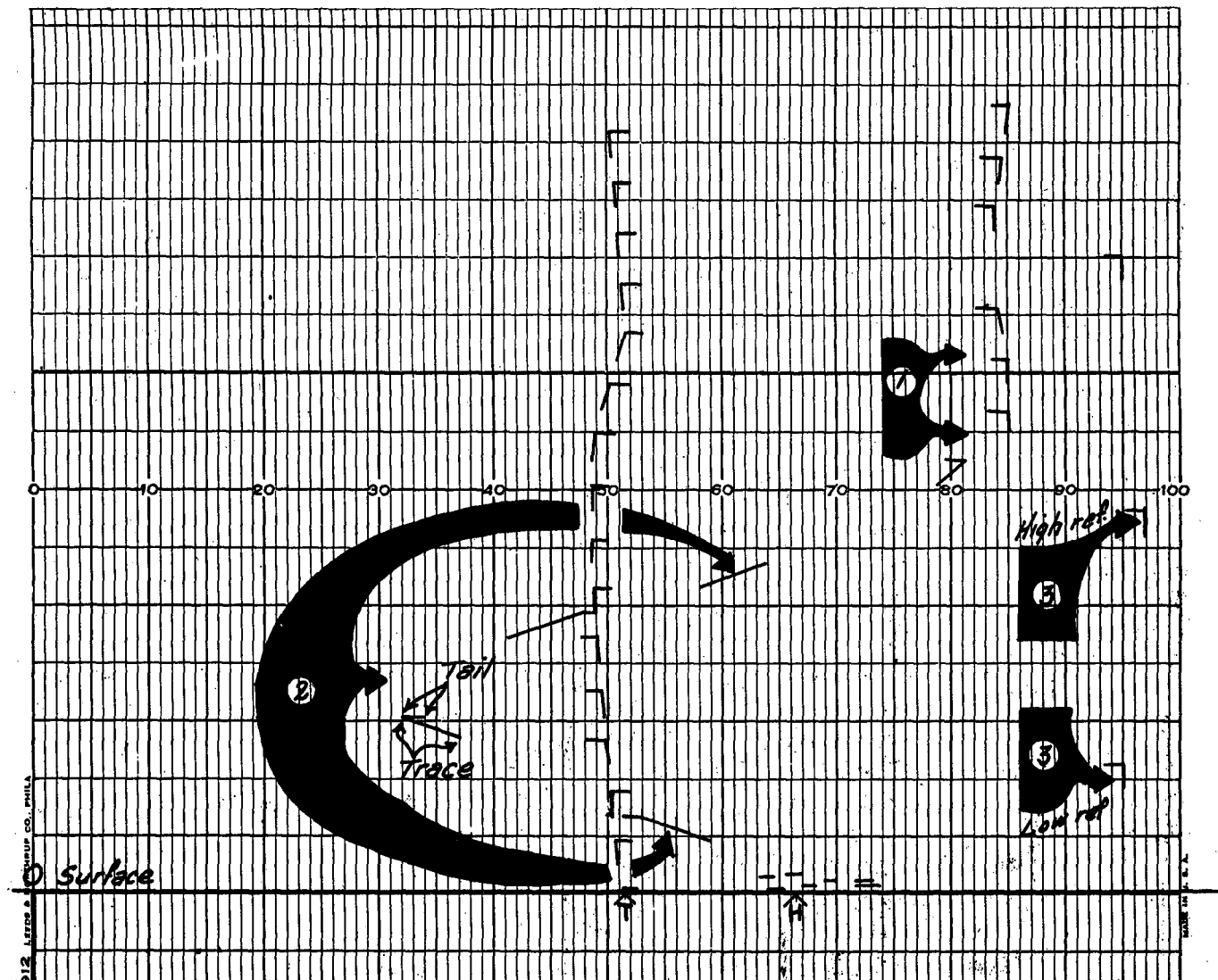

Figure 66. Typical humidity traces.

using all available data. This method would be acceptable if the accuracy of subsequent calculations warranted its use and if sufficient time were available to perform such a detailed evaluation. However, these considerations have led to another method of evaluation. This method allows a tolerance up to certain predetermined amounts and provides for evaluations to be made at points of significant change on the record. This method of evaluation is outlined in eight rules for selecting significant levels. The application of these eight rules insures that the requirements of the artillery are satisfied. On the recorder record the significant levels take the form of horizontal lines located as specified by the rules. These lines, or levels, are the only points on the record that are actually evaluated.

a. *Rule 1.* At the surface.

b. *Rule 2.* At the bottom and top of each significant isothermal layer.

c. *Rule 3.* At the bottom and top of each significant inversion layer.

d. *Rule 4.* At each point where the temperature traces vary from the temperature line of linearity by 1° C. or more or by 2° C. or more from 100 millibars to termination.

e. *Rule 5.* At each point where a relative humidity trace deviates from the humidity line of linearity by 10 percent or more.

f. *Rule 6.* At the beginning, end, and within any layer in which the temperature or humidity data is missing.

g. *Rule 7.* At certain mandatory pressure levels.

h. *Rule 8.* At the bursting point of the balloon or at the highest required contact on the record.

128. Application of Rules for Selecting Significant Levels

The application of the rules for selecting significant levels is discussed in *a* through *h* below. The significant levels and their evaluation are marked on the radiosonde recorder record (fig. 79). These levels are numbered, beginning with 0, immediately above the significant level lines on the left edge of the record. The numbers in parentheses below the significant level lines indicate the order in which the operator established the levels during the evaluation of the record.

★*a. Surface Level (Rule 1).* At surface, or release level, a line is drawn across the record from the point where the pen left zero recorder divisions and is labeled "surface" and numbered 0, as shown in figure 66. This level is not necessarily drawn through the bottom of the first trace printed on the record, since the first trace may be scattered or missing (fig. 66). Poor manual positioning of the radio direction finder just subsequent to release may result in the loss of the first signals transmitted. The offset release usually precludes the need for manual positioning. After the surface level has been placed on the record, the recorder division values corresponding to surface temperature and humidity (para 114*f*) are plotted and marked as in 1 and 2, figure 70.

b. Isothermal Layers (Rule 2). Levels are drawn at the bases and tops of all significant isothermal layers. The significance of isotherms is determined as follows: If a point within an isotherm deviates from the general trend of temperature by 1° C. or more, the isotherm is considered significant. Levels 1 and 2 in figure 67 are placed at the base and top of a significant isothermal layer. At 1 the isotherm clearly begins within a temperature trace; therefore, the level is placed at the exact beginning of the isotherm within the trace. However, when the significant change in the temperature lapse rate occurs between two temperature traces, the exact point of the change is determined by "trending"; i.e., extending the temperature traces bracketing the point of change as shown by 2 in figure 67. The significant level is drawn at the intersection of trend lines.

c. Inversion Layers (Rule 3). Levels are drawn at the bases and tops of all significant inversions. The significance of inversions is determined in the same manner as the significance of isotherms (*b* above). Levels 3 and 4 in figure 67 are placed at the base and top of an inversion layer. The

base of this inversion is recorded within a temperature trace (3, fig. 67); thus, the point of change of direction of the temperature trace is clearly defined on the record. The change in direction between the top of the inversion and the normal lapse rate following it occurs between two temperature traces (4, fig. 67). The exact point of this change is determined by trending these two temperature traces.

d. One Degree Celsius Deviation (Rule 4). A temperature line of linearity is drawn between two consecutive levels selected previously according to any of the eight rules except that no linearity line is drawn within missing data. The line of linearity is drawn between the point where the lower level intersects the temperature trace (or extension thereof) and the point where the upper level intersects the temperature trace (or extension thereof). An example of a temperature line of linearity is shown by 1 in figure 68. This line of linearity represents the temperature lapse rate between the levels at 2 and 3 in figure 68 that the temperature-density plotter would plot on chart ML-574 if no further levels were selected. The temperature traces must not deviate from the line of linearity by 1° C. or more. The deviation of the traces from the line of linearity is measured on a horizontal line. In order to determine whether or not the traces deviate by 1° C. or more from the line of linearity, the point of greatest deviation (4, fig. 68) is investigated first. A horizontal line or trial line is drawn at the point of greatest deviation. The temperature is evaluated from the two points where this line intersects with the line of linearity and the temperature trace (4 and 5, fig. 68). First the recorder divisions corresponding to each point are read from the record. Then, the humidity-temperature computer, set with the baseline data (fig. 63), is used to convert the recorder division values to degrees Celsius. If the greatest deviation is less than 1° C., no level is drawn at this point. If the deviation is 1° C. or more, a level must be drawn at this point and the two lines of linearity which are drawn to the level above and below this level (1 and 2, fig. 69) must be checked again for an accuracy of 1° C. In figure 69, level at 3 was selected because the temperature traces deviate more than 1° C. from the line of linearity. An additional level for a 1° C. deviation must be placed at 4. The application of this rule at 100 millibars and above allows for a deviation from the line of linearity up to 2° C. before the rule is applied.

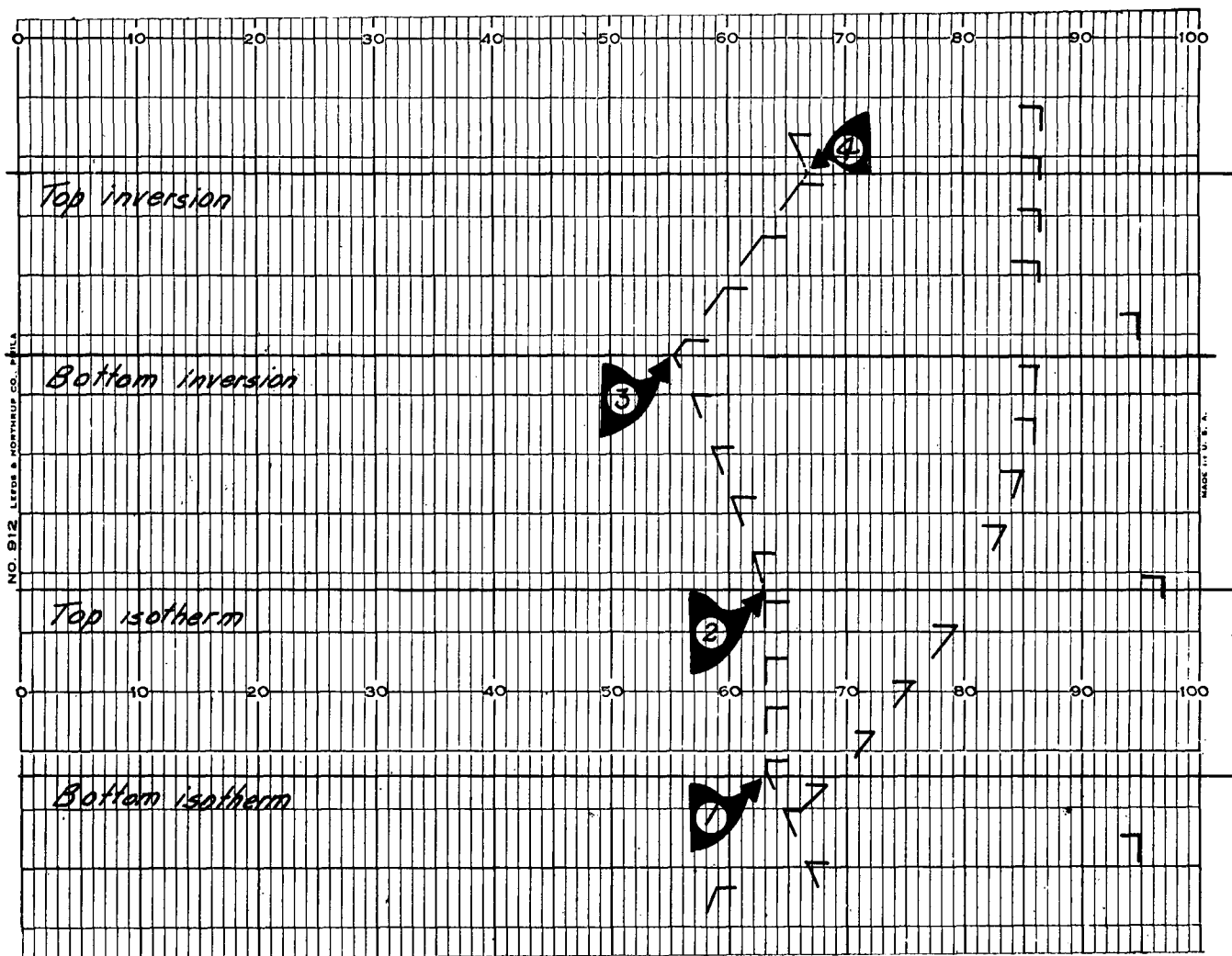

Figure 67. Isothermal and inversion traces.

★*e. Ten Percent Humidity Deviation (Rule 5).* A humidity line of linearity is drawn between two consecutive levels selected previously according to any of the eight rules except that no linearity line is drawn within missing data. The region between these levels is analyzed to determine if the humidity curve deviates from the line of linearity by 10 percent relative humidity or more. For example, sample data for determining humidity deviation are shown in figure 70 and discussed as follows:

(1) In the example (fig. 70), the first level selected above the surface is a mandatory level (3, fig. 70). This line of linearity (7, fig. 70) represents the humidity in this area which could be plotted by the temperature-density plotter if no further levels were selected.

(2) As with temperature deviations, the

point of greatest deviation (4, fig. 70) is investigated first. A trial level is drawn at this point. If the humidity corresponding to the intersection of the trial level and the humidity line of linearity (5, fig. 70) deviates from the humidity corresponding to the intersection of the trial level and the humidity trace (4, fig. 70) by 10 percent relative humidity or more, the trial level must be evaluated as a significant level.

Note. At high recorder division values the greatest recorder division deviation from a line of linearity may not be the greatest humidity deviation.

(3) The humidity values for the two points (4 and 5, fig. 70) on the trial level are determined with the humidity-temperature computer. The first step is to determine the temperature measured at the trial level. This temperature is the temperature corresponding to the intersection of

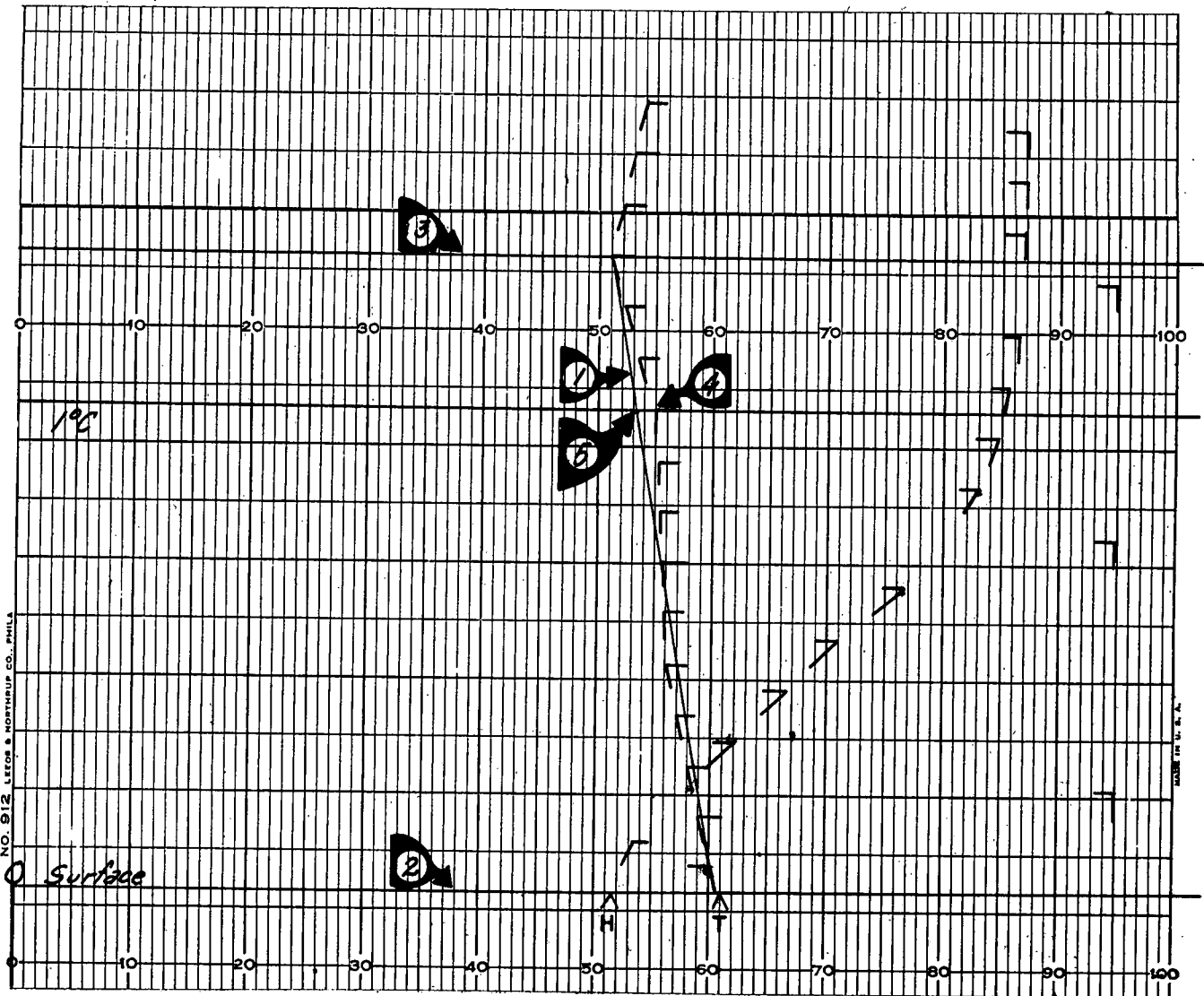

Figure 68. Test for 1° C deviation from a line of linearity.

the trial level with a temperature trace or extension thereof (6, fig. 70). The recorder division value for this point is converted to degrees Celsius with the computer. This temperature is used with the recorder division values for the two points being checked (4 and 5, fig. 70) to determine the corresponding humidities. In this case the deviation is greater than 10 percent and a significant level is entered at 4 in figure 70. Next this procedure is repeated between the surface and level 4 by drawing a line of linearity (8, fig. 70) and checking the point of maximum deviation (9, fig. 70) from the line of linearity.

(4) If the two relative humidities differ by

less than 10 percent, no significant level is required at the trial level (9, fig. 70). In this case, the record is checked for 10 percent deviation between level 4 and the mandatory level 3. Another line of linearity (10, fig. 70) is drawn and the above procedure is repeated for the region between 4 and 3. In figure 70, the deviation at 9 was checked with a humidity temperature computer; it was found that no significant level was required at 9.

(5) If the two relative humidities differ by 10 percent or more, the trial level is entered as a significant level. The areas above and below this new level must then be checked for more 10 percent deviations.

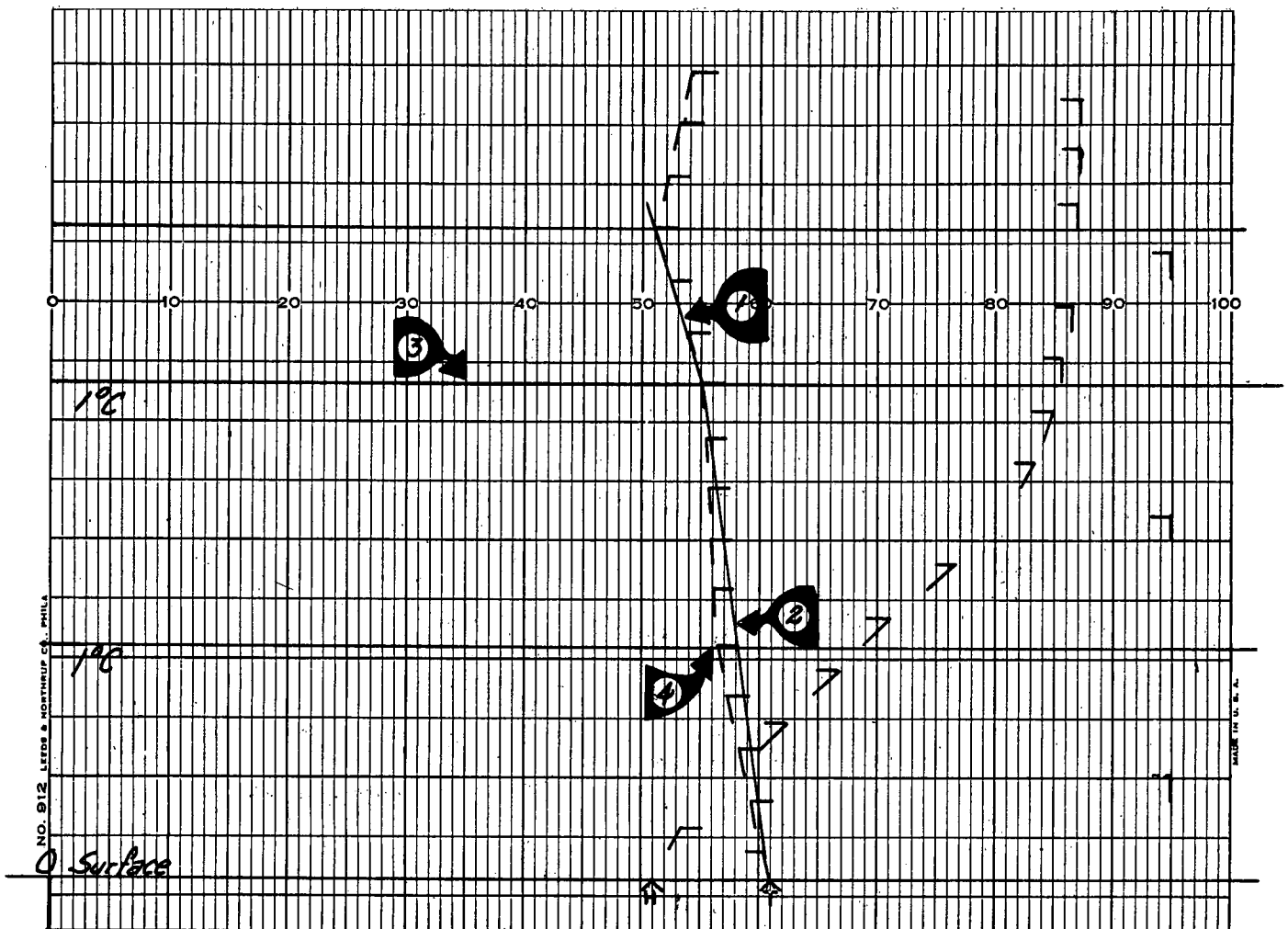

Figure 69. Determination of temperature deviation from line of linearity.

(6) This same procedure is followed between all consecutive levels (except that no line is drawn within missing data) regardless of the reasons for selecting the levels; i.e., the identical procedure that was followed in analyzing figure 70 would have been used had the mandatory level 3 been entered because it occurred at the bottom of an inversion, or had the surface level been the top of a missing data region.

f. Missing Data Levels (Rule 6). Levels at the beginning and end of missing data are selected to define the limits of usable information. The levels at 1 and 2 in figure 71 were selected by this rule. The lower level is drawn through the top of the last usable temperature trace printed before the area of missing data, and the upper level is drawn at the base of the first usable temperature

trace (or portion thereof) printed after the missing data. In addition, a level must be selected within the area of missing data; so the level at 3 in figure 71 was selected. To determine the contact number above the missing data level, the vertical distance between the last two usable reference traces below the missing data (4, fig. 71) is measured. This distance is divided into the total distance (6, fig. 71) between the last usable reference trace before the missing data level and the first reference trace above the missing data level. The result is used to determine the reference contact number above the layer of missing data. For example, in figure 71, the vertical distance between reference contacts 25 and 30 (below missing data) is measured as two inches. This two inches is graphically divided into the total distance (4 inches) by laying it off on the

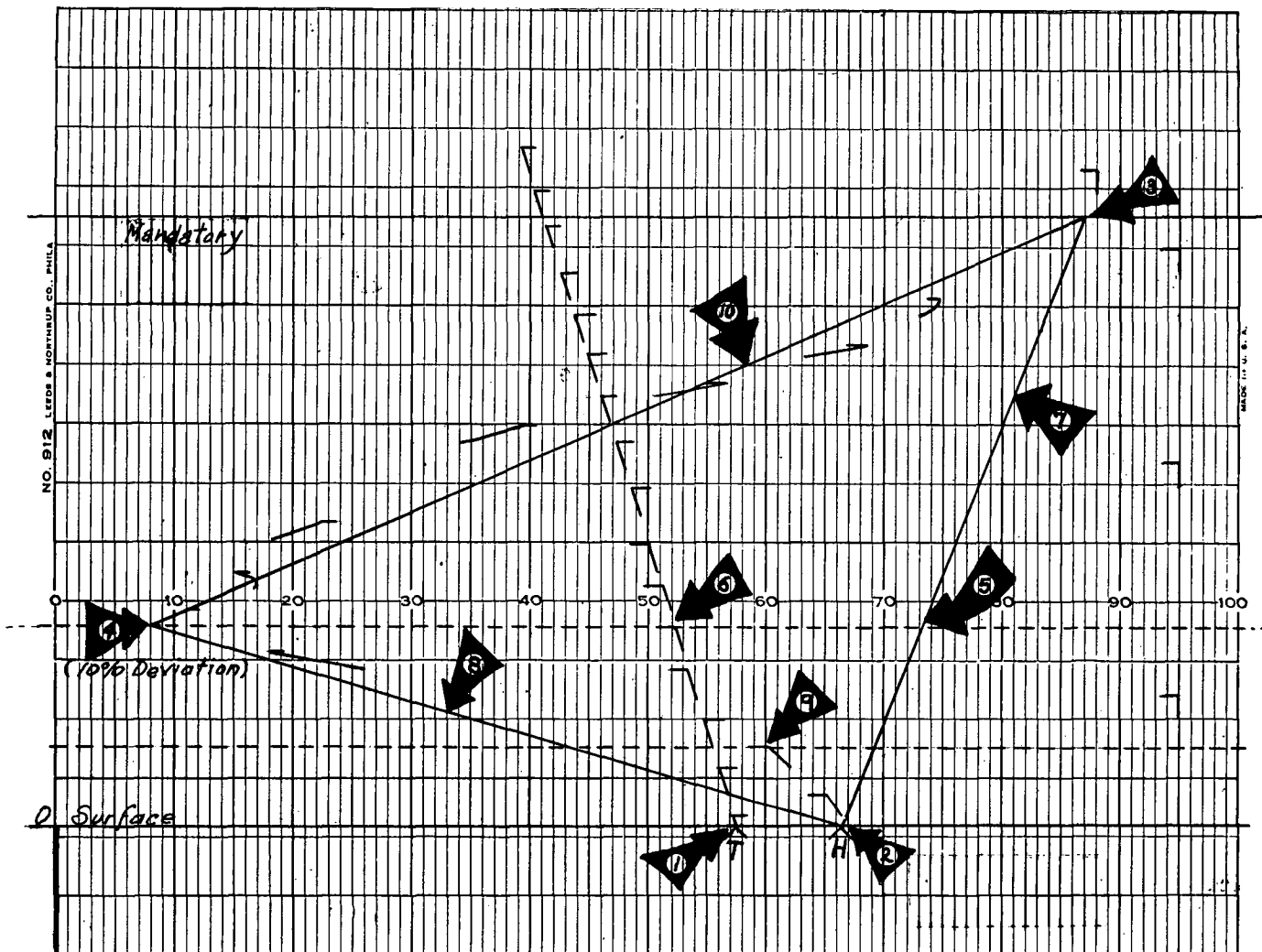

Figure 70. Humidity deviation from linearity.

record two times, from the last reference trace below the missing data (reference 30) to the first reference trace (5, fig. 71) above the missing data. Therefore, the first reference trace above the missing data is 40 (two reference contracts above 30). When fast-rising balloons are used, the determination of references may be more difficult.

★*g. Mandatory Levels (Rule 7).* Levels will be placed at 1000, 850, 700, 500, 400, 300, 250, 200, 150, 100, 70, 50, 30 and 10 mb to provide, common levels for Air Weather Service exchange.

h. Terminal Level (Rule 8). When the maximum altitude requirement for radiosonde data is obtained prior to balloon burst, a terminal level

is drawn at the appropriate contact. Otherwise, a terminal level is drawn at the level corresponding to the bursting point of the balloon. The point of the balloon burst on the recorder record is determined by the following characteristics: The traces printed after the balloon burst are shorter than those before the burst, since the radiosonde descends faster than it ascends; the temperature and humidity traces printed after the burst correspond in reverse order to the temperature and humidity traces printed before the burst; and the reference traces are printed in reverse order of their original printing. The point of burst is fixed by determining the contact numbers of the traces printed between the last reference trace during the ascent and the same reference trace

after the burst. In figure 72, the burst occurred at 1, during a temperature trace. This trace was located by inspecting the temperature traces and by assigning contact numbers to the temperature traces immediately above and below the burst. The position of the burst point within the trace is determined by comparing the lengths of the traces before balloon burst with the length of the traces after burst. In figure 72, the traces printed after the burst are about one half as long as the traces printed before the burst. In determining the contact number of the level of bal-

loon burst, the last full contact below this level is used as a measure. Thus, the operator lays off the vertical distance of the last full contact on the straight edge of a piece of paper by use of tick marks, places it vertically on the chart with the lower tick mark coinciding with the top of the last full temperature trace. He then visually interpolates the level of balloon burst to the nearest tenth of a contact. In this case, the correct contact is determined to be 90.8. When the bursting point occurs during a ref-

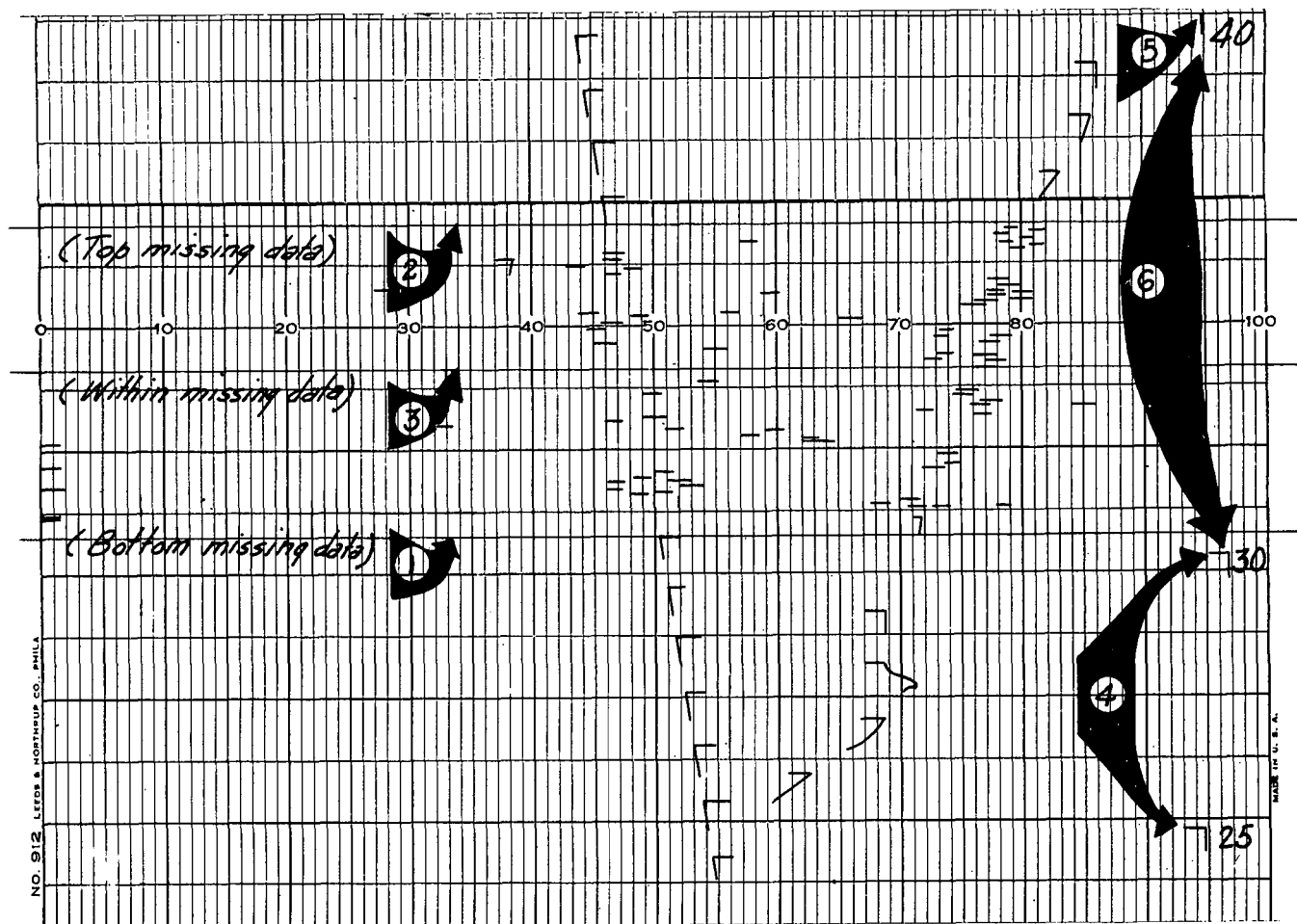

Figure 71. Missing data.

erence or a humidity trace, the evaluation of the flight will be terminated at the top of the last usable temperature trace. When all or part of the last temperature trace has a decidedly rounded appearance and indicates a marked increase in temperature that is not supported by the lapse rate of the trace immediately preceding, the terminating level will be placed at the point where the marked increase begins. The radiosonde must be tracked until a high reference trace has been obtained after balloon burst.

129. General Procedure for Selecting Significant Levels

The first significant level selected on a recorder record is the surface. Above the surface, no specific procedure can be established for the selection of significant levels, since the rules for selecting significant levels apply to the temperature, humidity, and pressure of the atmosphere—meteorological conditions which are extremely variable. However, a general procedure has been

established for selecting significant levels. This general procedure encompasses all the rules for selecting significant levels and is still flexible enough to apply to any given set of atmospheric conditions recorded on the radiosonde recorder record.

a. Procedure in Making Selection. The general procedure for selecting significant levels is as follows:

(1) Scan the record from the surface level upward for the presence of an isotherm, an inversion, a layer of missing data, or a mandatory level.

(2) Draw a level through the bottom and top of an isotherm, an inversion, and a layer of missing data and through a mandatory point, whichever is encountered first (rules 2, 3, 6, and 7).

b. Linearity Requirements. Between adjacent levels established in *a* above (including the surface level), the temperature and humidity linear-

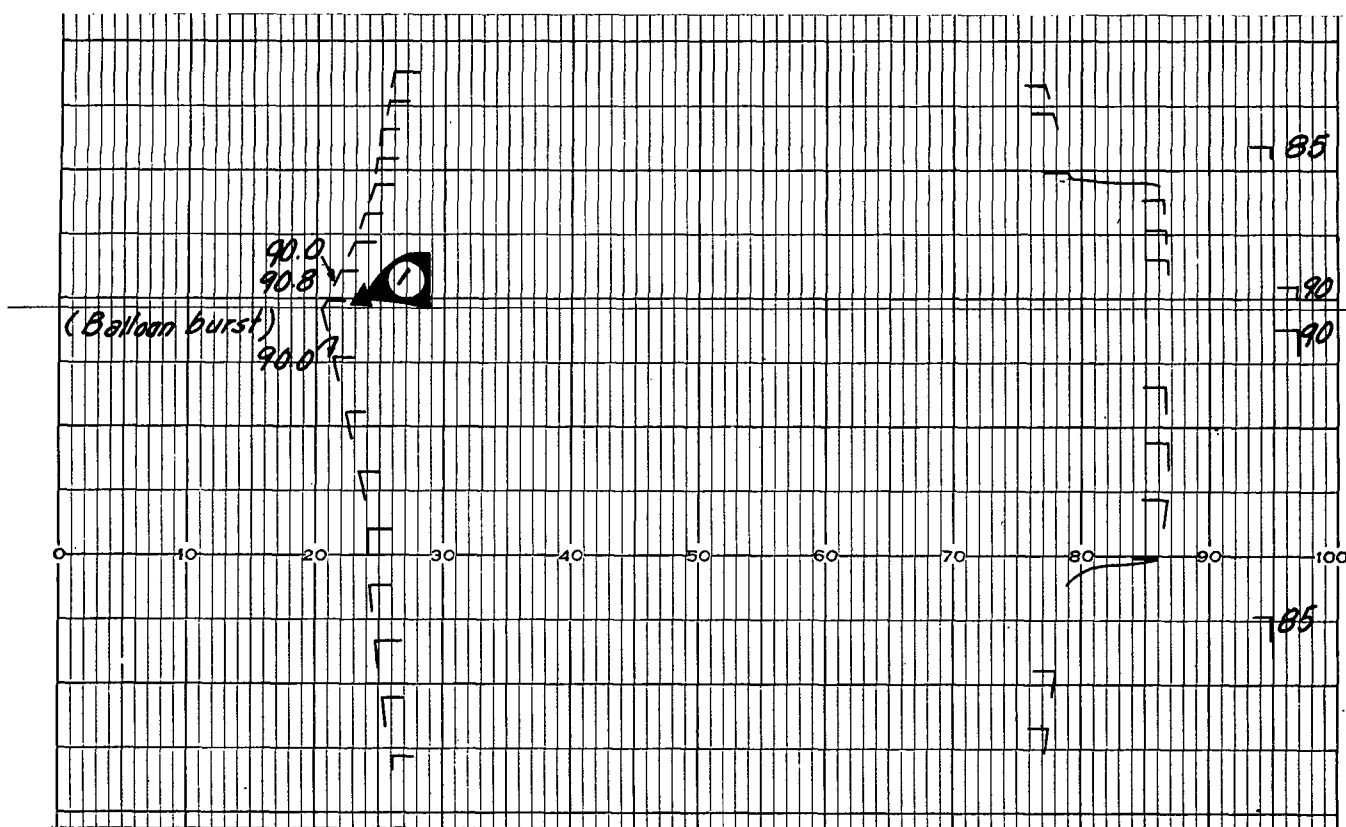

Figure 72. Terminal layer.

ity requirements are investigated and a level is drawn where required (rules 4 and 5).

c. Evaluation. All of the levels selected in *a* and *b* above are evaluated and recorded on DA Form 6-43 (Radiosonde Data).

d. Continuation of Selection of Significant Levels. After the procedures outlined in *a* through *c* above have been applied, the selection of significant levels is continued upward. When the next level has been selected, the temperature and humidity linearity requirements (*b* above) are checked, and the selected levels are evaluated (*c* above). Successive applications of this procedure are made until the recorder operator encounters the terminal level. When the terminal level is reached, the recorder operator draws a level through this final point (rule 8) and checks the linearity requirements through the last unevaluated stratum of the record. All established levels are evaluated and recorded on the radiosonde data sheet.

e. Expediting the Selection of Significant Levels. If no definite reason can be found for selecting a level within a sizeable area of the record (according to the judgment of the recorder operator), the process of evaluation is speeded up by

selecting a new level at a point representing significant changes in the curves of temperature and humidity. In general, points of significant change are points through which levels would have been selected to satisfy the linearity requirements, if there were levels available for constructing the lines of linearity. The selection of a level through a point of significant change in temperature traces is illustrated at 2 in figure 73. There is no definite reason for selecting a significant level from contact number 25 (1, fig 73) up to contact number 36.5 (3, fig 73). If the recorder record is advancing at a speed of one-half inch per minute, this point is not available to the recorder operator for about 5 minutes after the point of significant change. By immediately selecting a level at the point of significant change (2, fig 73) instead of waiting for a definite reason for selecting a level, the recorder operator is able to evaluate the temperature, humidity, and pressure data earlier. Also, the other members of the temperature-density team, the plotter and computer, can begin their duties sooner. This same procedure can be applied to significant changes in relative humidity. The selection of levels through points of significant change requires a thorough knowledge of

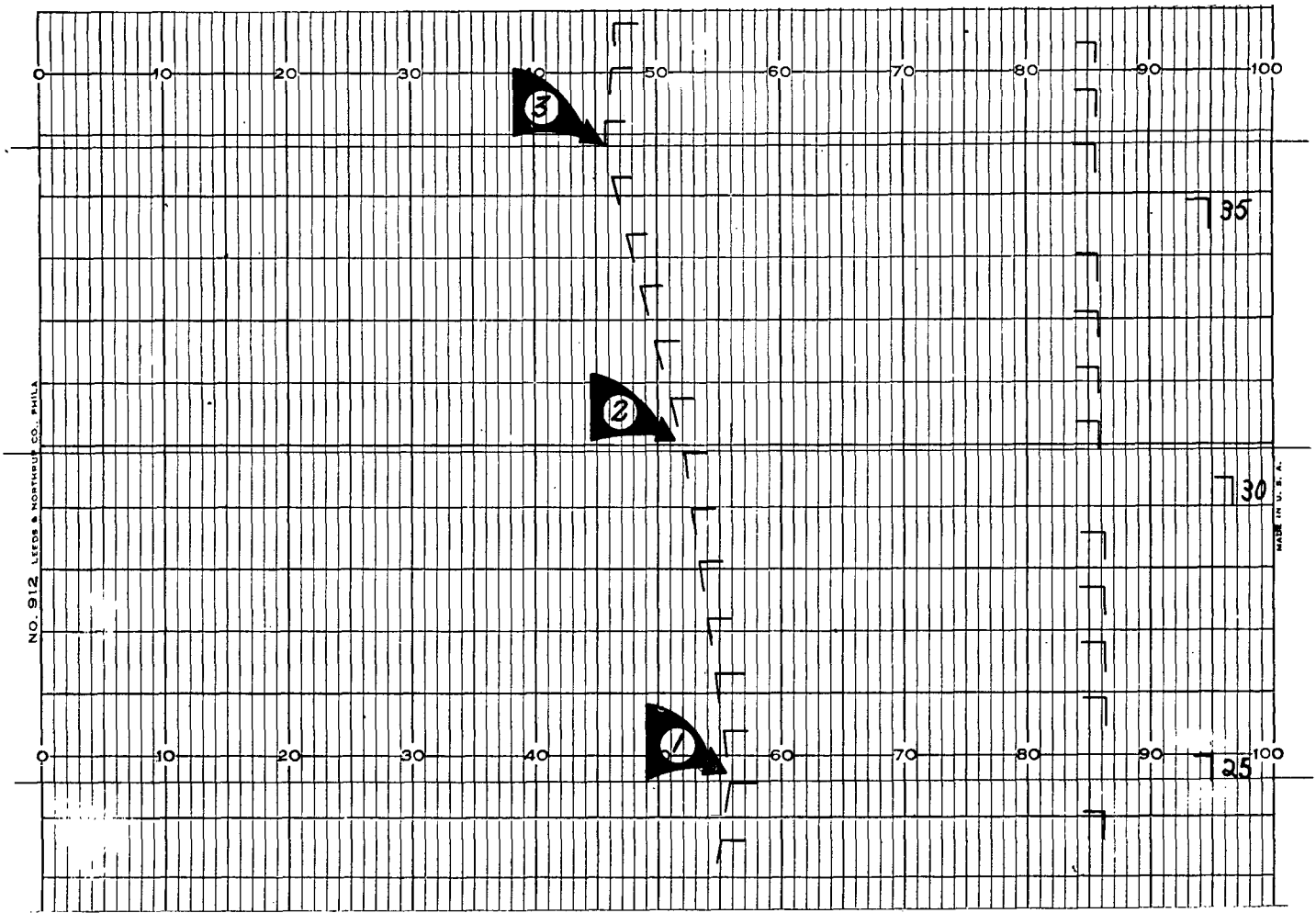

Figure 73. Significant change in temperature traces.

the rules for recorder record evaluation. It should be kept in mind that when the selection of levels has been completed and the evaluated data plotted on chart ML-574/UM, the resulting curve must closely reflect the temperature profile of the recorded traces. This procedure should not be adopted by anyone who has not had considerable practice and experience in applying the rules.

f. Illustration. The radiosonde recorder record (fig 79) is evaluated in accordance with the general procedure in *a* through *e* above. The order in which each significant level was selected is entered in parentheses below the level line in the left margin of the record. The selection rule is also entered below the level line on the record. These numbers and rules are not normally entered on the record but are shown here for identification purposes only.

130. Evaluation of Significant Levels

The evaluation of significant levels selected on

the recorder record is performed in several steps. First, the surface observations at the time of reference-temperature-humidity check are recorded on the record, and the surface level is evaluated for the release contact number. Then, the level contact number, the temperature recorder divisions, the humidity trace recorder divisions, and the sequence number of the level are evaluated from the record for each significant level aloft. Next, certain pertinent corrections are applied to these values. Finally, the corrected values are recorded on DA Form 6-43.

131. Recording Surface Observations at Release

Surface observations are obtained during the reference-temperature-humidity check. This information, plus certain other necessary facts, is entered on the recorder record. After the surface level has been drawn on the recorder record, certain items of information are entered on the re-

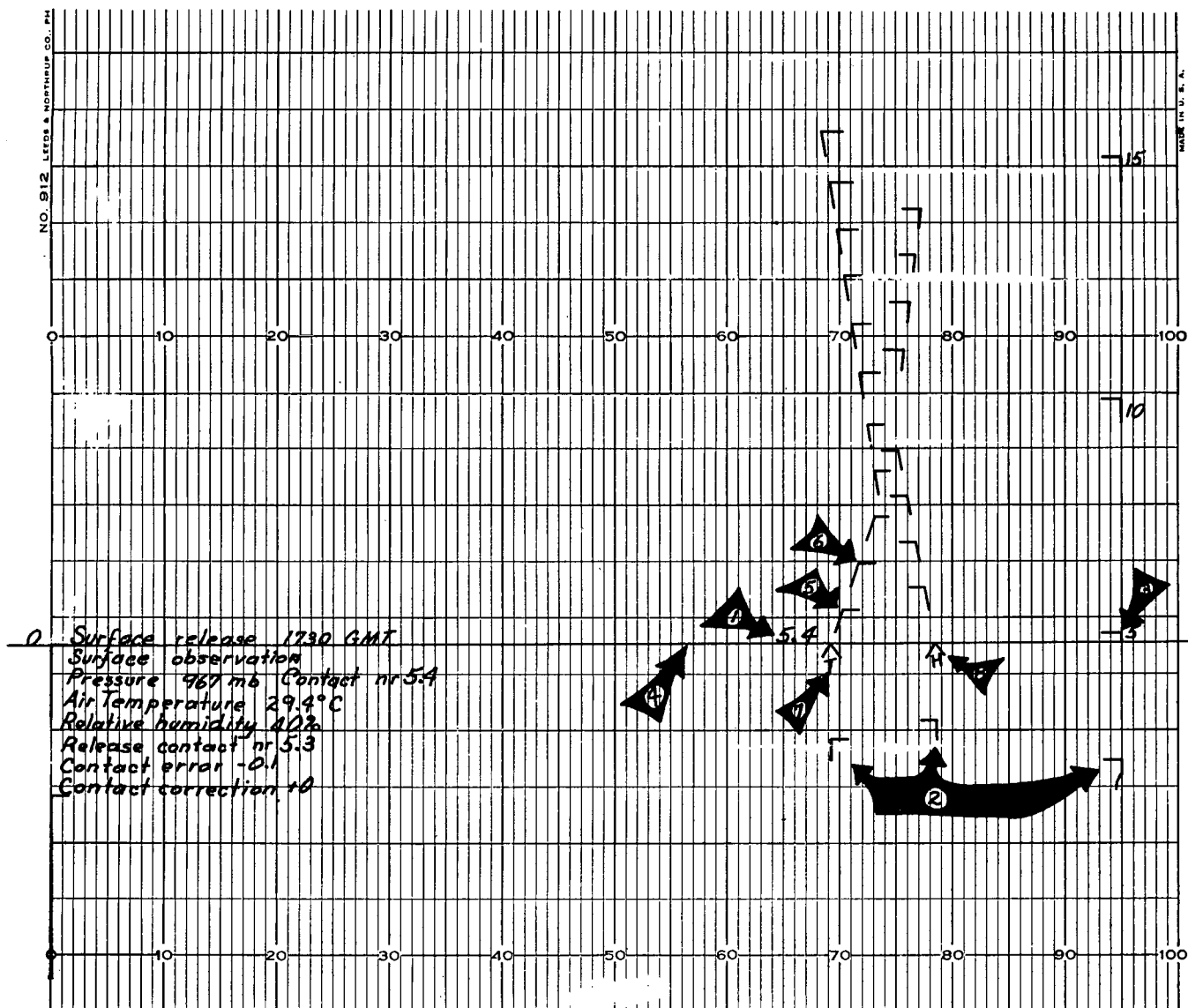

Figure 74. Surface observations and release level evaluation.

cord as shown in figure 74. These items are listed below.

a. The words "surface release" and the Greenwich mean time (GMT) of release, immediately above the surface level.

b. The words "surface observations", immediately below the surface level.

c. The surface pressure in millibars and the contact number corresponding to this pressure on the radiosonde calibration chart.

d. The temperature of the outside air to the nearest 0.1° C. determined by the temperature element.

e. The relative humidity in percent determined by the humidity element.

f. The actual release contact number determined

from the traces on the record. This release contact number is also entered above the surface level to the left of the first temperature trace (1, fig 74).

g. The contact error which is obtained by algebraically subtracting the contact number corresponding to the surface pressure (c above) from the actual release contact number (f above). The pressure contact number (c above) is considered the correct value.

h. The contact correction which has the sign opposite to that of the contact error in g above.

132. Evaluation of Release Level

a. The first step in evaluating the surface contact number is to identify and label the first ref-

erence trace printed after release of the radiosonde (3, fig. 74). The normal method of determining the contact number of the first reference trace is based on the fact that the recorder operator must know the contact setting of the pin arm corresponding to the surface pressure (para 106). He therefore can determine the contact number of the first reference trace printed. A contact begins at the top of a temperature trace and includes the following humidity or reference trace and the following temperature trace. Thus, the top of each temperature trace corresponds to a whole numbered contact. With the contact number of the first reference trace printed after release as a starting point, the operator counts whole contacts down the temperature traces to the top of the first temperature trace printed after release. He then compares the distance from the release level to the top of the first temperature trace with the distance occupied by the first whole contact to determine the fractional part of the contact printed before the top of the first temperature trace. This fractional part is subtracted from the first whole numbered contact to determine the release contact number to the nearest tenth. This contact number is recorded just above the surface level and to the left of the temperature traces (1, fig. 74). In figure 74, release occurred within contact number 5; i.e., the first reference. In order to determine the release contact number within the fifth contact, the contact beginning at 6.0 (5, fig. 74) and ending at 7.0 (6, fig. 74) is inspected. The distance from contact 6.0 to contact 7.0 is measured by laying a strip of paper along the traces and marking off the contact distance. The portion of the fifth contact printed after release is determined by comparing the distance from surface level to five with contact length marked on the strip of paper. In figure 74 the portion of the fifth contact printed after release is 0.7 contact. This portion is subtracted from the first whole-numbered contact (6.0) to determine the contact number at release ($6.0 - 0.7 = 5.3$).

b. Surface observations are based on the values obtained by the sensing elements of the radiosonde just prior to release during the reference-temperature-humidity check (2, fig. 74). In order to keep the stratum between the release level and the first significant level aloft within the required 1° C. and 10 percent humidity linearity, these surface values must be plotted and used in determining linearity. Each value is then plotted on the release level with a " \wedge ", and the temperature and humidity are marked

with a "T" and "H", respectively (7 and 8, fig. 74).

133. Significant Levels Aloft

a. *Contact Number.* Contact numbers for levels aloft are determined in a manner similar to that of determining the contact number of the surface level (para 132). The determination of the contact number of a level aloft normally is begun at one of the reference traces which bracket the level, and the count from the reference trace to the level may go either up or down. Since the relative lengths of the traces will vary, it is important that contact numbers for significant levels be determined with reference to the whole contact in which the level is drawn, rather than by assigning fractional contact values to the various traces. That is, a temperature trace, for example, will not necessarily be 0.7 of a contact. Each significant level is assigned a contact number based on the location of the level within the whole contact. In order to facilitate the evaluation of level contact numbers, all reference traces should be numbered (fig. 74).

b. *Temperature Recorder Divisions.* The uncorrected value of temperature recorder divisions for each level is read at the point of intersection of the level with the left edge of the temperature trace. When the significant level line does not intersect a temperature trace, the value of the recorder divisions is established at the point of intersection of the significant level line and a line drawn from the top left edge of the lower trace and the bottom left edge of the upper trace. The value of temperature ordinate is read and recorded to the nearest 0.1 recorder division.

c. *Humidity Recorder Divisions.* The uncorrected value of humidity recorder divisions for each level is read at the point of intersection of the significant level line and the humidity trace. When the significant level line does not intersect a humidity trace, the uncorrected value of humidity is established at the intersection of the significant level line and a humidity trend line according to the following:

(1) When the humidity traces immediately above and below the level follow the same general trend, a straight line is drawn connecting the traces immediately above and below the level (fig. 75).

(2) When a humidity trace reverses direction or is displaced at the level, the temperature traces are examined. If the temperature traces above the level trend more to the right than those

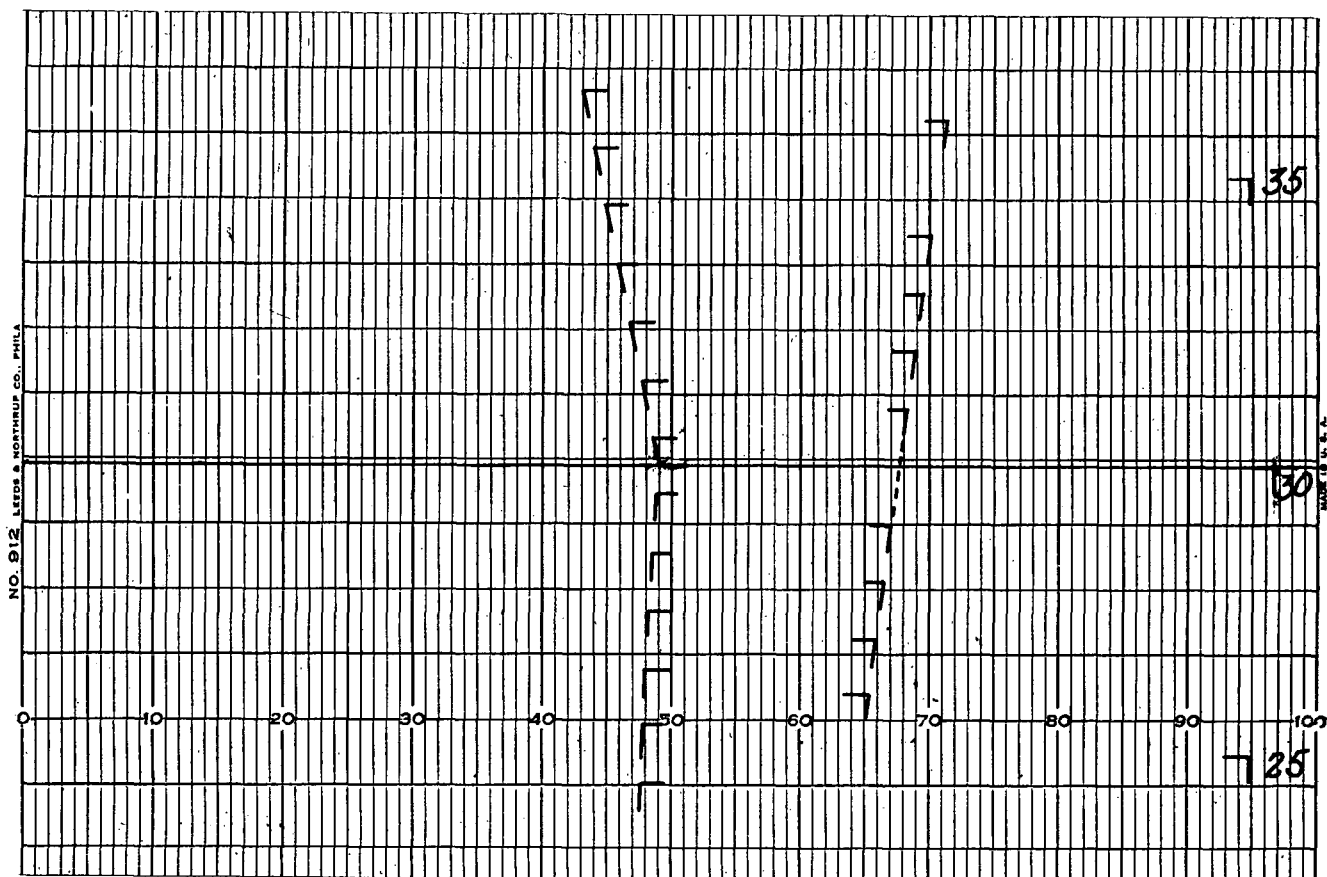

Figure 75. Humidity traces aligned.

below the level, a straight vertical line is drawn to extend, to the level line, that part of the adjacent humidity trace which has the higher value of relative humidity (1, fig. 76). If the temperature traces above the level trend more to the left than those below the level, a straight vertical line is drawn to extend that part of the adjacent humidity trace which has the lower value of relative humidity (2, fig. 76).

★(3) The lower limit of measurable relative humidity is approximately 10 percent throughout the temperature range of the carbon element. Whenever, at levels above the surface, the indicated relative humidity appears to be less than 10 percent (whenever any combination of temperature and recorder division values yields less than 10 percent when using the humidity-temperature computer CP-223C/UM), the value will be regarded as 10 percent and used for all purposes as an accurate value. This means that there will be no breaks in the vertical relative humidity profile owing to ambient conditions being less than the minimum operating range of the element.

(4) Whenever the indicated relative humidity value exceeds 100 percent, the humidity will

be regarded as 100 percent and used for all purposes as an accurate value.

d. Level Number. The levels are numbered in sequence, starting with the surface level as zero and ending with the terminal level. The level is numbered after all the rules for selecting levels have been applied to the area below it. Levels selected within areas of missing data are assigned a level number and evaluated as missing data.

★*e. Wet-Bulb Effect on Temperature.* When the radiosonde passes through a cloud, moisture may condense on the temperature element. After the radiosonde emerges from the cloud into dry air, the moisture evaporates and cools the temperature element. This cooling may cause the temperature trace to slope sharply to the left on the recorder record for a shallow stratum until all the moisture has evaporated from the element. This effect is known as the *wet-bulb effect*, and the temperature traces so effected are treated as missing data from the cloud top to the level at which the temperature trace resumes normal lapse, inversion or isothermal (1, fig. 77).

f. Multiple Ascents. When multiple ascents occur due to icing, heavy rain, or turbulence, the highest altitude (lowest pressure) on the initial

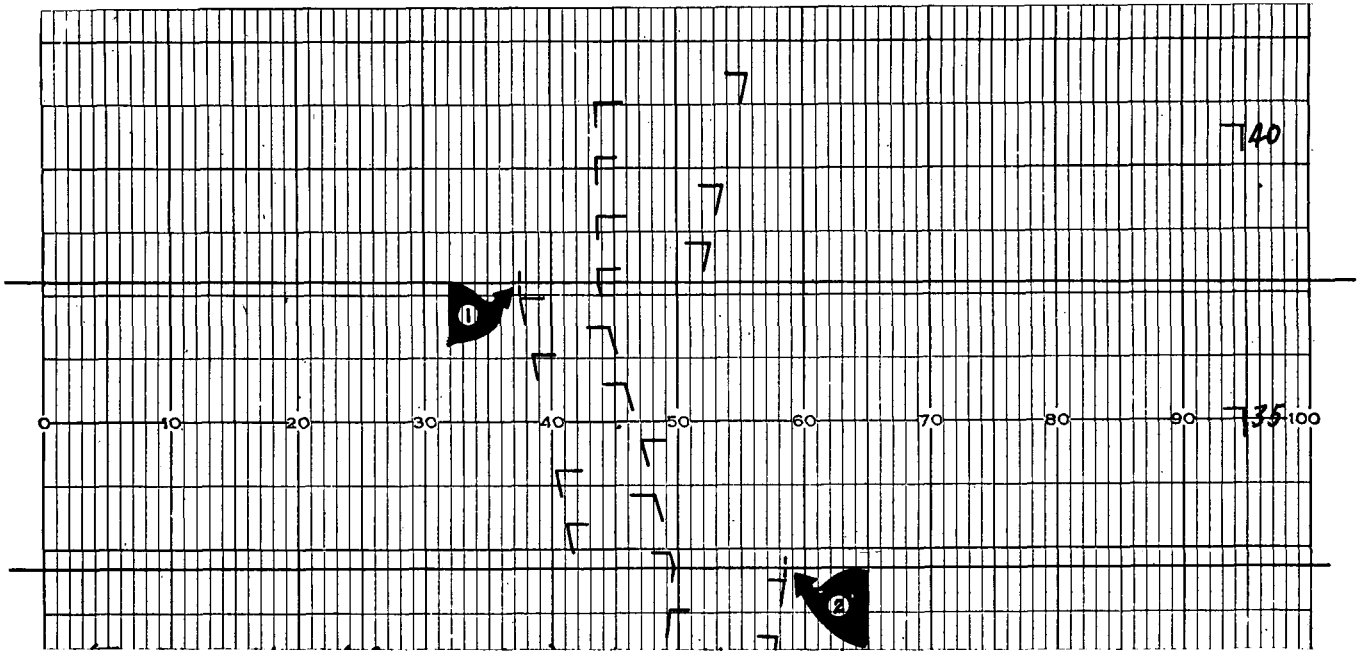
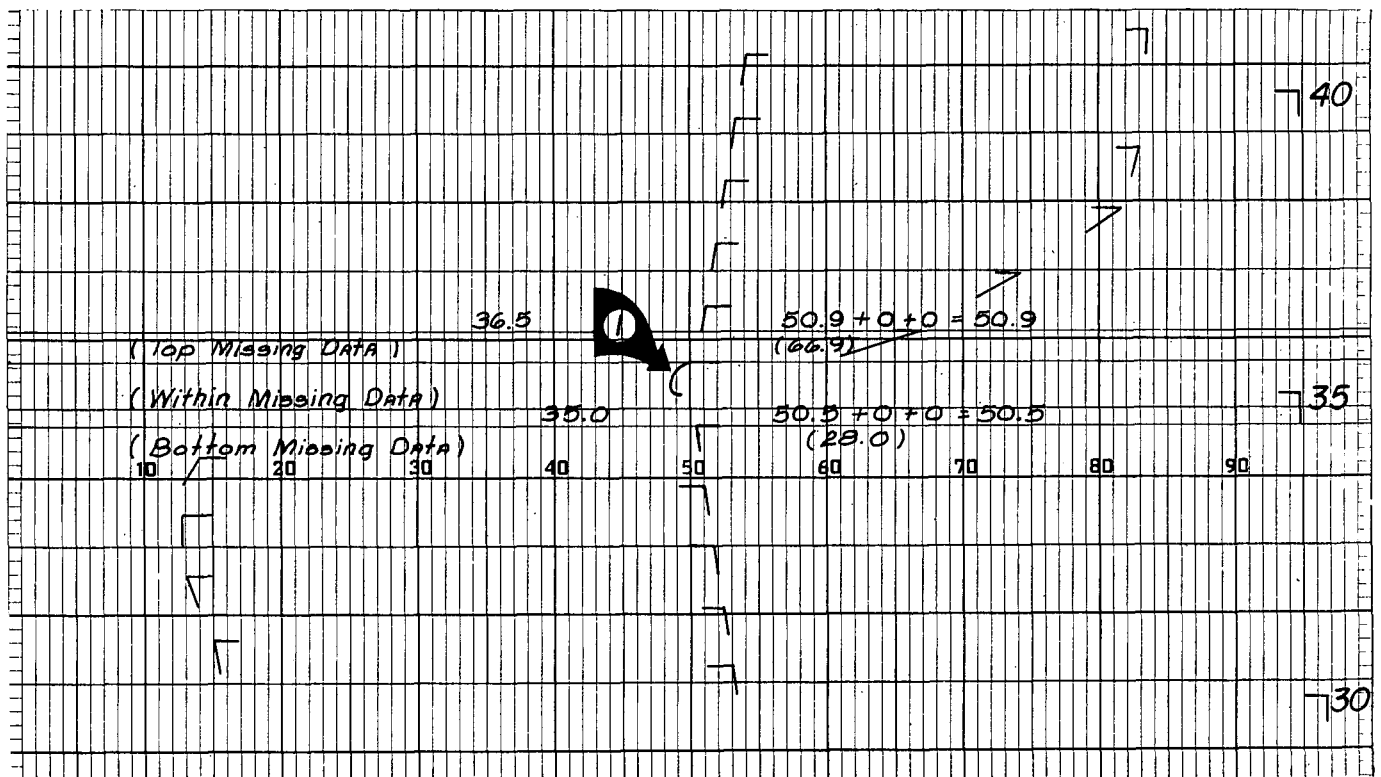

Figure 76. Humidity traces displaced.



★Figure 77. Evaluation of humidity at level of changed and wet-bulb effect.

ascent is evaluated. When the balloon resumes its ascent, the same pressure level is evaluated on the final ascent.

g. Recording Evaluated Data on Significant Levels. The uncorrected contact number, the uncorrected values of temperature and humidity re-

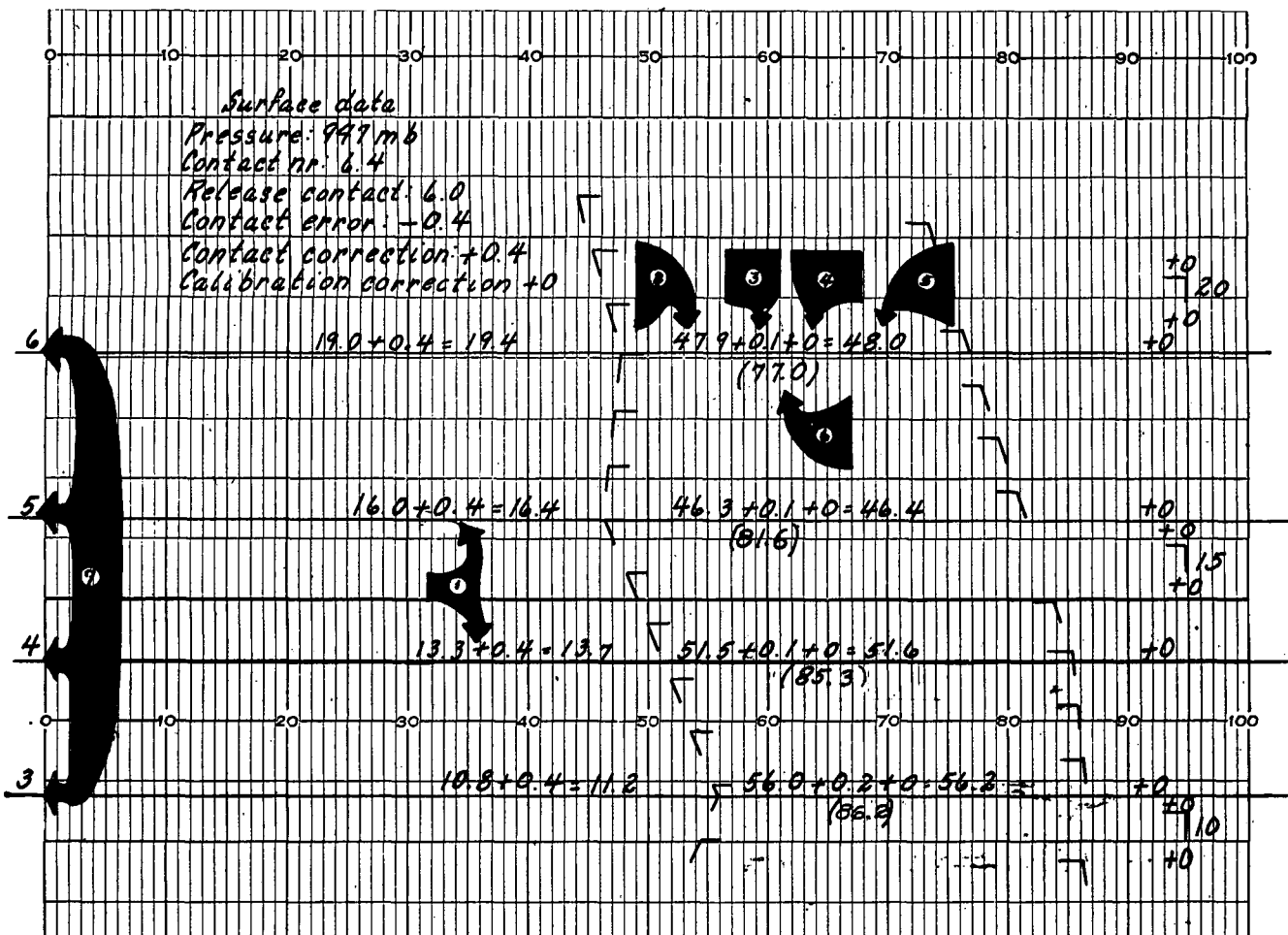

Figure 78. Evaluating significant levels and applying contact and calibration corrections.

correction divisions, and the number for each level evaluated are entered directly on the recorder record. Corrections to these values, where applicable, are also entered on the record. Contact numbers are entered above each level and to the left of the temperature trace. If a contact number correction is required, the correction is algebraically added to the contact number on the record as shown at 1 in figure 78. If no contact number correction is required, the value read from the record is the only value recorded (fig. 79). Uncorrected temperature recorder divisions are entered above each level line and just to the right of the temperature trace (where space permits) (2, fig. 78). After the uncorrected recorder division, value, a recorder calibration correction (3, fig. 78) is entered, followed by either a frequency drift correction or a combined frequency shift plus drift correction (4, fig. 78). These values are added algebraically and the sum, the corrected recorder division value (5, fig. 78) is entered after the drift correction. The methods of determining the corrections for the recorder

calibration, the frequency drift, and the frequency shift plus drift are explained in paragraph 134b through g. Uncorrected humidity recorder divisions are entered beneath each level and to the right of the temperature trace (6, fig. 78). Humidity recorder division values are corrected only under certain circumstances, as described in paragraph 134i. If a calibration correction and a drift correction or a shift plus drift correction are required, they are recorded in the same manner and sequence as the corrections for temperature recorder division values. All humidity evaluations are included in parentheses to aid in their identification. The level number is entered above each level in the left-hand margin of the chart (7, fig. 78).

Figure 79. Radiosonde recorder record.
 (Located in back of manual)

Figure 79—Continued.
 (Located in back of manual)

134. Corrections to Significant Level Evaluations

Several types of corrections are applied to the data evaluated from the significant levels. Level contact numbers are subject to a correction for erroneous pin arm setting. Recorder division values of temperature must be corrected for errors introduced by recorder misalignment and by drift or shift of the radiosonde pulse frequency. These values are also subject to corrections for inadvertent high reference adjustment and paper drift, which results from faulty operation of the radiosonde recorder. Humidity recorder division values must also be corrected for these errors when the total correction exceeds a certain limit (*i* below).

a. Contact Correction. The contact correction is determined by comparing the release contact number obtained from the radiosonde pressure calibration chart with the surface pressure reading taken at release. If the contact correction is 0 or ± 0.1 contact, it is disregarded. If the contact correction is greater than ± 0.1 contact, the contact numbers evaluated on the recorder record are corrected by the amount of the contact

correction. The correction is applied to each significant level (1, fig 78). In addition, the pressures corresponding to the corrected contact numbers must be read correctly from the radiosonde pressure calibration chart. (When discrepancies occur, the pressure-time plot data must be adjusted accordingly.) Contact discrepancies of 0.5 contact or more cannot be adequately corrected. When this situation exists, the flight should be disregarded and a new release initiated immediately.

b. Calibration Correction. The linearity calibration correction is applied by the recorder operator during the flight. The linearity calibration correction chart is constructed by the recorder operator during the linearity calibration test, as described in TM 11-6660-204-10. A linearity calibration chart is shown at 1 in figure 80. The calibration chart is used to construct a correction chart which is shown at 2 in figure 80. This correction chart is posted at the radiosonde recorder as a convenient reference for the radiosonde recorder operator during the evaluation of the record. At the completion of the evaluation of the record, the linearity calibration chart (fig 80)

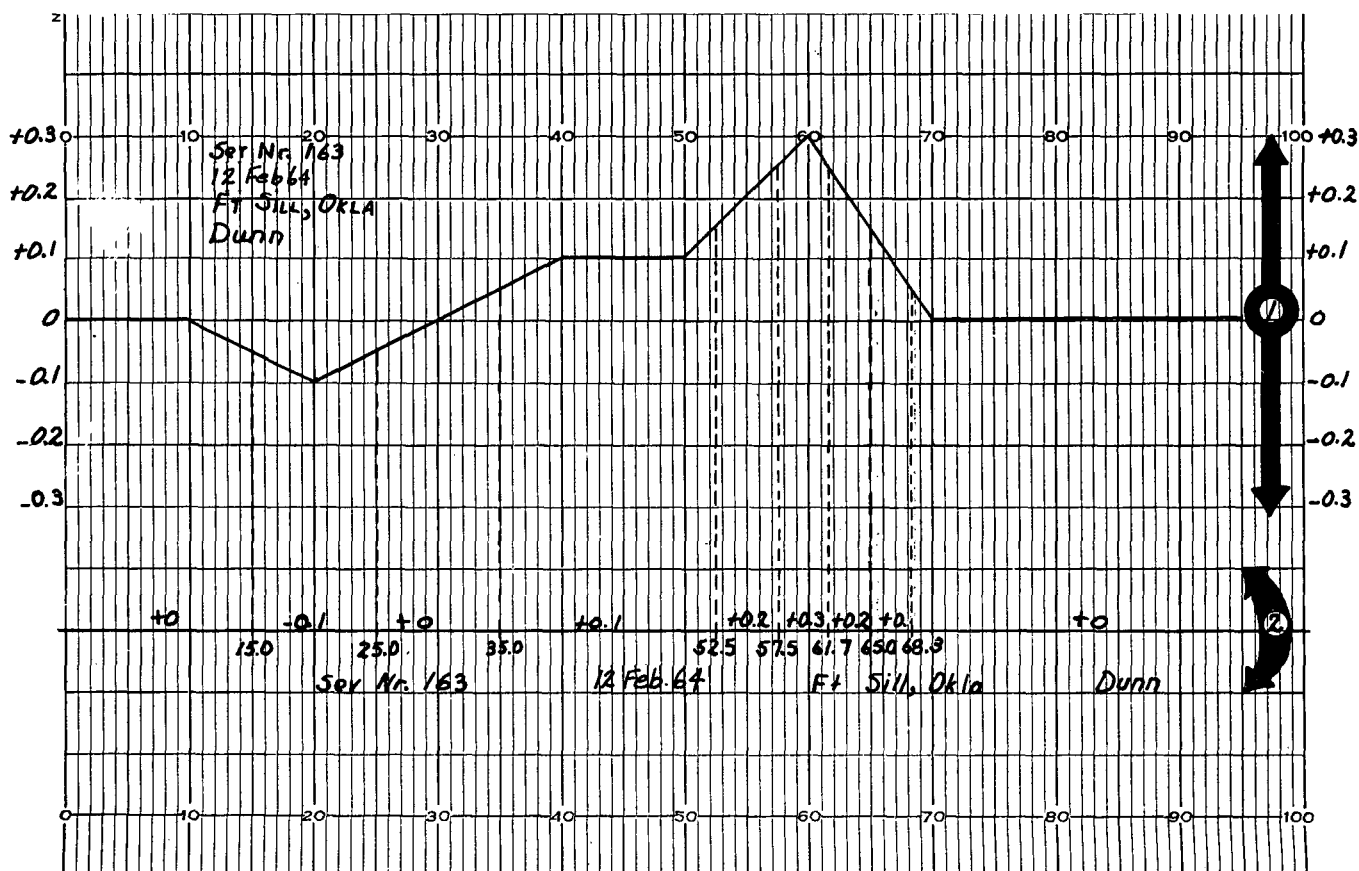

Figure 80. Recorder linearity calibration chart.

is inscribed at the bottom of each recorder record, during the period of its validity, for historical purposes. The calibration corrections are applied to all temperature recorder division values. Humidity recorder division values are corrected as specified in *i* below. To determine the correction for a particular recorder division value, the recorder operator enters the calibration correction chart and reads the correction to the nearest 0.1 recorder division. For example, for an uncorrected recorder division value of 37.0 (fig 80), the correction is +0.1 recorder division. This correction is applied to the recorder division value as described in paragraph 133g and as shown at 3 in figure 78.

c. Drift Correction. As a result of changes in battery voltages and resistances of the electrical components of the radiosonde, pulse frequency tends to drift. To compensate for this drift, the radiosonde recorder operator adjusts each low reference trace to 95 recorder divisions as it is printed on the recorder record. The corrections for the humidity and temperature recorder division values are determined according to the amount of the drift at the corrected low reference. The determination of the drift correction at any level is based on the assumption that the drift is linear between low reference traces except at the surface (*e* below). Figure 81 illustrates the procedure for determining drift corrections. The amount of drift from 95 recorder divisions is first determined at the top and bottom of each low reference trace (1, fig 81). A drift correction line (2, fig 81) is drawn from the bottom of the drifted low reference trace to the top of the previous low reference trace. The amount of drift between the two low reference traces is determined at the intersection of the significant level and the drift line. The difference between the recorder division value of the point of intersection and 95.0 recorder divisions represents the drift at 95.0. The drift correction (to the nearest 0.1 recorder division) is entered immediately above the level and left of the drift line (3, fig 81). Any recorder division value which is to be corrected at the level must be corrected by a proportionate part of the drift at 95.0 recorder divisions, since frequency drift is proportional to the frequency of the signal. This correction equals the recorder division value of temperature or humidity multiplied by the drift at 95.0 recorder divisions and divided by 95, the value of low reference. Determination of this correction is facilitated by use of the drift chart in figure 82. The radiosonde recorder operator may construct

a drift chart on a section of the recorder record. A horizontal line is selected as the base of the chart. Straight lines are drawn from the 0 recorder division point on the base to the points where the horizontal lines intersect the vertical line representing 95.0 recorder divisions. To the right of these points, the horizontal lines above the base are numbered in tenths from 0.1 to 1.0. To determine the drift correction, the chart is entered with the uncorrected recorder division value. This value is projected vertically to the diagonal line representing the amount of drift at 95.0 recorder divisions. From this point a line is projected horizontally to the correction scale on the right edge of the drift chart, and the drift correction is read to the nearest 0.1. As an example, for an uncorrected recorder division value of 60.8, the drift at 95.0 recorder divisions is determined to be +0.4. The drift chart (fig 82) is entered at the recorder division value of 60.8. This value is projected vertically to intersect the diagonal line labeled 0.4. From this point a line is projected horizontally to the correction scale, which indicates a correction of +0.3. The correction (+0.3) is the drift correction. The drift correction is applied to the recorder division value as described in paragraph 133g.

d. Frequency Shift Corrections. An instantaneous change of electrical response in the components of the radiosonde may create a frequency shift. A shift is apparent when there is an abrupt change in the recorder division value of a temperature, relative humidity, or reference trace.

Note. Changes in the positions of temperature and humidity traces resulting from the adjustment of a low reference trace to compensate for drift are not shifts.

Usually a shift will affect the frequency of all the recorded signals. When a shift occurs (1, fig 83), the radiosonde recorder operator *should not* make a correction with the reference adjust handwheel until a low reference trace is being printed. The low reference trace is adjusted to 95.0 recorder divisions (2, fig 83). This adjustment may compensate for drift (*c* above) in addition to the shift. A horizontal line is drawn to the right edge of the record. If the shift occurs during a temperature or humidity trace, the amount of shift at 95.0 recorder divisions must be computed based on the amount of shift occurring within the trace. The amount of shift is multiplied by 95 and the answer is divided by the recorder division value at which the shift occurred. The computations necessary to determine the amount of shift at 95.0 recorder divisions are shown at 3 in figure 83. When the adjustment of the low reference

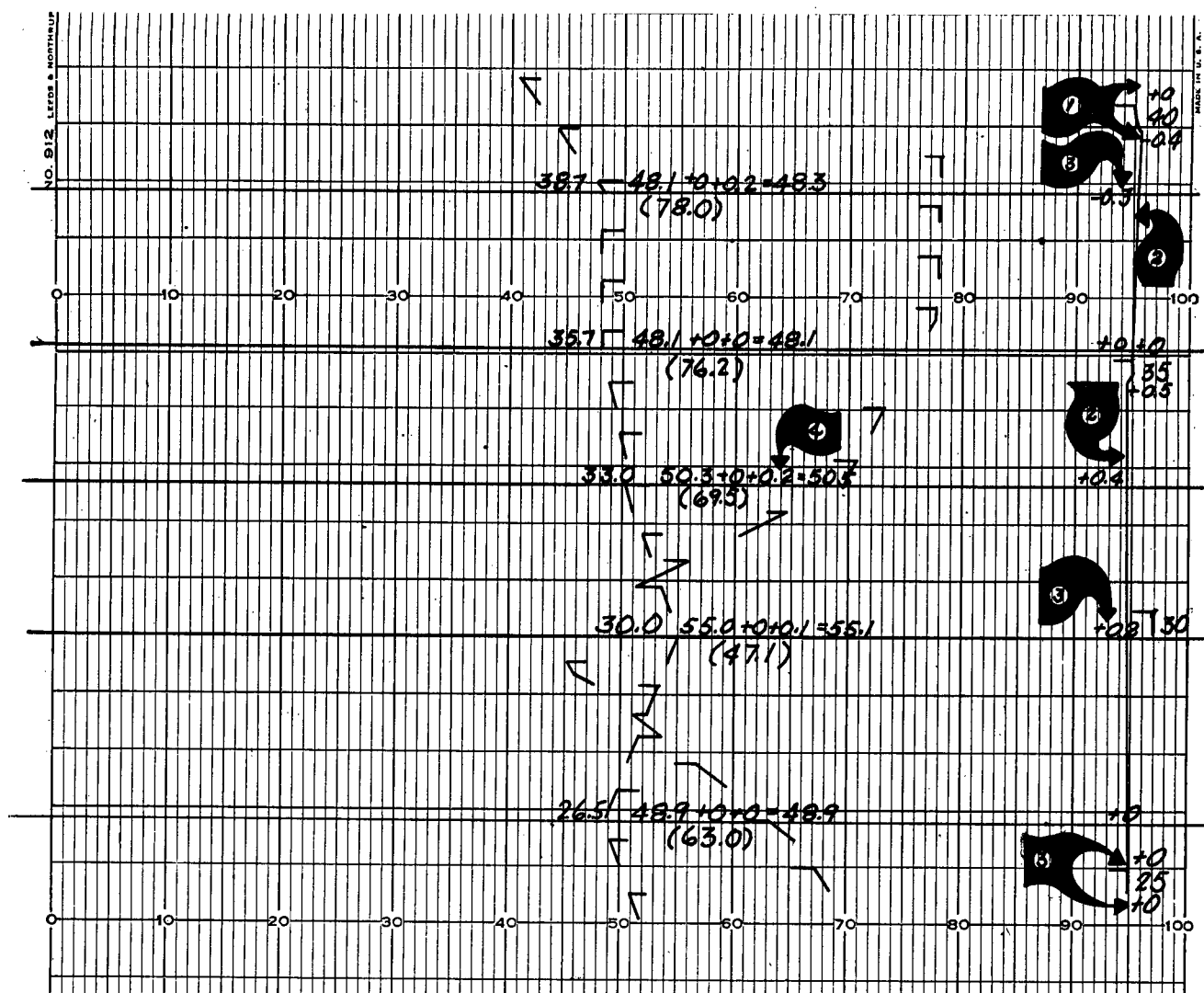

Figure 81. Frequency drift correction.

trace is greater or less than the shift computed for 95.0 recorder divisions, drift also has occurred. This condition exists at 4 in figure 82; in this case a drift correction line is constructed between the adjusted low reference trace and the preceding low reference trace. The computed shift at 95.0 recorder divisions is marked off at the beginning of the adjusted reference trace in the opposite direction of the shift (4, fig. 83). The drift line is drawn between this point and the top of the preceding low reference trace. The line at 5 in figure 83 that is broken above the shift and solid below the shift represents the drift that occurred between the two low reference traces. Only the drift correction (determined from the solid portion of the drift line) is applied to significant levels below the shift. Levels between the shift and the corrected low reference must be corrected for both drift and shift. A

shift plus drift correction line is constructed in this area. The computed shift at 95.0 recorder divisions is marked off in the direction of the shift, beginning at the intersection of the level of the shift and the drift line (6, fig. 83). The shift plus drift line is a solid line drawn from this point to the point where the corrected reference trace began. The intersection of this line with any significant level represents the shift plus drift correction at 95.0 recorder divisions for the level. The drift chart (fig. 82) is used to determine the proportional part of the shift plus drift correction which is applicable to any particular value of recorder divisions. The traces evaluated at level 3 in figure 83 are affected only by the drift measured at the intersection of the level and the drift line. The traces evaluated at level 4 are affected by both the shift and the drift measured at the intersection of the

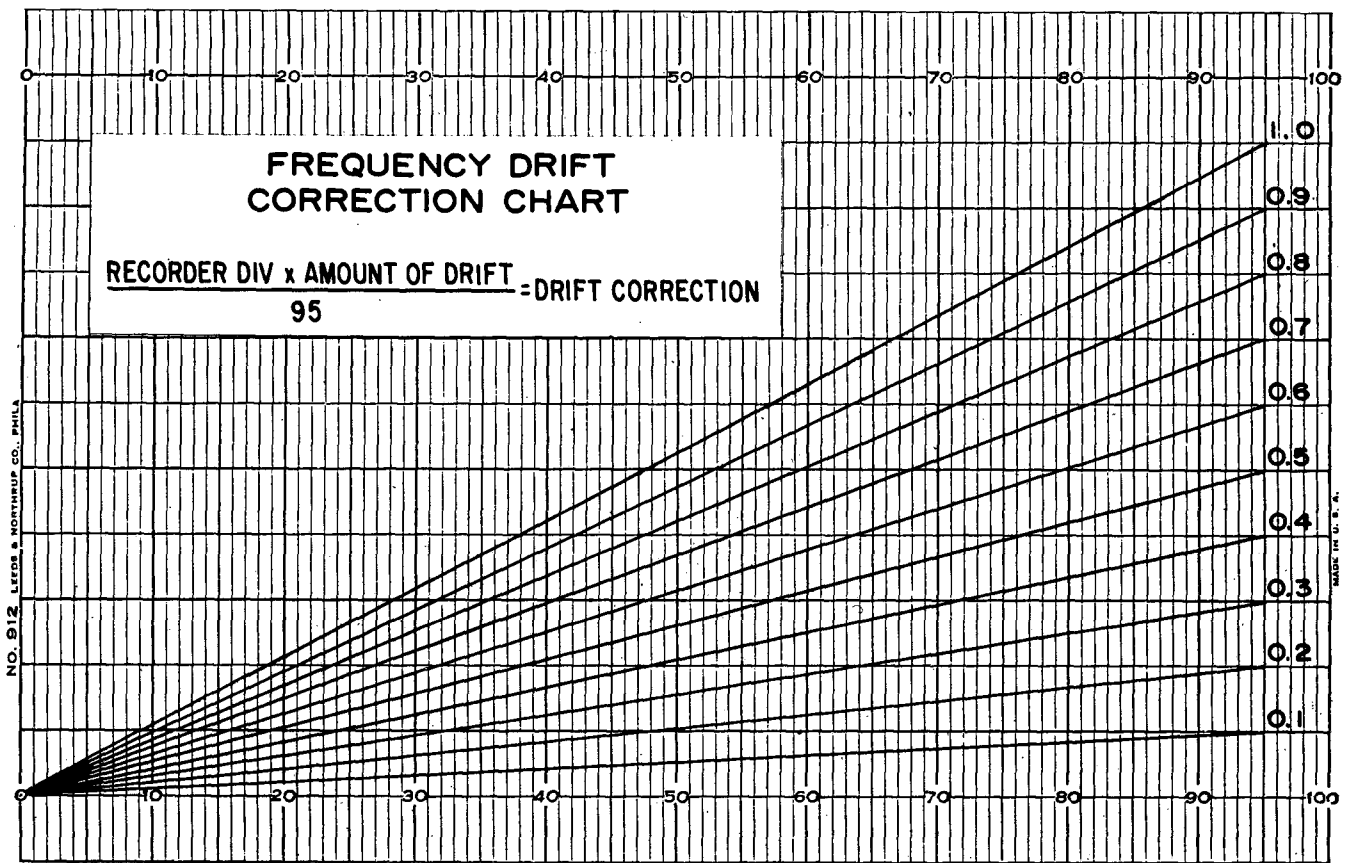

Figure 82. Use of the frequency drift chart.

level with the shift plus drift corrections to recorder division values as described in paragraph 133g.

★*e. Drift of First Low Reference Trace.* If a drift occurs in the first low reference trace after release it is corrected in the same manner as explained in *c* above. In the case of the first low reference trace after release, the drift line is drawn from the bottom of this trace to the top of the reference trace obtained during the reference-temperature-humidity check (para 114f).

f. Singular Shifts. When a shift occurs only in the temperature trace and is 1° C. or less as computed on the temperature-humidity computer, no correction is applied. If the temperature shift is more than 1° C. but not more than 3° C., a proportionate part of this shift must be applied to the recorder division values of temperatures at significant levels which follow. Temperatures which fall in this category will be classified as doubtful. If the shift occurs in temperature only and is more than 3° C., the temperatures are not evaluated beyond the shift and are classified as missing. When a shift occurs in relative humidity only and is 10 percent or less, no correction is

applied. However, if the relative humidity shift is greater than 10 percent, succeeding relative humidity values are classified as missing. Doubtful data may be used in the computation of a met message but are transmitted to the Air Weather Service (USAF) as missing. The accuracy of doubtful temperatures may be determined by comparing the current sounding with a recent scheduled flight no more than 6 hours old. The temperatures for several significant levels should reflect a high degree of consistency.

g. Correction for High Reference Trace Adjustment. Occasionally, the recorder operator may mistake a high reference trace for a low reference trace and adjust it to a value of 95.0 recorder divisions (1, fig. 84). This action causes a shift in the traces after adjustment. Any levels selected in this area (level 5, fig. 84) must be corrected for shift, as well as any drift that may have occurred. Levels selected in the area between the adjusted high reference and the preceding low reference (level 4, fig. 84) are not affected by the shift, but may be affected by the drift. The amount of drift must be determined. The first step in drawing the correction lines for these

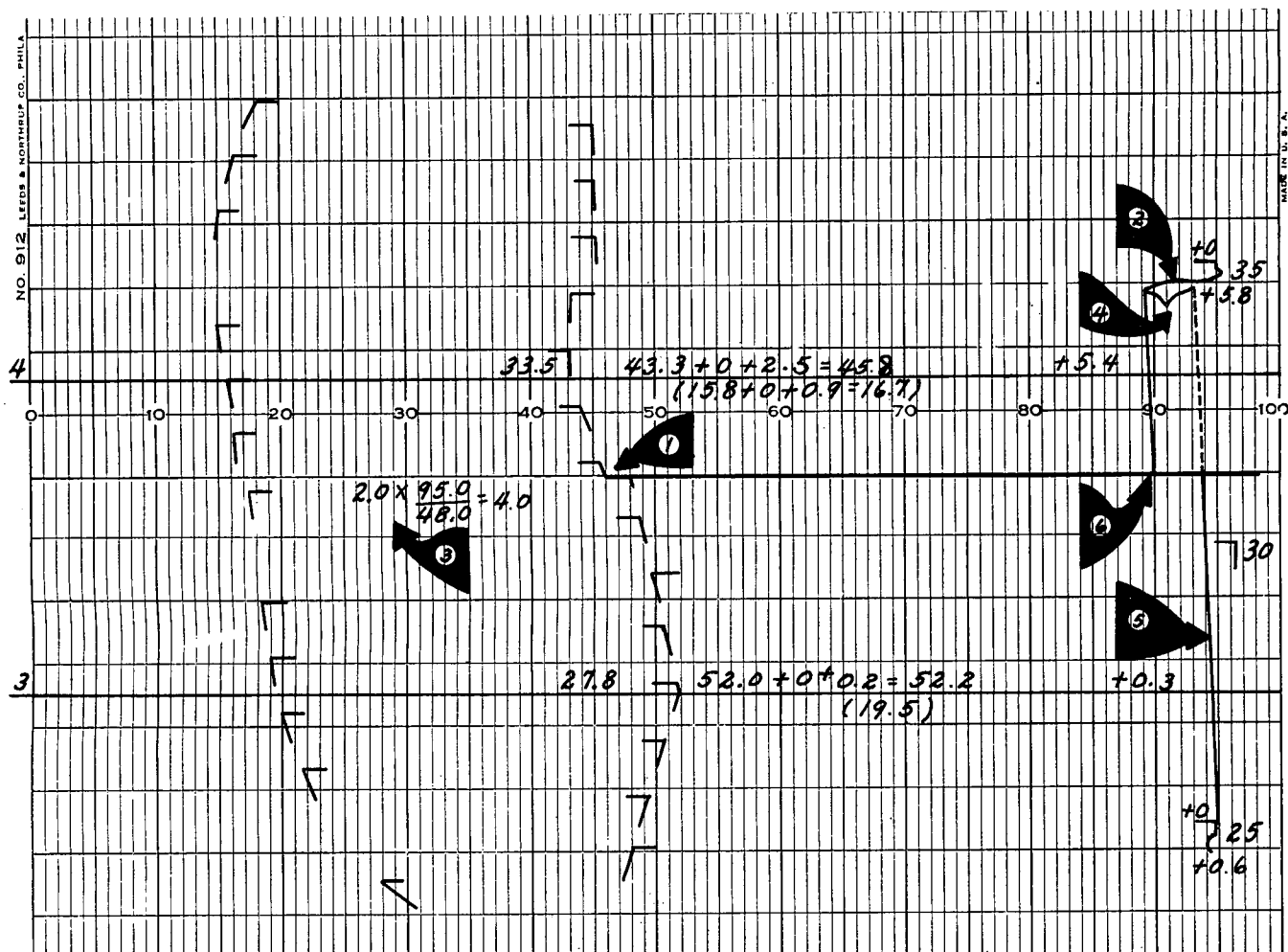

Figure 83. Determining shift or shift plus drift corrections.

areas is to measure the amount of shift resulting from the adjustment of the high reference trace to 95.0 recorder divisions. As measured at 1 in figure 84, the shift is 1.8 recorder divisions. The amount of this shift is marked off in the opposite direction of the shift at the beginning of the following low reference (2, fig 84). If the mark is not at 95.0 recorder divisions, drift (3, fig 84) has occurred in addition to the shift between the two low reference traces. A drift correction line is drawn from the mark to the top of the preceding low reference trace. This line is drawn as a broken line in the area above the shift and as a solid line in the area below the shift (4, fig 84). In the area where the drift line is broken the correction for the shift which affects the traces in this area must be added to the drift line to obtain the final shift plus drift correction line. To draw the shift plus drift correction line, the amount of the shift, 1.8 ordinates, from 95.0 recorder divisions at 1 in figure 84, is marked off in the direction of the ad-

justment, beginning at the intersection of the level of the shift and the drift line (5, fig 84). The shift plus drift correction line (6, fig 84) is drawn between this mark and the beginning of the corrected low reference trace. Temperature recorder division values for levels which intersect either of the solid correction lines are corrected with the drift chart (fig 82) as described in *c* above. Humidity recorder division values are corrected in the same manner as temperature values, but corrections to humidity values are applied only under the conditions specified in *i* below.

h. Chart Drift Correction. If the chart feed system of the radiosonde recorder is not properly aligned, the recorder chart may drift (fig 85). Drift is evident when the chart rides off the cogs of the chart roller. To avoid inaccuracies caused by chart drift and the difficulties of correction, the recorder operator should carefully align the chart during the starting procedure. Procedures for aligning the chart with the chart feed mecha-

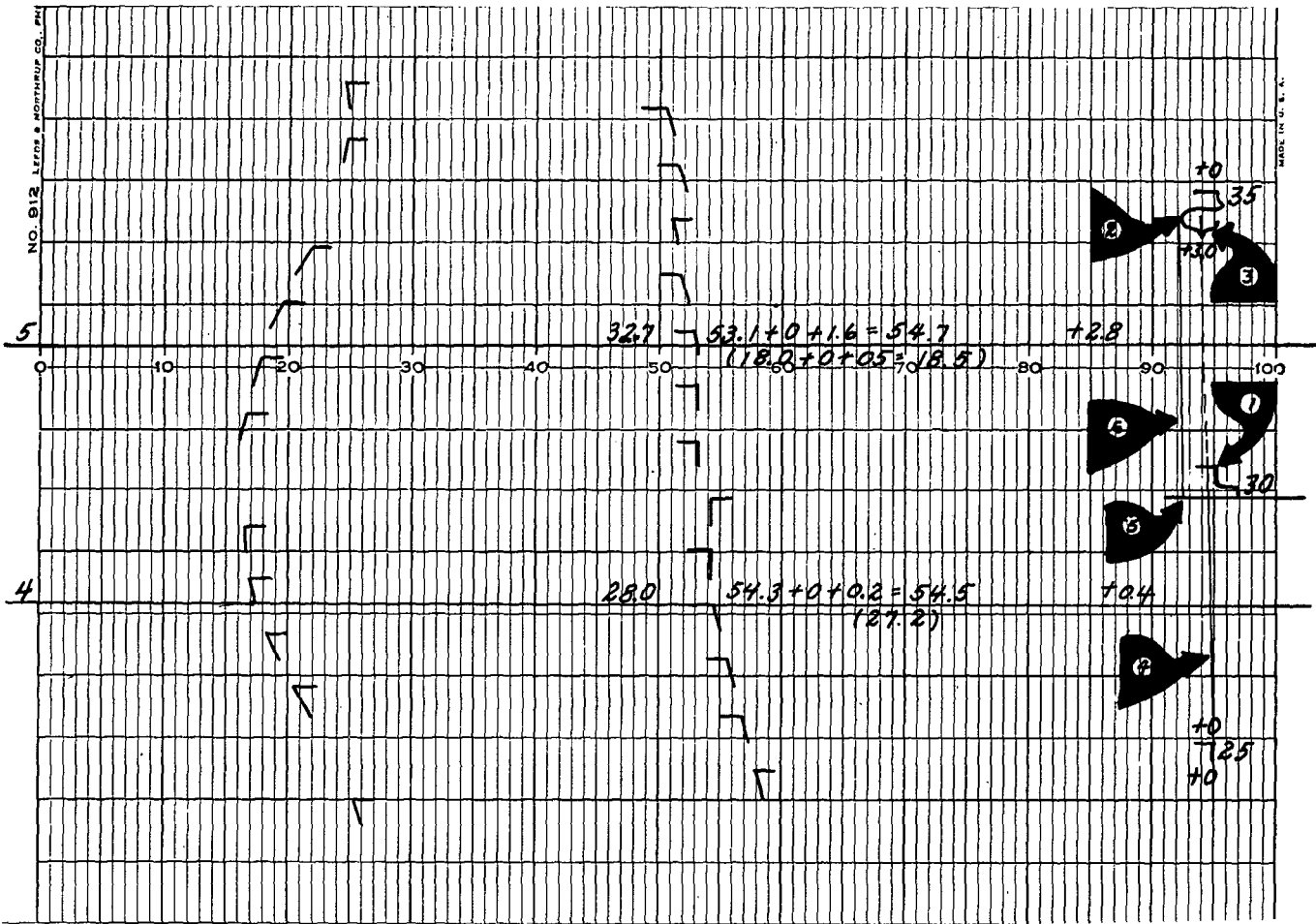

Figure 84. Determining corrections for high reference adjustment.

nism are outlined in TM 11-6660-204-10. If it appears that the chart is drifting while a flight is being recorded, the SIGNAL SELECTOR switch is rotated to the SC position for about 10 seconds to obtain a zero print (1, fig 85). This check is made at a point in the record where no significant data will be lost; e.g., during a high reference trace or a long temperature trace. During the remainder of the flight (or as long as the record continues to drift), a zero print may be obtained each time a high reference trace is transmitted by the radiosonde (2 and 3, fig 85). Successive zero prints are connected with a thin straight line (4, fig 85). The difference between the position of this chart drift line and the 0 recorder division line is the amount of the chart drift. After the chart drift lines are drawn, the chart drift correction at the 0 recorder division line is determined for any level selected during the periods of chart drift, and the amount of the correction is entered at the intersection of the level and the chart drift line (5, 6, and 7, fig 85). The correc-

tions for chart drift to be applied to ordinate values are computed as follows: Subtract from 95 (low reference ordinate value) the uncorrected temperature ordinate value, multiply the remainder by the chart drift correction at the given significant level, and divide the product by 95. The quotient is the required correction for that temperature ordinate. For example, if the temperature ordinate at a given level is 39.8 (8, fig 85) and the chart drift is +0.8 ordinates (6, fig 85), the correction is computed as follows:

$$95 - 39.8 = 55.2$$

$$\text{Therefore, } \frac{55.2 \times 0.8}{95} = +0.465$$

= +0.5 (rounded off to the nearest tenth), which is the required chart drift correction for the ordinate 39.8. This correction of +0.5 is entered at 9 in figure 85. The chart drift correction is read to the nearest 0.1 recorder division (0.5). A chart drift correction is applied to the temperature recorder division values when the chart drift is evaluated as 0.3 recorder divi-

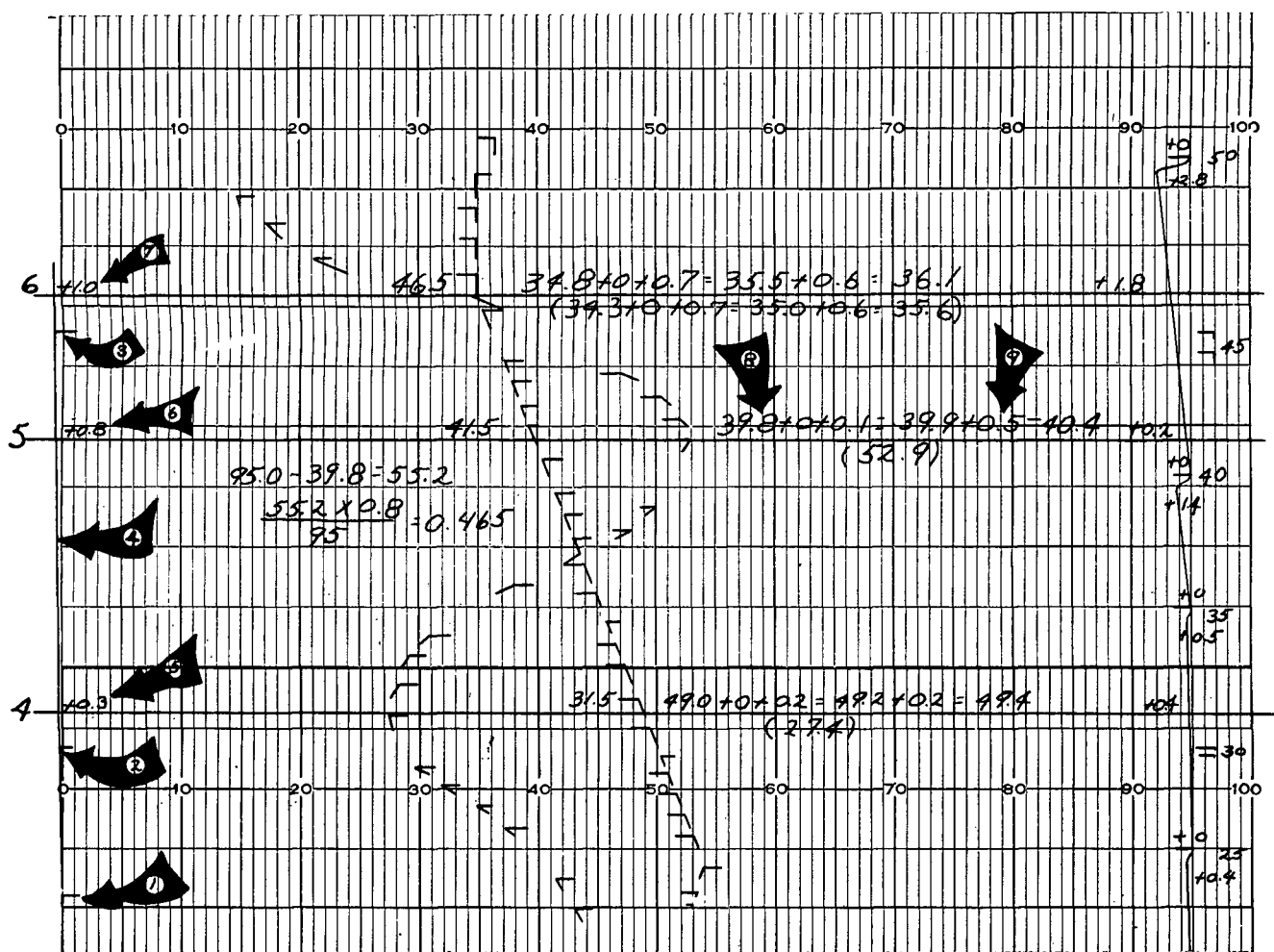

Figure 85. Determining chart drift corrections.

sions or more. The humidity recorder division value is corrected in the same manner as the temperature value, but the correction to a humidity value is applied only under the conditions specified in *i* below.

i. Correcting Humidity Recorder Division Values. Humidity recorder division values for any level, except levels selected in an area of chart drift, are corrected only when the total shift plus drift correction at 95.0 recorder divisions exceeds 1.0 recorder division for that level. The humidity recorder division value for a level selected in an area where chart drift has occurred is corrected when the algebraic sum of chart drift at the 0 recorder division and the shift plus drift correction at 95.0 recorder divisions exceeds 1.0 recorder division. The shift plus drift correction at 95.0 recorder divisions includes the effects (if any) of drift (*c* above), shift (*d* above), and high reference adjustments (*g* above). This correction is computed by determining the differ-

ence between the approximately constructed correction line (drift or shift line or a combination thereof) and 95.0 ordinates at the levels in question. The appropriate sign for the correction must also be determined as described for temperature in *c*, *d*, and *g*, above. When the shift plus drift correction at 95.0 recorder divisions plus chart drift at 0 is 1.0 or less, the uncorrected humidity recorder division value is entered in parentheses beneath the level (fig 83, level 4). If the shift plus drift correction at 95.0 recorder divisions plus chart drift at 0 exceeds 1.0 a recorder calibration correction (*b* above) and a shift plus drift correction (*c*, *d*, and *g* above) are applied to the uncorrected humidity recorder division value followed by application (if required) of a chart drift correction (*h* above) (fig 85, level 6).

135. Special Considerations

a. Leaking Aneroid Pressure Cell. Evidence that the aneroid pressure cell in the radiosonde is

leaking may be noted at pressures less than 100 mb. The traces will be unusually short and it will appear that an abnormally rapid ascension rate has developed. This condition will persist until the balloon bursts or until the pin arm leaves the commutator bar and a continuous temperature trace begins. In such cases, it is difficult to determine exactly where the pressure cell began to leak. Therefore, all data may be in error, and a second flight should be made. At pressures greater than 100 mb, short traces may result from an actual increase in the rate of ascension due to updrafts. In this instance, the traces will return to normal length when the balloon moves out of the area of ascending air currents. When balloon ML-541 is being used, unusually short traces may occur when the balloon attains high rates of rise due to the design characteristics. In this instance, traces will return to normal at high altitudes.

b. Termination Due to Doubtful or Missing Data.

(1) When a stratum of missing temperature data is followed by a satisfactory record, the computations are continued, if the missing data do not exceed—

(a) From the surface to 700 mb, 100 mb of missing data.

(b) From the surface to 400 mb, 250 mb of cumulative missing data, with (a) above satisfied.

(c) From the surface to 100 mb, 4 kilometers of cumulative missing data, with (a) and (b) above satisfied.

(d) From the surface to the termination of the flight, 5 kilometers of cumulative missing data, with (a), (b), and (c) above satisfied.

(2) When the tropopause occurs within a stratum of missing temperature data that is more than 1,500 meters thick, the flight will be terminated.

(3) When the missing data in one stratum exceed the limits in (1) above, computations are terminated at the base of the stratum. When the sum of the missing data through several layers exceeds the limits in (1) above, the computations are terminated at the base of the stratum in which the limit is exceeded (last usable trace). If the termination level does not meet the desired altitude, another release will be made with the least possible delay.

(4) When any portion of the temperature record cannot be clearly evaluated, the computations are continued in the normal manner except

that more than 100 mb of doubtful temperature data below 700 mb necessitates another release.

(5) As long as a stratum or strata of missing data does not exceed the above limits, the valid data are plotted on chart ML-574 and extrapolation is used in areas of missing data.

c. Icing. Icing causes a decrease in the ascension rate of the radiosonde balloon and is indicated by longer traces on the recorder record (1, fig 86). Since the ascension rate can be decreased by turbulence, as well as by icing, the temperature and relative humidity traces must be examined critically before assuming that icing occurred. When icing occurs, the length of the traces will increase as more and more ice accumulates on the balloon. Usually, these longer traces will not be apparent in less than four contacts. Before assuming that icing has occurred, the temperature should be below freezing and the relative humidity near 100 percent.

d. Floater. A floater is a radiosonde flight in which the balloon reaches an altitude and seems to maintain a fairly constant altitude. This floating may be caused by icing, turbulence, or a leaky balloon. A second release may be necessary. When it becomes apparent from the length of time the balloon stays in a floating state that it will not assume a normal rate of rise, as described in *c* above, preparations for a second release should be started.

e. Evaluation of Special and Significant Levels With the Hypsometer Radiosonde.

(1) *When to use the hypsometer pressure calibration chart.* The hypsometric pressure readings should be checked against the pressure capsule calibration chart readings between 50 and 20 mb. When the criteria set forth in paragraph 138i(4)(a) are obtained, the hypsometer readings and a hypsometer pressure calibration chart such as shown on 2, figure 60 are used to evaluate pressure.

(2) *Significant level evaluation.* When the hypsometer calibration chart is used to evaluate the pressures at significant levels, the recorder division value of the hypsometer line of linearity is evaluated at the point where the hypsometer trace (or extension thereof) intersects the significant level. The recorder division value is entered on the record to the left of the hypsometer trace (or extension thereof) and above the significant level (para 138).

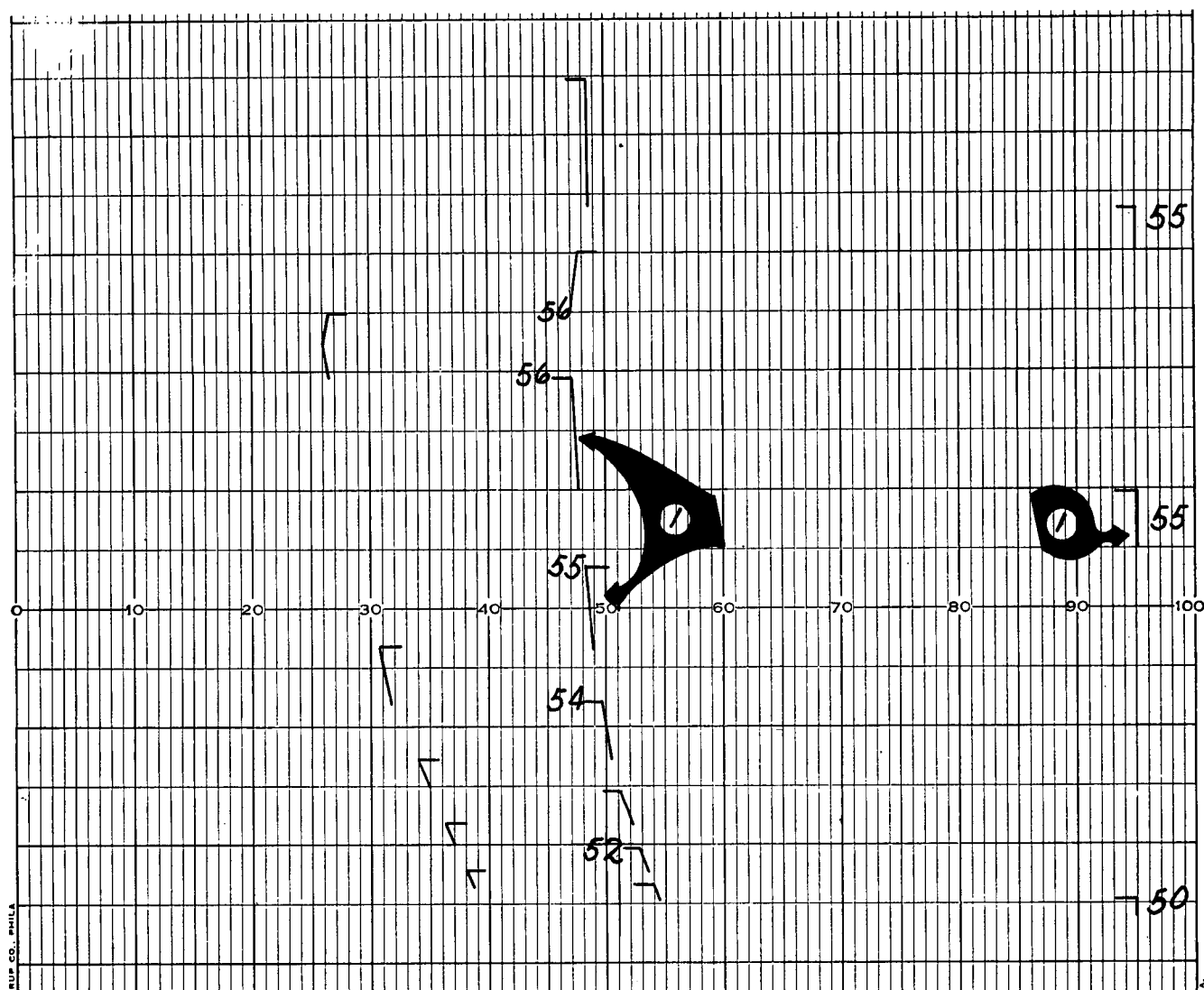

Figure 86. Icing.

136. Flight Duties of the Temperature-Density Plotter

The general duties of the temperature-density plotter during the radiosonde flight are to—

- Complete the surface observations and enter the results on DA Form 6-43 (Radiosonde Data).
- Plot the virtual temperature sounding curve on chart ML-574/UM using the data recorded on DA Form 6-43.
- Determine the mean zone densities and temperatures.

137. Flight Duties of the Temperature-Density Computer

The general duties of the temperature-density computer during the radiosonde flight are to—

- Determine the surface density and temperature in percent of standard.

- Obtain the zone temperatures and densities from chart ML-574/UM and compute the ballistic temperatures and densities.

- Assist and check the work of the temperature-density plotter.

138. Completion of DA Form 6-43, Radiosonde Data

The final step in evaluating a radiosonde recorder record is to complete DA Form 6-43 (fig 87). On this form are recorded the baseline check data, the release data, and the values of pressure, temperature, and relative humidity aloft. The station, location, date, release time, flight number, baroswitch serial number, name of computer, and name of checker are entered on the form. Data for figure 87 are obtained from figure 79.

RADIOSONDE DATA (FM 6-15)							
STATION		LOCATION		RE-LEASE TIME	DATE	HOUR	FLIGHT NO.
3D INF DIV ARTY		FTSILL, OKLA			LST	17 FEB 1964	
				GMT	17 FEB 1964	1730	
LEVEL NUMBER	PRESSURE		TEMPERATURE		RELATIVE HUMIDITY		
	CONTACT (1)	MILLIBARS (2)	RECORDER DIVISION (3)	°C (4)	RECORDER DIVISION (5)	% (6)	
BASE-LINE CHECK DATA	(INITIAL SETTING)	(INITIAL SETTING)	66.3	DRY	80.7	32	
	5.4	967		23.8			
				WET			14.0
RELEASE DATA	5.4	967	[REDACTED]	DEP'N	[REDACTED]	40	
				29.4			
				WET			—
SUR 0	[REDACTED]	967	69.1	DRY	78.5	40	
				29.4			
				WET			—
				DEP'N			
				—			
1	9.5	911	64.7	21.0	—	10	
2	13.0	862	60.8	14.5	—	10	
3	14.0	850	62.3	17.0	—	10	
4	16.0	822	65.8	23.0	—	10	
5	22.0	745	56.8	8.3	—	10	
6	25.8	700	56.8	8.3	—	10	
7	28.0	675	56.8	8.3	—	10	
8	32.0	630	53.6	3.7	80.5	33	
9	34.0	610	51.9	1.3	—	10	
10	45.0	500	43.0	-10.7	—	10	
11	56.5	400	33.6	-22.7	—	10	
12	60.0	373	30.8	-26.2	—	10	
13	XXX	XXX	XXX	XXX	XXX	XX	
14	70.5	300	22.4	-37.8	—	10	
15	72.0	288	21.0	-39.8	—	10	
16	78.0	250	19.5	-42.2	—	10	
17	87.2	200	16.7	-46.7	—	10	
18	97.5	150	11.0	-57.8	—	10	
19	100.0	140	9.5	-61.2	—	10	
20	105.0	120	8.7	-63.2	—	10	
21	107.0	113	10.5	-58.9	—	—	
22	110.9	100	9.0	-62.3	—	—	
23	120.0	73	9.8	-60.3	—	—	
24	128.4	50	9.1	-62.2	—	—	
25	133.0	38	10.5	-58.9	—	—	
26	136.2	30	9.5	-61.2	—	—	

DA FORM 6-43
1 MAR 62

PREVIOUS EDITION OF THIS FORM IS OBSOLETE.

Figure 87. DA Form 6-43 (Radiosonde Data).

RADIOSONDE DATA (Continued)						
LEVEL NUMBER	PRESSURE		TEMPERATURE		RELATIVE HUMIDITY	
	CONTACT (1)	MILLIBARS (2)	RECORDER DIVISION (3)	°C (4)	RECORDER DIVISION (5)	% (6)
27	137.0	28	9.0	-62.3	—	—
28	140.2	21	13.0	-53.5	—	—
29	142.0	16	12.3	-55.0	—	—
30	145.0	10	16.9	-46.3	—	—
31						
32						
33						
34						
35						
36						
37						
38						
39						
40						
41						
42						
43						
44						
45						
46						
47						
48						
49						
50						
51						
52						
53						
54						
55						
56						
57						
58						
59						
(7) MODULATOR SERIAL NO. 696900	BASELINE CHECK TIME LST 1125 GMT 1725		RECORDER OPERATOR DUNN		CHECKER SCHEIRER	

U.S. GOVERNMENT PRINTING OFFICE : 1962 O-638174

Figure 87—Continued.

a. Baseline Check Data. The following data from the baseline check observations are entered on DA Form 6-43 (fig 87) in the spaces opposite the words BASELINE CHECK DATA:

(1) *Column 1.* The contact setting (5.4) for the barometric pressure of the station, as determined from the radiosonde pressure calibration chart.

(2) *Column 2.* The barometric pressure in millibars (967) used to determine the correct pin arm setting.

(3) *Column 3.* The recorder division value of temperature (66.3) as evaluated from the baseline check.

(4) *Column 4.* The dry-bulb temperature in degrees Celsius (23.8), as observed inside the baseline check set; the wet-bulb temperature in degrees Celsius (14.0), as observed inside the baseline check set; and the wet-bulb depression in degrees Celsius (9.8).

(5) *Column 5.* The recorder division value of humidity traces (80.7) as evaluated from the baseline check.

(6) *Column 6.* The percent of relative humidity (32) inside the baseline check set chamber, as determined by entering chart VIII, FM 6-16, with the dry-bulb temperature and the wet-bulb depression to the nearest 0.1° C. (in column 4) as arguments.

b. Release Data. The following data from the surface observations are entered on DA Form 6-43 (fig 87) in the spaces opposite the words RELEASE DATA:

(1) *Column 1.* The contact number (5.4) corresponding to the surface barometric pressure at release.

(2) *Column 2.* The barometric pressure in millibars (967) at the time of release.

(3) *Column 4.* The air temperature in degrees Celsius (29.4) at the time of the Reference-Temperature-Humidity check.

(4) *Column 6.* The percent of relative humidity (40) in the atmosphere as determined during the Reference-Temperature-Humidity check.

c. Surface Level. The pressure, air temperature, and relative humidity values entered opposite the word SUR (surface) are the same as those entered opposite RELEASE DATA. The recorder division values corresponding to the surface temperature and humidity are recorded in the appropriate blocks.

d. Pressures Aloft. In column 1 (fig 87), the corrected contact number for each significant level on the recorder record is entered opposite the level number. In column 2, the pressure in

millibars is entered. The pressure for each level is obtained from the appropriate pressure calibration chart, which is entered with the correct contact number (column 1).

e. Temperatures Aloft. In Column 3, the corrected recorder division value of temperature for each level on the recorder record is entered opposite the corresponding level number. The humidity-temperature computer is used to convert the recorder division values to temperatures to the nearest 0.1° C. These temperatures are entered in column 4.

f. Relative Humidities Aloft. In column 5, the recorder division value of humidity (corrected if necessary) for each level on the recorder record is entered opposite the level number. The humidity-temperature computer is used to convert the recorder division values to percent of relative humidity. The temperature in column 4 for each level is used to determine the value of relative humidity which is entered in column 6, opposite the corresponding recorder divisions. Humidities for levels aloft should be read from the computer to the nearest whole percent.

g. Doubtful Data. Doubtful data are indicated with an asterisk on the data sheet.

h. Missing Data. Missing data are indicated with "X's" on the data sheet (level 13, fig 87).

i. Hypsometer Pressure Evaluation.

(1) Pressure contact values for radiosonde AN/AMT-12 are evaluated in the same manner as those for radiosonde AN/AMT-4() up to the level where the hypsometer becomes usable. The hypsometer circuit starts with contact 106 and replaces the low reference contact before and after each high reference contact above 105. For example, contacts 106, 109, 111, 114, and 116 are hypsometer contacts. In addition, contact 148 is used because of the small pressure change.

Note. The hypsometer will trace out a continuous curve (when individual traces are connected) which trends toward the left. Therefore, pressures can be evaluated at any level; not merely at the top or bottom of a trace. When the flight ends on a temperature trace, the trend of the hypsometer trace will be extrapolated upward to the terminal level. After the balloon bursts, the hypsometer trace will change direction and trend toward the right, however, pressure values are not valid during the descending portion.

(2) After the baseline check of the radiosonde AN/AMT-12 has been computed, the radiosonde is removed from the baseline check set and the pin arm is raised off the commutator. The black test lead protruding from the right side of the case is touched to the eyelet on the extreme

right of the commutator. This contact should energize the hypsometer relay and connect the hypsometer into the circuit. When the contact is grounded, the reading on the recorder should be about 93 ordinates. If the reading is 95 ordinates or more, the hypsometer circuit is shorted; the modulator should be replaced and a new baseline check performed. Modulators rejected because of defective hypsometers may still be used for soundings in which high-altitude data are not required. The hypsometer is disabled by disconnecting and soldering together the leads to the capsule. The pressure information obtained with a radiosonde AN/AMT-12 that has a disabled hypsometer will be the same as that obtained with a radiosonde AN/AMT-4.

(3) After the baseline and hypsometer have been checked and the pin arm has been set, 5 cubic centimeters (cc) of carbon disulfide (CS₂, reagent grade) are inserted in the hypsometer boiler. The radiosonde should be held upright until it is launched to prevent the fluid from spilling.

Warning: (a) Carbon disulfide is poisonous, highly flammable, and explosive under certain conditions. Personnel should exercise extreme caution in the storage and handling of the material.

(b) Both the liquid and the vapor are highly toxic. Do not open containers where there is inadequate ventilation. Preferably containers should be opened outdoors. Do not inhale fumes. In the pure state carbon disulfide is relatively odorless; therefore, one must not rely upon odor to indicate the presence of the chemical vapor. Avoid contact of the liquid with the skin or eyes; in case of accidental contact, wash the affected area immediately with water. The poisonous effects of the chemical may be cumulative; therefore, repeated exposure in small doses may be as hazardous as a single dose.

(c) Since carbon disulfide is highly flammable, do not permit anyone to smoke around open containers. Keep fluid away from heated surfaces, from flames or smoldering fires, and from sparks, such as those generated by exposed electric switches or by open motor commutators. Spontaneous ignition will occur at 212° F. In case of fire, extinguish blaze with sand, earth, water, carbon dioxide, or dry chemical fire extinguishers.

(d) The substance will explode when subjected to high heat, high pressure, or concussion. In addition to the precautions listed above, use care to avoid spilling the liquid. In

the event of accidental spillage, avoid stepping in the liquid. Flush the affected area immediately with water. Do not permit cotton, rags, or waste saturated with carbon disulfide to accumulate; such material should be soaked with water before disposal.

(e) Carbon disulfide is supplied in sealed ampoules each containing about five cubic centimeters of the chemical. Do not drop, toss, throw, or unnecessarily shake the ampoules, as the resulting jar might set off a damaging explosion. Similar precautions should be exercised in handling used ampoules, as there may be sufficient liquid adhering to the inside of the vessel to explode. Used ampoules should be placed in a protected place outdoors until all liquid adhering to the inside has evaporated, after which they may be discarded as trash.

(4) The hypsometer calibration chart is a curve of pressure versus hypsometer ordinate divisions as traced on the recorder record. The hypsometer trace for the AN/AMT-12 radiosonde first appears on the recorder record during flight at about 90 ordinates and moves towards lower ordinate values with decreasing pressure. When the AN/AMT-12 radiosonde is used, pressures will be determined from the pressure capsule calibration chart until the difference between the pressures thus obtained and the pressures obtained from the hypsometer calibration chart reaches a point of least difference in the 50 to 20 millibar range. When the least pressure difference exceeds four mb, computations will be terminated at 50 mb as this magnitude of difference indicates a pressure error which is unacceptable at pressures below 50 mb. When computations are terminated at 50 mb, a second release will be made if the minimum height requirement has not been attained. When the least pressure difference is four mb or less, the pressures for each significant level will be determined from the hypsometer calibration chart by using the corrected hypsometer ordinate values to the nearest tenth of a division. Pressures obtained from the hypsometer calibration chart will be read to the nearest millibar at pressures equal to or greater than 20 mb and to the nearest tenth of a millibar at pressures lower than 20 mb as 9.6, 5.4, etc. Significant errors in radiosonde and rawin data can result in the area where switchover from aneroid to hypsometer pressure values occurs. Consequently, the following procedures will be used to minimize these errors.

(a) Select the point between 50 and 20 mb on the hypsometer trace where the pressure

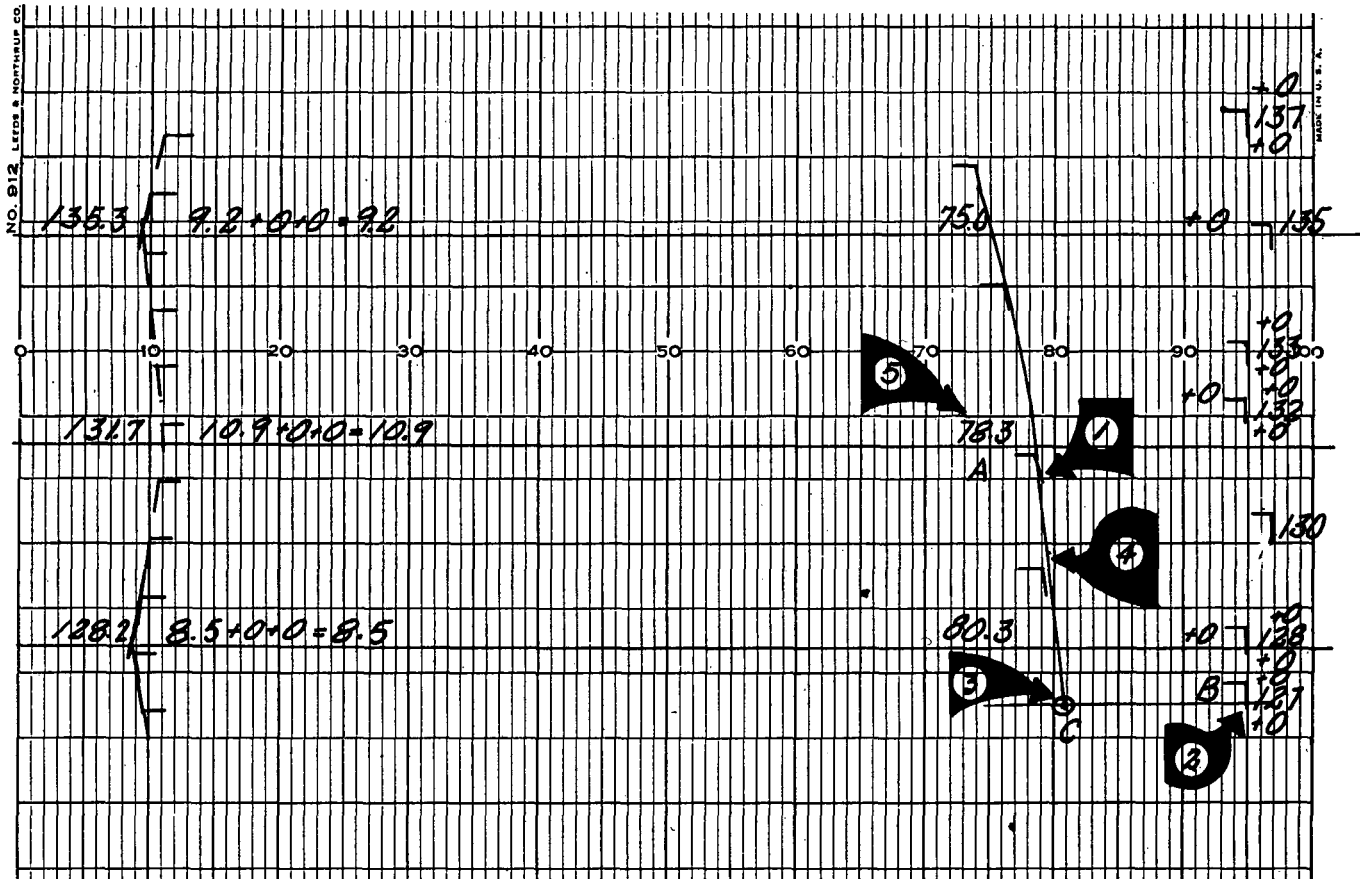

Figure 88. Hypsometer pressure evaluation.

difference between hypsometer and aneroid is smallest and four millibars or less. Label this point A (1, fig. 88). If the pressure difference is less than 1 mb, use the hypsometer pressures (as shown at 5, fig. 88) from point A on, and disregard the following subparagraphs.

(b) Locate the draw a horizontal line at the level where the number of minutes below point A is equal to two times the pressure difference at point A. Label the point of intersection of this line with the 95th recorder division as "B" (2, fig. 88).

(c) Use the aneroid calibration chart to obtain the pressure corresponding to the aneroid pressure contact value at point B. Convert the millibars of pressure obtained to recorder divisions by using the hypsometer calibration chart.

(d) On the recorder record, plot the recorder divisions derived in step (c) on the horizontal line through point B. Label this plot as point C (3, fig. 88). Connect points A and C with a straight line (4, fig. 88).

(e) Compute and use the hypsometer

pressures for all significant levels falling between points A and C by using line AC as the hypsometer pressure curve.

Figure 89. Chart ML-574.
(Located in back of manual)

Figure 89—Continued.
(Located in back of manual)

139. Determining Mean Zone Densities and Temperatures From Radiosonde Data

★a. *Plotting Data on Chart ML-574.* The significant level data recorded on DA Form 6-43 (fig. 87) are used to plot points on chart ML-574 (fig. 89) so that the upper air densities, pressures, and temperatures may be determined graphically from a sounding curve. Chart ML-574 is constructed so that, in any part of the chart, the difference in height between two pressure values is proportional to the distances between the isobars representing those pressure values, provided the distance is measured along the isotherm representing the mean virtual tem-

perature of the layer of air. This distance is measured with a zone-height scale ML-573 (fig. 90), which is graduated in meters and which also indicates the thickness of artillery standard zones. Artillery met sections ordinarily use only the zone portion of the scale. On this scale, the distance between the unnumbered graduations is equal to the thickness of the zone. The number of the zone appears opposite the intermediate graduation at midpoint of the zone. The intermediate graduations are labeled with the numbers of all the zones to which they apply.

b. Description of Chart ML-574.

(1) Chart ML-574 (fig. 89) contains four sets of lines which are—

(a) Orange vertical lines of constant temperature (isotherms) graduated in degrees Celsius.

(b) Orange constant pressure lines (isobars) sloping slightly upward from left to right.

★(c) Short, blue, vertical lines, or hatchings, along certain isobars.

(d) Blue lines of constant density, curving downward from left to right and labeled in grams per cubic meter (Gm/M³).

(2) The chart is presented in two parts—a high pressure part on the front side (fig. 89) and a low pressure part on the reverse side (fig. 89).

(3) The chart is a graphical solution of the hydrostatic equation and the equation of state.

★*c. Plotting Significant Data on Chart ML-574.*

The radiosonde data recorded on the DA Form 6-43 (temperature, pressure, and relative humidity) for each significant level are used to plot significant points on the sounding curve. Successive significant points are then connected with straight lines to produce the virtual temperature sounding curve. The size of the chart permits the plotting of the sounding curve in successive legs in order to obtain the data for all met messages. Each significant point used to construct the sounding curve is located by a value of pressure and a value of virtual temperature. Tabular values or multipliers in table If, FM 6-16, indicate how much greater the virtual temperature is than the observed temperature in that region of the chart, when the relative humidity is 100 percent. Virtual temperature for each point is derived by multiplying the relative humidity decimal value by the temperature multiplier and algebraically adding the resultant correction factor, rounded off to the nearest 0.1° C., to the observed air temperature. The temperature multiplier is determined by entering table If, FM 6-16, with the observed air temperature rounded off to the

nearest whole degree Celsius, and the observed pressure, rounded off to the nearest fifty millibars. If the observed pressure value ends with 25 or 75, e.g.; 775, etc., round off to the lower 50 millibar value before entering the table. Figure 91 shows a virtual temperature plot of a significant point based on the following data:

Pressure 557 mb
Temperature -5.7° C.
Relative Humidity 48 percent.

★*d. Procedure.* First, the point is plotted at the pressure of 557 mb and the actual temperature of -5.7° C. Next, enter table If, FM 6-16, with pressure and temperature values rounded off as described in *c* above (550 mb and -6° C.) and determine the temperature multiplier (0.7° C.). Since the relative humidity is 48 percent, the correction to be applied to the actual temperature of the point is $0.48 \times 0.7^\circ \text{C.} = 0.3^\circ \text{C.}$ (rounded off to the nearest 0.1° C.). The virtual temperature plot is then located at a temperature of -5.4° C. ($-5.7 + 0.3 = -5.4$) and a pressure of 557 mb. It is this final point, corrected for the relative humidity, which is used in constructing the sounding curve.

e. Plotting the First Leg of the Sounding Curve. The pressure scale on the right-hand edge of the chart is used for plotting significant points of pressure from 1050 mb up to approximately 300 mb. When all the significant levels from the surface up to a pressure of about 300 mb have been plotted, straight lines are drawn to connect successive plotted points. The resulting line is called the first leg of the sounding curve. This leg of the sounding curve should be evaluated as soon as enough data is available to include zone one before further points are plotted in order to furnish data to the winds team. The base of the sounding curve is plotted by drawing an isobar through the first significant point plotted (surface) and parallel to the nearest printed isobar on the chart.

f. Plotting the Second Leg of the Sounding Curve. The plot of the second leg is initiated by replotting the point at which the first leg of the sounding curve intersects the line that represents the top of the last zone evaluated (fig. 89). This point is replotted at the bottom of the chart by using the same temperature scale used to plot the first leg; however, the pressure scale on the *left-hand* edge of the chart is used. Then, all significant points between the pressure corresponding to the replotted point and a pressure of approximately 150 mb are plotted and connected with

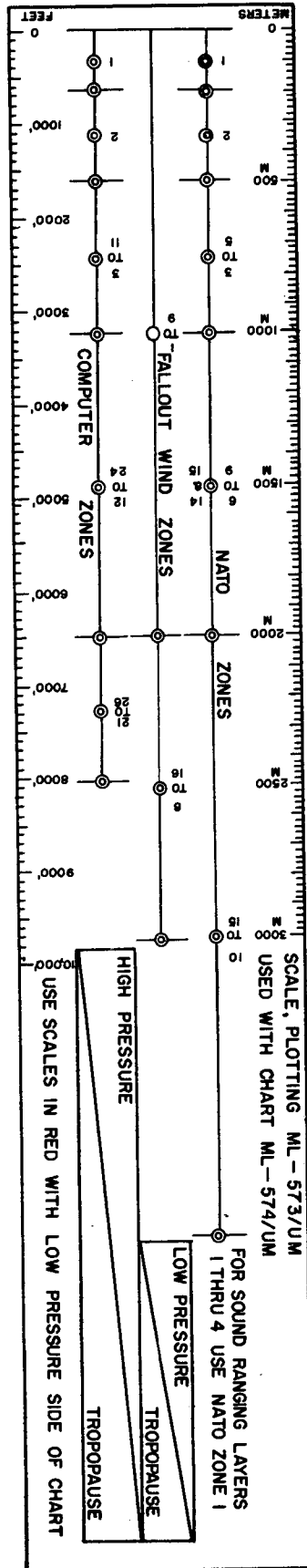
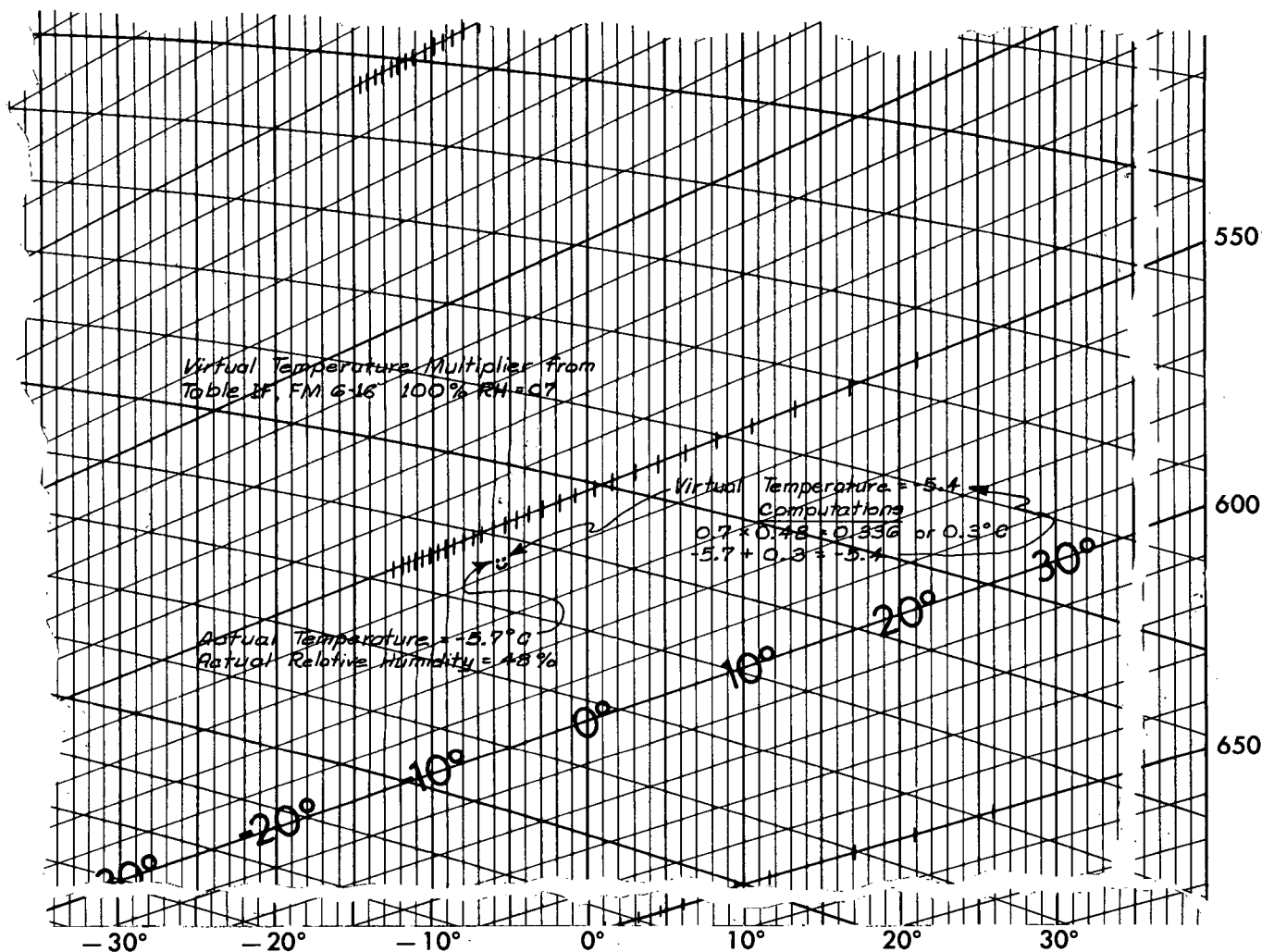

Figure 90. Zone height scale ML-573.



★Figure 91. Virtual temperature plot of a significant point.

straight lines. Points plotted on the first leg which lie above the top of the last zone considered on the first leg must be replotted on the second leg.

g. Plotting the Third Leg of the Sounding Curve. The plot of the third leg is initiated by replotting the point at which the second leg of the sounding curve intersects the line representing the top of the last zone evaluated (fig. 89). The temperature (-59.9) and the pressure (143 mb) of the point of intersection are read on the temperature scale and the pressure scale on the left edge of the chart. The pressure (143 mb) is multiplied by 2 (286 mb). The original temperature and the doubled pressure are used to replot the point on the chart by using the same temperature and pressure scales. This replotted point is the first plot for the third leg. The pressure of all

significant points between the pressure corresponding to the replotted pressure (143 mb before it is doubled) and approximately 65 mb are multiplied by two, plotted, and connected by straight lines. The third leg includes those points plotted above the top of the last zone evaluated on the second leg. Actual pressures along the third leg are obtained by dividing by two the pressure reading along the left hand edge.

h. Plotting the Fourth Leg of the Sounding Curve. When a fourth leg of the sounding curve is required to complete a requirement, the plotting is continued on the low-pressure side of chart ML-574 (fig. 89). The procedure is the same as that outlined for the first leg on the high-pressure side. Additional legs may be plotted as required on the low-pressure side of chart ML-574 by using the same procedures out-

lined for the corresponding legs on the high-pressure side.

140. Balancing Areas on Chart ML-574

a. General. After the virtual temperature sounding curve have been plotted, the next step is to scale off the zones on the sounding curve. The zoning is accomplished by using the computer zones on scale ML-573. In scaling zones on the chart, it is necessary that the scaling be done on an isothermal line that is the average virtual temperature of the zone being scaled. The determination of the average temperature in a zone is accomplished graphically and visually with scale ML-573. The procedure is to balance the areas delineated by the sounding curve, the isobars bounding the zone and the vertical line of the computer zone scale. The procedure is described in detail in *b* below.

★*b. Straight Line Curve.* Scale ML-573 is oriented so that the point on the scale representing the base of computer zone one lies on the surface isobar and the vertical line of the scale is parallel to the isotherms. Then the scale is shifted laterally along the isobars, maintaining the proper isotherm orientation, until the area to the left of the vertical line on the scale equals the area to the right of the vertical line. For example, the shaded area (1, fig. 92) which is bounded by the vertical line of the scale (2, fig. 92), the sounding curve (3, fig. 92), and the isobar passing through the top of zone 1 (4, fig. 92) equals the shaded area (5, fig. 92) which is bounded by the vertical line of the scale, the sounding curve, and the isobar passing through the bottom of zone 1 (6, fig. 92). When the areas are balanced, the vertical line of the scale lies along an isotherm, which is the mean (average) virtual temperature of the zone, and the mean density and pressure of the zone is at the zone midpoint. If the sounding curve appears as one straight line between the top and bottom of any zone, as shown in figure 92, the areas are balanced when the zone midpoint graduation on the scale falls directly on the sounding curve. After the areas are balanced, the zone midpoint (7, fig. 92) and the top of zone 1 (8, fig. 92) are marked on the chart at the appropriate graduations on the scale. The midpoint of zone 1 is circled and evaluated for temperature and pressure/density, and the zone number is entered just to the left of the circle. A solid line is drawn through the point at the top of zone one and parallel to the isobar nearest the point. This line represents the pressure at

the top of zone 1 and the pressure at the bottom of zone 2. Zone 2 is balanced in the same manner as zone 1. The scale is oriented so that the graduation representing the base of zone 2 lies on the isobar drawn through the top of zone 1 (which represents the base of zone 2 on the chart) and so that the vertical line of the scale is parallel to the printed isotherms. The pertinent areas are balanced by laterally shifting the scale as described above. (Balancing of areas other than the straight line type is covered in *c* below.) When the zone areas are balanced, the midpoint and top of zone 2 are marked on the chart. As before, the top of the zone is indicated by a line parallel to the isobar nearest the top of the zone. The midpoint is circled and numbered (to the left) and evaluated for temperature and pressure/density. The same procedure is carried out for the remaining zones. When the upper limit of a zone lies above the top of the first leg, this zone is evaluated starting at the bottom of the second leg.

c. Balancing Irregular Areas. The most simple case of balancing areas is shown in figure 92, where the curve appears as one straight line between the top and bottom of the zone. When the sounding curve does not follow a straight line, irregular areas are formed, and, in certain instances, three or more areas will have to be balanced. In all situations, all of the areas which appear to the left of the vertical line of the scale must balance all the area that appear to the right of the vertical line. When the areas are properly balanced (area 1 equals area 2, fig. 93 ①), the midpoint of the zone (3, fig. 93) may not fall on the curve (4, fig. 93). Figure 93 ② shows three areas to be balanced. The sum of the two shaded areas which fall to the right (1 and 2, fig. 93 ②) is balanced against the shaded area which falls to the left (3, fig. 93 ②). Although in this example the midpoint of the zone (4, fig. 93 ②) does not fall on the curve (5, fig. 93 ②), it is possible for it to do so. On this type curve the point will normally fall to the left or right, depending on the configuration of the sounding curve. Two important requirements must be fulfilled in moving the scale laterally across the chart to balance the areas for any zone. First, the graduation of the scale representing the bottom of the zone must be kept on the line of constant pressure which represents the bottom of the zone; second, the vertical line of the scale must be kept parallel to the printed isotherms.

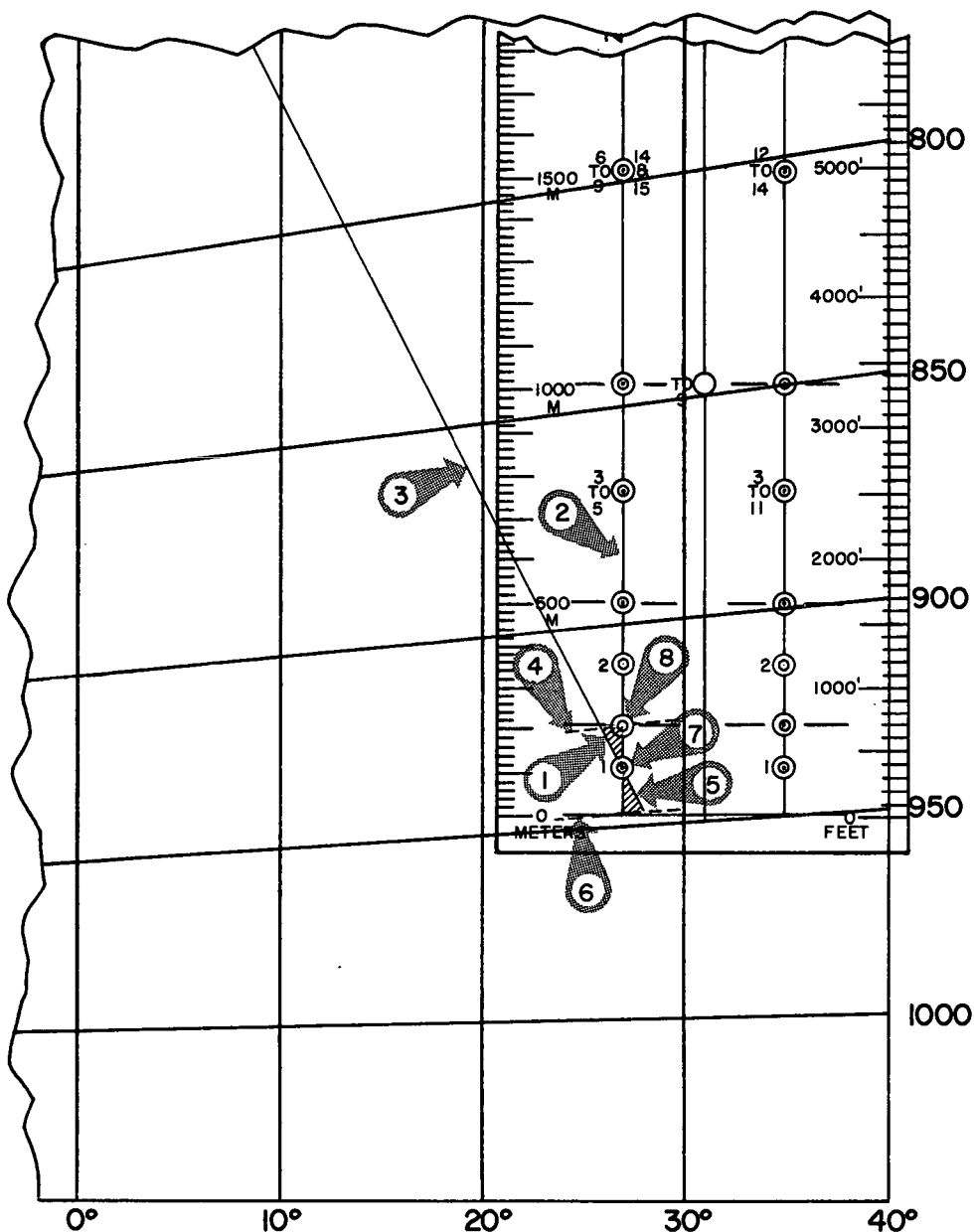
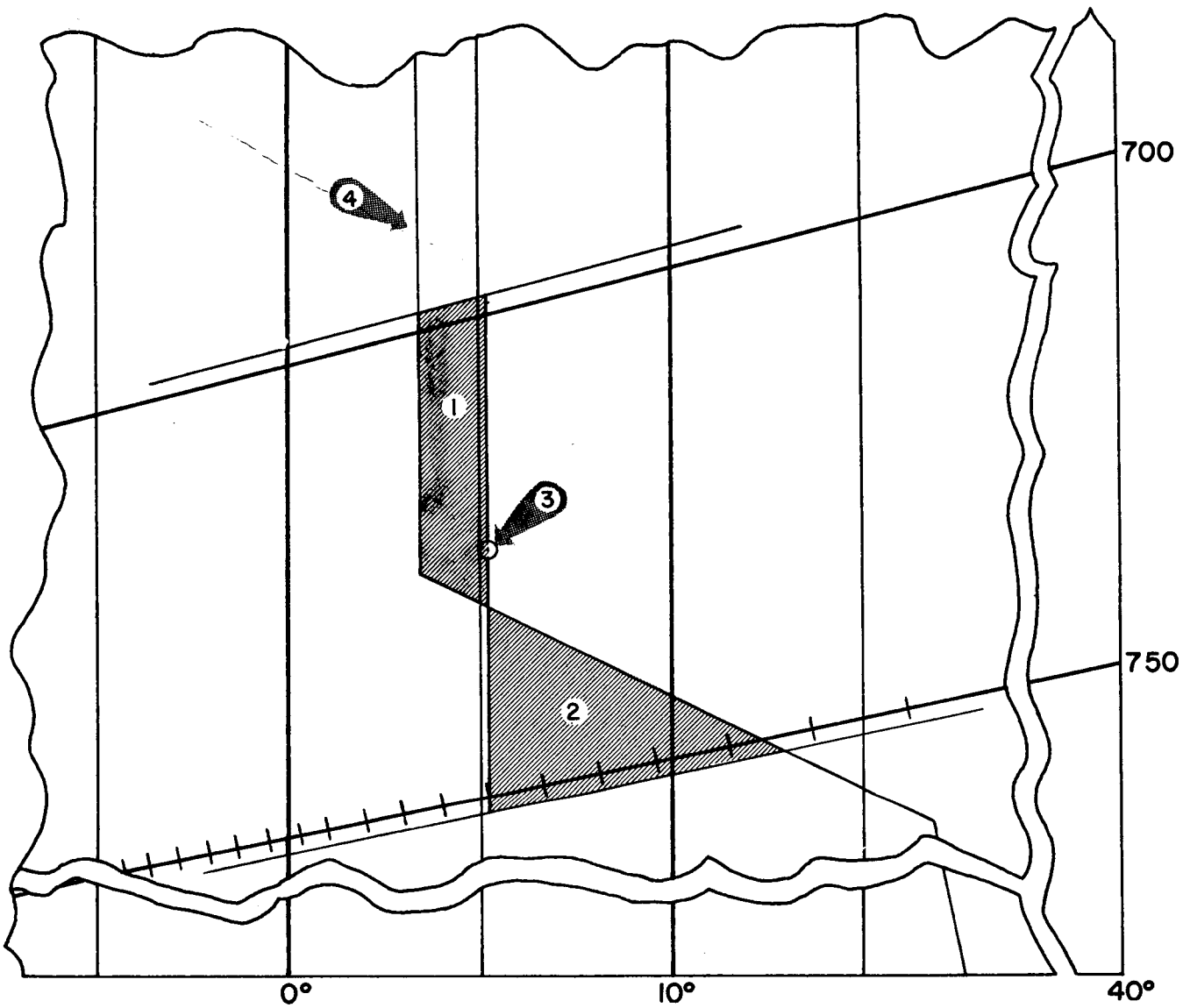

Figure 92. Balancing straight line sounding curve.

141. Evaluation of Temperature, Density, and Pressure on Chart ML-574

★*a. Evaluation of the First Leg of the Sounding Curve.* The evaluation of the sounding curve is begun at the surface level. Surface virtual temperature and surface pressure/density are read directly from the chart at the significant point

representing the surface. The surface significant point is inclosed in a square (fig. 89) on the isobar drawn through this point. The words, "surface pressure," "surface density," and "surface virtual temperature" are entered on the chart immediately below the surface isobar (fig. 89). The midpoint of each zone (previously iden-



①
Figure 93. Balancing irregular areas.

tified, circled, and numbered) is evaluated for temperature to the nearest 0.1° C. the midpoint of each computer zone is evaluated for pressure to the nearest millibar and the midpoint of each NATO zone is evaluated for density to the nearest whole gram per cubic meter. Pressure and density are evaluated by either an accurate visual interpolation between the constant pressure/density lines or an accurate measurement. Scale ML-573 may be oriented so that an even number (preferably 10 or 20) of graduations on the meter scale are between the pressure/density lines bracketing the zone midpoint. With the scale so oriented, the mean pressure/density of

the midpoint may be read to the nearest whole millibar/gram per cubic meter. Zone midpoint values are entered to the right and left of the midpoint, with the density above the temperature and the pressure below the computer zone number (fig. 89). The pressure at the top of each zone is evaluated to the nearest whole millibar and entered at the right end of the isobar drawn at the top of the zone and to the right of the sounding curve (fig. 89). Since chart ML-574 is used to obtain data for both the computer and NATO met messages, the following procedure will be followed for evaluation. The sounding curve plotted on the chart will be evaluated for

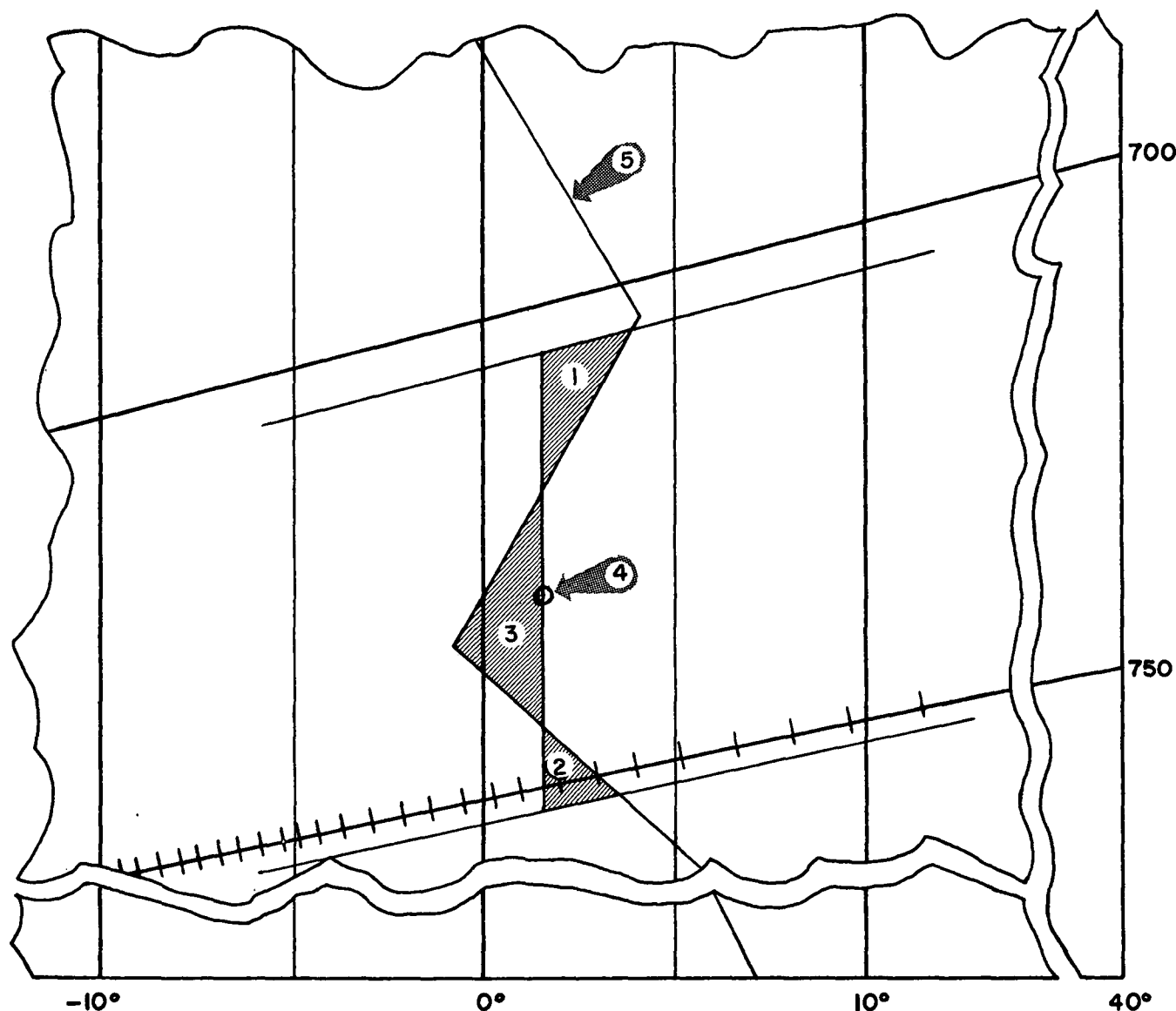

②
Figure 93—Continued.

the computer structure. Data to be used for the NATO message will be extracted from the chart for those zones where the computer and NATO structures are the same (1, 2, 3, 4, 5, and computer 12 (NATO 9)). For those zones where the computer and NATO structures differ, it will be necessary to determine the NATO zone midpoints data by averaging the midpoint data evaluated for the two computer zones that make up a NATO zone. This is illustrated in figure 89. Once the two computer zones that make up a NATO zone have been balanced and midpoints have been established, the temperature-density plotter will proceed as follows:

(1) Place a straight edge so that it touches the midpoint of each of the computer zones that make up a NATO zone.

(2) Draw a line connecting the two computer midpoints.

★(3) The point at which this line intersects the line (pressure line) previously drawn as the top of the previous computer zone is the midpoint of the NATO zone.

(4) Evaluate this point for density in grams per cubic meter and temperature to the nearest 0.1° C.

(5) The NATO zone midpoint will be identified by the zone number circled and placed to

the left of the sounding curve. The density and temperature evaluated at the midpoint will be placed to the right of the sounding curve.

★(6) The top of each fallout zone is identified by inclosing the zone number in a triangle at a point to the left of the sounding curve and above the isobar drawn at the top of the zone. The fallout zone pressure is entered at the right end of the isobar signifying the top of each fallout zone. In figure 89 the pressure for the top of zone 5 is 766 mb, and the pressure for the top of fallout zone 1 is 766 mb.

b. Evaluation of the Second Leg of the Sounding Curve. The second leg of the sounding curve is evaluated in exactly the same manner as the first leg, except that density and pressure values are read from the left edge of the chart.

c. Evaluation of the Third Leg of the Sounding Curve. The third leg of the sounding curve is evaluated in the same manner as the second leg except that the values of density and pressure read from the left edge of the chart are divided by 2.

d. Evaluation of the Fourth Leg of the Sounding Curve. The fourth leg of the sounding curve is plotted on the low-pressure side of chart ML-574 and is evaluated in the same manner as the first leg.

142. Development of Zone Temperatures and Pressures for the Computer Met Message

a. Temperature is reported on the computer met message to the nearest one-tenth of a degree Kelvin. These temperatures are obtained by algebraically adding 273.2° to all computer midpoint temperatures. This temperature is recorded in a four-digit group on the computer met message omitting the decimal point.

Example: 273.2°
+18.0° C. (midpoint temperature, zone 3, fig. 94)

291.2° K. = Recorded as 2912 on computer message

★*b.* The pressure reported on the computer met message is the midpoint pressure for each computer zone as determined on chart ML-574. Pressure is recorded to the nearest millibar on the computer met message in a four-digit group.

143. Computation of Ballistic Temperature

Ballistic temperatures are computed on DA Form 6-44 (Ballistic Density or Temperature) (fig. 94). The type of message being prepared is

checked in the lower left corner. Ballistic temperatures, reported as percents of standard, are obtained by applying weighting factors to the zone values.

a. Surface (Line 0) Ballistic Temperature. The surface ballistic temperature is obtained by reading the surface virtual temperature to the nearest 0.1° C. (31.5° C.) from chart ML-574 (fig. 89) and converting this temperature to the nearest 0.1 percent of standard by using chart XII, FM 6-16. After the appropriate words in the heading of column (1) are checked on the form, the surface virtual temperature is entered in column (1) and the percent of standard is entered in column (2).

b. Ballistic Temperatures for Lines 1 through 15. Ballistic temperatures for lines 1 through 15 are computed by weighting the individual zone temperatures. Each zone temperature is read to the nearest 0.1° C. from chart ML-574 and recorded in column (1) on the form (fig. 94). Next, the percent of standard for each zone temperature and the zone weighted temperature (percent) for each line are obtained from the appropriate weighted temperature table in FM 6-16. Zone 1 temperature (29.7° C.) is weighted first. Enter table IIIg, FM 6-16, weighted temperatures (percent), zone 1 (Type-3 Message (surface to surface)). The zone 1 temperature (29.7° C.) is used as the argument to enter the ° C. column. The percent of standard temperature (105.4) to the nearest 0.1 percent is read opposite the zone temperature, interpolating where necessary, and is recorded on the form in column (2) opposite the zone 1 temperature. The weighted temperature (percent) for each line of zone 1 is opposite the zone temperature in the table. These weighted temperatures (percents) are read to the nearest 0.1 percent, interpolating where necessary, and are recorded on the form under the appropriate line numbers for zone 1. The weighted temperature (percent) for a particular line of zone 1 represents the proportional part of the total temperature effect on the zone 1 temperature for that line. The weighted temperatures (percents) for zones 2 through 15 are obtained and recorded in the same manner as the zone 1 values. After the required weighted temperatures (percents) have been determined and recorded, the weighted values for each line are added algebraically (negative weighted values are encountered in the temperature weighting factors (type-3) (surface-to-surface trajectories) table IIIf, FM 6-16), and the sums are the ballistic values entered on the form. Each of these

BALLISTIC DENSITY OR TEMPERATURE

(FM 6-15)

STATION		LOCATION		RE-LEASE TIME		DATE		HOUR		FLIGHT NO.									
3d INF DIV ARTY		FT. SILL, OKLA		LST 17 FEB 64		17 FEB 64		1130		3									
(CHECK ONE)		(1)		(2)		(3)													
ZONE NUMBER	DENSITY Gm/M ³	TEMPERATURE (C°)	PERCENT OF STANDARD	1	2	3	4	5	6	7	8	9	10	11	12	13	14	15	
SUR 0	29.8		105.2																
1	28.0		104.8	104.8	28.3	13.6	8.4	5.2	4.2	2.1	1.0	1.0							
2	23.4		103.8	75.7	20.8	12.5	10.4	4.2	4.2	3.1	1.0								
3	16.7		102.3			68.5	25.6	20.5	9.2	7.2	5.1	2.1							
4	15.0		102.9				56.7	21.6	11.3	9.3	4.1	3.1							
5	12.2		103.1					45.4	13.4	11.4	10.3	3.1							
6	3.3		101.7						60.1	26.4	19.3	9.2							
7	0.4		103.1							42.3	23.7	13.4							
8	-5.1		103.6								36.3	24.9							
9	-11.4		103.7									45.7							
10																			
11																			
12																			
13																			
14																			
15																			
BALLISTIC VALUES				104.8	104.0	102.9	103.2	103.1	102.4	102.9	102.9	103.5							103.5
COMPUTER				GOODMAN															
MESSAGE TYPE (CHECK ONE)				STEPHENSON															
S			A																

REPLACES DA FORM 6-44, 1 JUL 56 AND DA FORM 6-45, 1 JUL 56, WHICH ARE OBSOLETE.

GPO : 1982 O-638173

★ Figure 94. Computed ballistic temperatures.

DA FORM 1 MAR 62 6-44

sums is a ballistic temperature in percent of ICAO standard atmosphere. These ballistic temperatures are encoded as a percent of standard on the NATO message.

144. Computation of Ballistic Density

Ballistic densities are computed on DA Form 6-44 (Ballistic Density or Temperature) (fig. 95). The NATO densities read from chart ML-574 are recorded on this form. Check the block marked DENSITY Gm/M³ to indicate that the form is being used to compute density and then enter the surface density on the appropriate line in column (1). The densities for the remaining zones are read from chart ML-574 and are entered in column (1) opposite the appropriate zone number. The type of message being prepared is checked in the lower left corner of the form.

a. *Surface (Line 0) Ballistic Density.* The surface ballistic density is determined by converting the surface density to the nearest 0.1 percent of standard surface density. The surface density (1105 Gm/M³) in column (1) of the form is used as the argument for entering chart IX, FM 6-16. The surface ballistic density to the nearest 0.1 percent (90.2) is obtained and is entered in column (2).

b. *Ballistic Densities for Line 1 through 15.* Ballistic densities for lines 1 through 15 are computed by weighting the density for each zone. Each zone density is read to the nearest whole gram per cubic meter from chart ML-574 and is entered in column (1) on DA Form 6-44. Next, the percent of standard of each zone density is obtained from the appropriate weighted densities table in FM 6-16. The example shown in figure 95 is a type-3 message (surface to surface);

BALLISTIC DENSITY OR TEMPERATURE (FM 6-15)																		
STATION			LOCATION			RE-LEASE TIME		DATE		HOUR		FLIGHT NO.						
3D INF DIV ARTY			FT SILL, OKLA					17 FEB 64		1130		3						
			GMT		17 FEB 64		1730											
ZONE NUMBER	(CHECK ONE)		PERCENT OF STANDARD (2)	WEIGHTED VALUES (3)														
	<input checked="" type="checkbox"/> DENSITY Gm/M ³	<input type="checkbox"/> TEMPERATURE (C°)		1	2	3	4	5	6	7	8	9	10	11	12	13	14	15
SUR 0	1105		90.2															
1	1100		90.7	90.7	39.0	19.9	13.6	10.0	7.3	5.4	4.5	3.6	2.7	0.9	1.8	1.8	1.8	
2	1087		91.8		52.4	28.4	19.2	15.6	10.1	7.4	5.5	5.5	3.7	2.8	2.8	1.8	2.8	
3	1060		93.0			43.7	29.8	23.3	15.8	13.0	10.2	8.4	6.5	4.7	4.7	3.7	4.7	
4	995		91.8				29.6	20.2	15.6	12.0	10.0	8.2	6.4	4.6	4.6	4.6	4.6	
5	946		91.7					22.9	13.8	11.0	9.2	7.4	6.4	5.5	4.6	4.6	4.6	
6	889		92.9						29.8	20.5	17.7	15.8	12.1	11.2	10.2	10.2	9.3	
7	800		92.7							22.2	15.8	13.9	11.1	10.2	9.3	8.3	8.3	
8	726		93.5								19.6	13.1	10.3	8.4	8.4	8.4	7.5	
9	657		94.2									16.9	10.4	8.5	7.6	7.6	6.6	
10	561		95.1										23.8	15.2	13.3	13.3	12.3	
11	450		96.4											22.2	11.6	9.6	10.6	
12	347		95.1												15.2	8.5	7.6	
13	267		100.2													12.0	6.0	
14	201		103.2														8.2	
15	146		102.6														6.1	
BALLISTIC VALUES			90.2	90.7	91.4	92.0	92.2	92.0	92.4	92.5	92.5	92.8	93.4	94.2	94.1	94.4	94.9	95.0
MESSAGE TYPE (CHECK ONE)			COMPUTER			CHECKER												
S <input checked="" type="checkbox"/> A			SCHEIRER			TAYLOR												

DA FORM 6-44
1 MAR 52

REPLACES DA FORM 6-44, 1 JUL 55 AND DA FORM 6-45, 1 JUL 55, WHICH ARE OBSOLETE.

GPO : 1962 O-65173

Figure 95. Computed ballistic densities.

therefore, table IIIb of FM 6-16 is used. The zone 1 density (1100) is used as the argument for entering the table. The weighted density for zone 1 is determined to the nearest 0.1 percent of standard (90.7). This value is entered in column 2 opposite the density for zone 1 (1100, fig. 95). After the zone percent of standard for each density has been determined and entered in column 2 on the form, the weighted zone densities for each line are obtained from the weighted densities table in FM 6-16 that corresponds to the message type. These weighted values are entered under the appropriate line numbers of the zone. For example, line-zone number 71 indicates that

the weighted value (5.4) is entered under the column for line 7 on the row for zone 1. The weighted density is that portion of the total density effect that the density in zone 1 exerts. The percents of standard and the weighted densities for zones 1 through 15 are obtained and entered on the form in the same manner. The percents of standard densities are used only for checking purposes. After the required weighted densities have been determined and recorded, the ballistic density values for each line are obtained by adding the weighted densities of each column (1 through 15). These sums are recorded in the ap-

appropriate space under the line number. These ballistic densities are now ready for encoding on the

met message form. (See chap 8 for the encoding procedure.)

Section VI. DUTIES OF BALLISTIC WINDS TEAM AFTER BALLOON RELEASE

145. General

The rawin set, used in conjunction with a balloon-borne radiosonde and the radiosonde recorder, provides a method of determining winds aloft during all kinds of weather. The determination of winds aloft involves tracking the radiosonde in elevation and azimuth and determining the height of the radiosonde by pressure-temperature measurements. The determination of zone wind directions and zone wind speeds from the rawin data requires both plotting and computations. The explanation which follows outlines the duties of the winds team and the method of determining zone winds, which will be known as the

average winds within a given zone. Normally, an artillery met section will be required to furnish both a computer and NATO met message for artillery. For the purpose of this manual, these messages will be prepared concurrently. The procedure outlined can be followed regardless of whether these messages are prepared concurrently or separately.

146. Duties of the Zone Wind Computer and Zone Wind Plotter

- a. During the flight, the zone wind computer—
 - (1) Marks each reference time on the con-

RAWIN COMPUTATION (FM 6-15)												
STATION				LOCATION				RE-LEASE TIME		DATE		FLIGHT NO.
3 RD INF DIV ARTY				FT. SILL, OKLA.				LST	17 FEB 64	1130	3	
		GMT		17 FEB 64		1730						
ZONE NUMBER	ZONE HEIGHT (meters)	PRESSURE AT TOP OF ZONE	TIME AT TOP OF ZONE	ELEVATION ANGLE (degrees & tenths)	AZIMUTH ANGLE (degrees & tenths)	HORIZONTAL DISTANCE (meters)	HORIZONTAL TRAVEL IN ZONE (meters)	TIME IN ZONE (minutes & tenths)	ZONE WIND DATA		BALLISTIC DATA	
									AZIMUTH (10 miles)	SPEED (knots)	AZIMUTH (100 miles)	SPEED (knots)
OFFSET	SUR								SUR	SUR	SUR	SUR
					12.6	100			310	004		
1	200	946	0.6	33.2	335.2	310	240	0.6	249	013		
2	500	913	1.6	37.0	347.5	660	370	1.0	316	012		
3	1000	861	3.5	38.3	05.6	1270	680	1.9	361	012		
4	1500	812	5.2	39.4	12.8	1820	590	1.7	371	011		
⑤ 5	2000	766	6.8	47.0	24.6	1860	380	1.6	503	008		
6	2500	720	8.3	46.4	37.8	2380	700	1.5	455	015		
⑥ 7	3000	678	9.9	46.1	48.0	2880	690	1.6	473	014		
8	3500	638	11.6	47.1	59.4	3250	710	1.7	520	014		
⑦ 9	4000	599	13.3	49.4	75.1	3420	930	1.7	581	018		
10	4500	562	15.0	49.2	88.8	3880	970	1.7	578	018		
⑧ 11	5000	527	16.8	48.1	97.4	4480	870	1.8	567	016		
⑨ 12	6000	462	20.2	46.2	108.4	5750	1590	3.4	572	015		
13	7000	404	23.3	47.4	113.8	6430	890	3.1	587	008		
⑩ 14	8000	352	26.7	48.1	120.4	7160	1070	3.4	611	010		
15	9000	306	30.0	51.9	110.6	7040	1210	3.3	355	012		
⑪ 16	10000	264	33.1	52.5	100.8	7660	1410	3.1	396	015		

MESSAGE TYPE (CHECK ONE) (13)			ZONE WIND COMPUTER		ZONE WIND PLOTTER		BALLISTIC WIND PLOTTER	
BALLISTIC	FALLOUT	COMPUTER	STEPHENSON		KELSEY		GOODMAN	
S	A	✓						

DA FORM 6-46
1 MAR 62

PREVIOUS EDITION OF THIS FORM IS OBSOLETE.

Figure 96. DA Form 6-46 (Rawin computation).

RAWIN COMPUTATION (FM 6-15)										
ZONE NUMBER	ZONE HEIGHT (meters) (1)	PRESSURE AT TOP OF ZONE (2)	TIME AT TOP OF ZONE (minutes & tenths) (3)	ELEVATION ANGLE (degrees & tenths) (4)	AZIMUTH ANGLE (degrees & tenths) (5)	HORIZONTAL DISTANCE (meters) (6)	HORIZONTAL TRAVEL IN ZONE (meters) (7)	TIME IN ZONE (minutes & tenths) (8)	ZONE WIND DATA	
									AZIMUTH (10 mfa) (9)	SPEED (knots) (10)
11 ¹⁶ △	10000	264	33.1	52.5	100.8	7660	1410	3.1	396	015
17	11000	228	36.2	52.7	91.8	8360	1450	3.1	383	015
12 ¹⁸ △	12000	196	39.6	50.0	78.1	10040	2760	3.4	379	026
19	13000	168	42.8	47.8	72.2	11750	2000	3.2	393	020
13 ²⁰ △	14000	143	45.6	46.8	71.6	13100	1420	2.8	438	016
21	15000	122	48.4	49.2	78.2	12910	1510	2.8	625	017
14 ²² △	16000	104	51.5	51.6	86.3	12640	1810	3.1	002	019
23	17000	88	55.0	52.8	97.1	12860	2400	3.5	632	022
15 ²⁴ △	18000	76	57.6	57.0	107.2	11650	2480	2.6	075	031
25	19000	64	61.1	61.5	116.7	10280	2280	3.5	104	026
26 ²⁶ △	20000	55	63.9	68.0	125.9	8050	2660	2.8	156	031
MESSAGE TYPE (CHECK ONE) (13)				ZONE WIND COMPUTER				ZONE WIND PLOTTER		
BALLISTIC		FALLOUT								
S	A	COMPUTER ✓								

U.S. GOVERNMENT PRINTING OFFICE : 1962 O-639198

Figure 96—Continued.

trol-recorder tape with the contact number it represents.

(2) Constructs a pressure-time plot on the pressure-time chart.

(3) Records in column (2) on DA Form 6-46 (Rawin Computation) (fig 96), the pressure evaluated at the top of each zone on chart ML-574 by the temperature-density plotter.

(4) Reads from the pressure-time chart the time of arrival of the balloon-borne radiosonde at each standard height (pressure) and enters these times in column (3) on the form.

(5) Determines from the control-recorder tape the values of the elevation and azimuth angles at the time the radiosonde reached each standard height. Applies to the angular data the corrections obtained by the optical-electrical bearing check. Enters the corrected angular data in columns (4) and (5) on the form.

(6) Determines from table Ig, FM 6-16 the values of horizontal distance corresponding to the elevation angle for each standard height and enters these values in columns (6) of the form.

(7) Enters the surface wind values and appropriate heights on the form.

(8) Assists and checks the work of the ballistic wind plotter.

b. During the flight, the zone wind plotter—

(1) Plots the zone winds.

(2) Determines the wind direction and the distance traveled by the radiosonde in each zone.

(3) Computes the wind speed in each zone.

(4) Assists and checks the work of the zone wind computer.

147. Preparation of Zone Wind Data

a. *Pressure-Time Curve.* DA Form 6-49 (Pressure-Time Chart) (fig 97), is a semilog graph used to plot the pressure-time curve. This curve is used to determine the times at which the radiosonde reached standard heights. The vertical axis is a log scale of pressure in millibars, and the horizontal axis is a linear scale of time in minutes. The front of DA Form 6-49 (fig 97) is divided into two segments and is used to plot the pressure-time curve from the surface to 100 mb. The back of DA Form 6-49 (fig 97—cont) is used for plotting the upper segments of the pressure-time curve and extends to 1 mb. Each side of the chart has a block for recording the data used to plot the pressure-time curve. Column (1) of the block lists reference contact numbers. Column (2) provides a space for recording the pressures which correspond to the reference contact numbers. These pressures are obtained from the pressure calibration chart. Column (3) provides a space for recording the time corresponding to each reference contact number. These times are

read directly from the control-recorder tape, where they are identified by asterisks. The pressure in column (2) and their corresponding times in column (3) are used to plot a pressure-time curve.

Figure 97. DA Form 6-49 (Pressure-Time Chart).
(Located in back of manual)

Figure 97—Continued.
(Located in back of manual)

b. Plotting the First Leg of the Pressure-Time Curve. As each reference time is printed by the control-recorder, it is entered in column (3) on DA Form 6-49. Each reference time and the corresponding pressure in column (2) are used to plot a point on the pressure-time chart. The surface pressure is plotted at zero time. The plotted points are circled and connected with straight lines to construct the pressure-time curve. The first segment of the pressure-time chart is used to plot the first leg of the pressure-time curve. This is that portion of the curve with pressures up to 400 mb.

c. Plotting the Second and Subsequent Legs of the Pressure-Time Curve.

(1) The second segment of the pressure-time chart extends from 450 to 100 mb. The overlap in pressure with the first segment facilitates the transfer of the first leg of the curve to the second segment of the chart, on which the second leg of the curve is plotted. The times are not printed on the second and subsequent segments of the chart and must be written in by the plotter. This procedure allows flexibility in plotting the second and subsequent legs of the curve because of the varying times at which different flights reach the 400 mb level (i.e., the top of the first leg). For example, the first leg of the pressure-time curve illustrated in figure 97 ended at a pressure of 413 mb and a time of 22.8 minutes. The times on the second segment were then written in, beginning with 22 minutes and ending with 63 minutes. The second segment of the pressure-time curve was plotted in the same manner as the first segment of the graph.

(2) The low-pressure side of the pressure-time chart extends from 125 to 10 mb on the left scale and from 12.5 to 1 mb on the right scale. This side of the chart is used to plot the final leg(s) of the pressure-time curve. The pressure and time values at the top of the second leg of the curve are transferred to the low-pressure side of the chart in the same manner as they were transferred from the first to the second leg. Appropriate times must be entered on the

horizontal scale of the low pressure side of the chart by the plotter (fig 97). The low-pressure side of the chart contains a block for recording the pressures and times of the reference contact numbers to be used in plotting the upper portion of the pressure-time curve. These values are determined in the same manner as those used on the front. After the third leg of the curve is plotted, a fourth leg, if necessary, may be plotted by using the pressure scale on the right edge of the graph.

(3) The completed pressure-time curve is used to determine the times at which the standard heights were reached by the radiosonde. These times are determined by the point of intersection of the pressure-time curve and the isobars whose values are the same as the pressure at each standard height. The pressure at each standard height is read from the altitude-pressure-density chart ML-574.

d. Determining Time at Standard Height. The zone wind plotter obtains the pressure at the top of each zone from chart ML-574 and enters these pressures in column (2) on the rawin computation form (fig 96). The pressure at the top of each zone is used as the argument for entering the pressure-time chart. The zone wind plotter moves horizontally along an isobar equal to the pressure at the top of each zone until the isobar intersects the pressure-time curve, then reads the time on the time scale (at the top or bottom of the chart, as applicable). The values of time are read directly from the scale to the nearest 0.1 minutes. For example, the pressure corresponding to the top of computer zone 11 (standard height) is 527 mb and the time is 16.8 minutes. This time is entered in column (3) opposite zone number 11 on DA Form 6-46 (fig 96).

e. Correcting for Erroneous Release Contact. When the actual release contact number differs from the correct surface contact number by 0.2, 0.3, and 0.4 contact, a contact correction must be applied to each contact evaluated on the recorder record. This correction must also be applied to each reference contact number shown on DA Form 6-49 (fig 97). If, for example, the contact number corresponding to a surface pressure of 967 mb is 5.3 and the actual release contact number is 4.9, the subsequent contact numbers must be corrected to obtain correct pressure values from the pressure calibration chart. In this example, the contact numbers on the recorder record are corrected for use with the pressure calibration chart by adding a contact correction of

+0.4 contact. When a reference trace is printed on the recorder record, a time print (marked with an asterisk) is printed automatically on the control-recorder tape (fig 98) and represents the time the radiosonde reached the pressure at the beginning of the reference trace. Thus, if the contact numbers differ, the time printed on the control-recorder tape represents the time the radiosonde reached the pressure corresponding to the correct contact number at the beginning of the reference trace. Since the preflight plot on the pressure-time chart is prepared with the uncorrected reference contact numbers, the preflight phase must be corrected when a contact error exists. The procedure is to cross out the uncorrected reference contact numbers printed on the chart and enter the corrected contact numbers. Then the pressures corresponding to the corrected contact numbers are read from the pressure calibration chart and recorded. The corrected reference contact pressures are used to plot the pressure-time curve.

f. Determining Angular Data. Construction of the zone wind plot requires the elevation and azimuth angles to the radiosonde at zone limits. The elevation and azimuth angles corresponding to the times at standard heights (*d* above) are obtained from the control-recorder tape, rounded off to the nearest 0.1 degree, and entered in columns (4) and (5), respectively, on DA Form 6-46. For example, the elevation angle corresponding to the time of 16.8 minutes (at standard height of computer zone 11) on the control-recorder tape in figure 98 is 48.1° and the azimuth angle is 97.4 degrees (elevation angles are printed to the left of the time print). These data are entered opposite zone 11 in columns (4) and (5) on DA Form 6-46 (fig 96). If corrections are applied to the angular data for nonalignment of the optical and electrical axes of the rawin set, the printed values of the angles are crossed out, and the corrected values are entered adjacent to the crossed-out values on the control-recorder tape. The determination of angular corrections is described in paragraph 79c.

g. Determination of Horizontal Distance. Zone winds are computed from a projection of the radiosonde flight path on a curved earth. Thus, it is necessary to know the distance from the rawin set to the point on the ground directly under the balloon. Table Ig, FM 6-16, provides the horizontal distance traveled by the radiosonde for each standard height and is entered with the elevation angle to the radiosonde as an argument. The table is entered with the elevation angle to the

nearest 0.1°. The horizontal distance is read to the nearest 10 meters, and recorded in column (6) on DA Form 6-46 (fig 96). For example, the distance corresponding to the elevation angle of 48.1 degrees for computer zone 11 is 4,480 meters. The distances in table Ig are the arc distances or the distances projected to the earth's curved surface.

h. The Zone Wind Plot. The zone wind plot is made by plotting each horizontal distance (column 6) at the indicated azimuth (column 5) obtained from DA Form 6-46. The plot is made on plotting board ML-122 with rule ML-126 (fig 22). The center of the plotting board represents the location of the rawin set and the horizontal distances are plotted from the center. Rule ML-126 permits plotting at a scale of 1 inch equals 750 meters. The longer scale is graduated every 50 meters and marked in hundreds of meters at 500-meter intervals up to 17,000 meters. The shorter scale on this rule which is similar to the longer scale in numbering and graduations, is graduated up to 11,000 meters. At times it is necessary to expand or reduce the distance to be plotted. Multiplication factors of 2, 5, or 10, are used to magnify the distance to be plotted. To facilitate plotting it is necessary to expand the scale to a measurement of at least 500 meters when the distance to be plotted is less than 500 meters. For example, if the distance is between 250 and 500 meters, a minimum factor of 2 is required so that the product is 500 or greater; if the distance is between 100 and 250 meters, a minimum factor of 5 is required; and if the distance is less than 100 meters, a minimum factor of 10 is required. Normally the largest of the factors 2, 5, or 10 that will permit plotting of at least two consecutive points is the best choice for expansion of the scale. When the distance to be plotted is 500 meters or more, expansion is unnecessary. During the course of plotting, a point to be plotted may fall off the board. When this occurs, it will be necessary to reduce the plotting scale so that the point and subsequent points will fall on the plotting board. When reducing the scale, the same factors of 2, 5, or 10 may be used (preferably the smallest factor possible). To measure actual distance, the plotted distance must be divided or multiplied by the same factor used in plotting.

i. Plotting the Offset Release Point. If the release point is more than 50 meters from the rawin set, a plot of the release point must be made on the wind plotting board ML-122. This point is known as the offset release point. The

34	50	0 2.2	355	25	46	70	18.5	101	70
34	75	0 2.1	353	85	46	85	18.4	101	45
35	30	0 2.0	351	10	46	30	18.3	101	10
36	20	0 1.9	350	45	46	85	18.2	100	80
36	40	0 1.8	348	20			18.2 #45		
37	20	0 1.7	346	65	47	30	18.1	100	65
37	05	0 1.6	347	50	47	15	18.0	100	45
		0 1.6 * 10			47	15	17.9	100	20
38	25	0 1.5	344	75	47	15	17.8	99	30
38	05	0 1.4	344	10	47	20	17.7	99	70
39	05	0 1.3	342	30	47	25	17.6	99	55
39	95	0 1.2	339	70	47	40	17.5	99	15
38	75	0 1.1	339	40	47	55	17.4	99	05
38	55	0 1.0	337	95	47	70	17.3	98	90
37	40	0 0.9	335	80	47	30	17.2	98	50
37	55	0 0.8	334	50	47	85	17.1	98	20
35	05	0 0.7	338	25	47	85	17.0	97	80
33	15	0 0.6	335	20	47	65	16.9	97	60
29	30	0 0.5	336	75	48	15	16.8	97	40
26	75	0 0.4	339	45	48	20	16.7	97	15
22	55	0 0.3	339	80	48	25	16.6	96	95
18	25	0 0.2	340	95	48	40	16.5	96	10
10	45	0 0.1	354	85	48	70	16.4	95	85
00	30	0 0.0	12	50	48	50	16.3	95	30

Figure 98. Control-recorder tape.

distance and the azimuth from the rawin set to the release point are used to plot the offset release point. The distance may be determined by

spacing. The azimuth used is the first azimuth angle printed on the control-recorder tape. The plot of the offset release point is used as the ori-

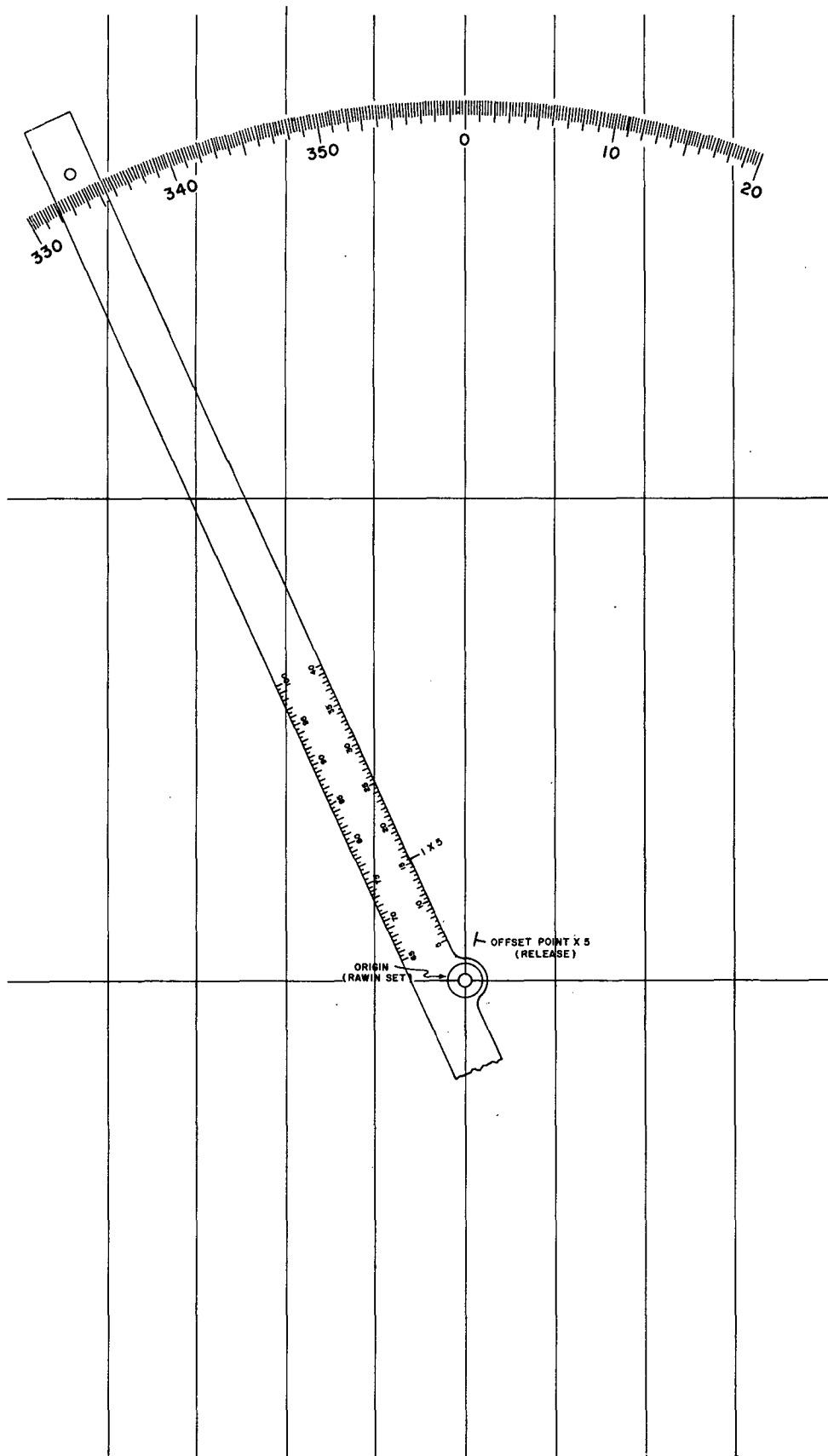

Figure 99. Plotting zone winds.

gin for determining the travel and direction for zone 1 winds.

j. Plotting Zone Winds. Plotting begins as soon as the horizontal distance traveled in zone 1 has been determined. Plotting board ML-122 is oriented by placing north directly away from the plotter. Then the pivot hole of plotting rule ML-126 is placed on the pin in the center of the azimuth circle on the plotting board (fig. 99). The pin can be raised by pushing forward on the lever beneath the board. The rule is then placed so that the edge in line with the pivot hole passes over the appropriate azimuth on the plotting board. Opposite the appropriate distance on the edge of the rule, the radiosonde position is marked with a small T-shaped index formed by a straight line (the top of the T) along the edge of the rule and a short tick mark (the stem of the T) perpendicular to the line. Each point plotted is identified by the zone number(s) at which the angular data was read. If the plot is made at other than the normal scale, the factor by which the distance is expanded or reduced is shown after the zone number by writing a multiplication or division sign and the factor used (1×5) (fig. 99). In this manner the angular data for each of the required standard heights are plotted. A complete zone wind plot for the radiosonde sounding is shown in figure 100.

Figure 100. Completed zone wind plots.
(Located in back of manual)

★*k. Measuring Travel in Zone.* Travel in zone is the net distance in meters in a given zone that the balloon-borne radiosonde moves in the horizontal direction. When the amount of time in zone is known, the zone wind speed is obtained by dividing the distance traveled by the time in zone and converting the result to knots. The distance traveled in each zone is measured in meters with rule ML-126. This is done by aligning the rule between the two plotted points representing the bottom and top of the zone in which the horizontal movement is to be measured. The distance traveled between the two points is read on the rule to the nearest 10 meters. With the rule still in alinement, draw a fine line along the edge of the rule between the plotted points and extend it, if necessary, to make a line at least 5 inches long. This line is the zone wind direction line. The travel is measured for each zone required. If the scale of the zone wind plot is ex-

Figure 101. Measuring zone wind direction.
(Located in back of manual)

panded or reduced by a given factor, the value of distance traveled as read on the rule must be multiplied or divided by the same factor. The values of distances traveled in zone are entered in column (7) on the DA Form 6-46 (fig. 96). For example, the distance traveled in zone 7 is recorded on the form as 690 meters.

Caution: Zone wind data (direction and travel) must be measured between like plots; i.e., both plotted at normal value, both plotted at expanded value of the same factor, or both plotted at reduced value of the same factor.

★*l. Measuring Zone Wind Direction.* The zone wind direction is measured for each zone by using scale ML-577. The center reference mark of scale ML-577 is placed over the zone lower limit plot, and the scale is oriented so that the north-south reference line is parallel to the north-south reference lines on the plotting board and the arrow is pointed toward the top of the board. The zone wind direction is read to the nearest 10 mils at the point where the zone wind direction line and the side of the scale intersect (fig. 101 and 119).

m. Computing Time in Zone. Column (3) of the rawin computation form lists the time of arrival of the radiosonde at each standard height. Time in zone 1 begins at surface (zero time) and ends at standard height 1. The time in zone 2 is equal to the time at standard height 2 minus the time at standard height 1. The time in zone for each succeeding zone is determined in a similar manner. These values are entered in column (8) of DA Form 6-46.

n. Computing Zone Wind Speed.

(1) *Zone wind speed.* Each zone wind speed is computed by the formula, $D/T \times 0.0324 = S$, where D is the horizontal travel in meters, T is the time in zone in minutes and tenths, and S is the zone wind speed in knots. The factor 0.0324 is used to convert meters per minute to knots. Each zone wind speed in knots is entered in column (10) on DA Form 6-46. The computations are performed with a slide rule as follows:

(a) The hairline on the indicator is set over the horizontal travel on the D scale.

(b) The time in zone on the C scale is moved under the hairline.

(c) The hairline is moved to 0.0324 on the C scale. If the value 0.0324 on the C scale is on the portion of the slide which extends from the body of the slide rule, the hairline is set over the index on the C scale. Then the other index on the C scale is moved under the hairline, and the hairline is set on the value of 0.0324 on the C scale.

(d) The zone wind speed is read under the hairline on the D scale.

★(2) *Approximation of zone wind speed.* When the slide rule is used to calculate the zone wind speed (as described in (1) above), the position of the decimal point must be determined. For example, a slide rule reading of 2779 may be a wind speed (to the nearest knot) of 3 (2.8), 28 (27.8) or 278 (277.9). In order to place the decimal point in the number read from the slide rule, a mental calculation may be made of the approximate wind speed. In making this calculation, 30 meters per minute is used as the approximate equivalent of 1 knot. For example, the approximation may be made as follows:

2770 meters = horizontal travel in zone
 2800 meters = approximate horizontal travel in zone
 3.4 minutes = time in zone
 3.0 minutes = approximate time in zone
 30 meters = approximate meters per minute for 1 knot

Then $\frac{2800}{3.0} = 933$ meters per minute
 $\frac{933}{30} = 31$ knots, the approximate wind speed

Since the approximate wind speed has been calculated as 31 knots, it becomes obvious that the decimal point is placed between the second and third digits in the number, of 2779, read from the slide rule. Hence, the answer is 27.79 which is rounded off to 28 knots.

o. Surface Wind. The surface wind speed and direction are measured with an anemometer at the time of release. These data are entered in columns (11) and (12), respectively, on DA Form 6-46.

148. Determination of Zone Winds for the Computer and NATO Met Messages Prepared Concurrently

a. General. The computer structure will be plotted on plotting board ML-122 when messages are prepared concurrently. The zone wind directions and speeds for computer messages will be determined from the resulting plots. Data to be used to determine the NATO zone winds will be extracted from these plots.

b. Zone Winds for the Computer Met Message. Computer zone wind directions and speeds will be determined as outlined and explained in paragraphs 146 and 147. Wind directions to the nearest 10 mils are recorded on (in a three-digit group) DA Form 6-46 marked for COMPUTER (fig. 96). Wind speeds are recorded to the nearest knot in a three-digit group.

c. Zone winds for the NATO Met Message.

Zone wind directions and speeds for the NATO met message for those zones where the computer and NATO structures are the same (1, 2, 3, 4, 5, and computer 12 (NATO 9)) are extracted from DA Form 6-46 marked for COMPUTER (fig. 96) and recorded on DA Form 6-46 marked for BALLISTIC (fig. 102). For those zones where the computer and NATO structures differ, the zone wind directions and speeds must be computed using wind plots on plotting board ML-122 (fig. 100) as explained in (1) and (2) below.

★(1) *Zone wind directions.* Zone wind directions will be measured by scale ML-577/UM. It should be noted, in the structures for the computer and NATO messages that the thickness of all NATO zones are exactly twice that of the computer zones except for computer zones 1, 2, 3, 4, 5, and 12. Therefore zone wind directions for NATO zones that are not the same as computer zones are determined by positioning scale ML-577/UM for the measurement as illustrated in figure 101. The center of the scale is placed over zone plot 5. The scale is oriented and the wind direction to plot 7 (NATO zone 6) is read to the nearest 10 mils. This procedure is followed (moving the scale each time to the plot just measured) to obtain the wind direction for NATO zones 7 and 8. Since computer zone 12 is of the same thickness as NATO zone 9, the wind direction is obtained by measuring from zone plot 11 (NATO 8) to zone plot 12 (NATO 9). For the remaining NATO zones the procedure explained above will be followed; for example: center the scale over computer zone plot 12 (NATO zone 9) and read the direction to zone plot 14 (NATO 10) etc. Wind directions will be encoded on DA Form 6-46 (marked for ballistic) in column (9) to the nearest 10 mils (fig. 102).

★(2) *Zone wind speeds.* Zone wind speeds will be determined for the NATO zones that are not the same as the computer zones in the following manner:

★(a) The horizontal distance between the NATO zones is measured in meters with rule ML-126 (fig. 103). These distances are recorded on DA Form 6-46 and marked for BALLISTIC in column (7) (fig. 102).

(b) The time in zone for each NATO zone is computed by adding the time in zone of the two computer zones that make up a NATO zone and recording the time in column (8) of DA Form 6-46 (fig. 102).

(c) Zone wind speeds are computed as explained in paragraph 147.

RAWIN COMPUTATION (FM 6-15)															
STATION				LOCATION				RE-LEASE TIME		DATE		HOUR	FLIGHT NO.		
30 INF DIVARTY				FT. SILL, OKLA				LST 17 FEB 64		1130		3	3		
ZONE NUMBER		ZONE HEIGHT (meters)	PRESSURE AT TOP OF ZONE	TIME AT TOP OF ZONE	ELEVATION ANGLE (degrees & tenths)	AZIMUTH ANGLE (degrees & tenths)	HORIZONTAL DISTANCE (meters)	HORIZONTAL TRAVEL IN ZONE (meters)	TIME IN ZONE (minutes & tenths)	ZONE WIND DATA		BALLISTIC DATA			
		(1)	(2)	(3)	(4)	(5)	(6)	(7)	(8)	AZIMUTH (10 mile)	SPEED (knots)	AZIMUTH (100 mile)	SPEED (knots)		
OFFSET		SUR								SUR	SUR	SUR	SUR		
1										310	004	31	04		
2										249	013	25	13		
3										316	012	30	12		
4										361	012	34	12		
5				6.8						371	011	35	11		
6		3000		9.9				1390	3.1	503	008	41	08		
7		4000		13.3				1570	3.4	464	015	44	12		
8		5000		16.8				1840	3.5	555	015	51	10		
9		6000		20.2				1590	3.4	573	017	54	11		
10		8000		26.7				1940	6.5	572	015	54	13		
11		10000		33.1				2580	6.4	601	010	57	09		
12		12000		39.6				4170	6.5	377	013	49	07		
13		14000		45.6				3340	6.0	379	021	44	09		
14		16000		51.5				3320	5.9	411	018	44	10		
15		18000		57.6				4480	6.1	635	018	50	08		
16										035	024	53	07		
MESSAGE TYPE (CHECK ONE) (13)				ZONE WIND COMPUTER				ZONE WIND PLOTTER				BALLISTIC WIND PLOTTER			
BALLISTIC		FALLOUT		DUSSEAU				GOODMAN				THOMAS			
S ✓		A													
		COMPUTER													

DA FORM 6-46
1 MAR 62

PREVIOUS EDITION OF THIS FORM IS OBSOLETE.

Figure 102. DA Form 6-46 for NATO message.

(d) Zone wind speeds are recorded in column (10) of DA Form 6-46 (fig 102).

Figure 103. Measuring horizontal travel in zone.
(Located in back of manual)

149. Special Considerations

Ballistic meteorologists must have a general knowledge of meteorological conditions in order to interpret and evaluate an upper air sounding. When special weather phenomena are identified during a sounding, they should be considered valid meteorological data as long as the ballistic meteorologist knows that his equipment is in proper working order. If the computations are correct, the weather measurements are also correct. Icing and floating of the sounding balloon during ascensions are discussed in paragraphs 135c and d.

a. *Frontal Wind.* Wind is simply air in motion and is the result of differences in atmospheric

pressure between geographic locations. The flow of air is from high- to low-pressure areas, with a clockwise flow about the highs and a counterclockwise flow about the lows in the Northern Hemisphere. Pressure centers may be caused by differential heating; therefore, wind is a by-product of the changes in temperature and pressure. Both the speed and direction of the wind can change rather abruptly with a frontal passage. The location of pressure systems on a weather map are important in the final evaluation of the validity of ballistic winds.

b. *Wind Shear.* A wind shear is an abrupt change in either wind speed or direction within a small change in altitude. For example, the wind at an altitude of 500 meters is blowing from a direction of 3,200 mils at 14 knots; at an altitude of 625 meters, the wind is blowing from a direction of 5,500 mils at 37 knots. This wind phenomenon is not uncommon during soundings through

fronts and should be recognized by met personnel.

c. Jet Stream. A jet stream is a narrow belt of high velocity wind that occurs at upper levels in the troposphere. These meandering streams of wind normally occur at or near the tropopause height (para 8a). The tropopause is usually broken near the jet stream and reforms at a lower level, causing a folded, or "leaf-like pattern."

d. Local Storms. Thunderstorms are associated meteorological conditions which are extremely variable in both space and time. Therefore, any sounding made through a thunderstorm will not likely be representative of the meteorological conditions along the trajectory of an artillery projectile. For this reason, an effort should be made to adjust the schedule of release times when it is evident that the radiosonde will be influenced by a local thunderstorm.

150. Duties of the Ballistic Wind Plotter

During the flight, the general duties of the ballistic wind plotter are to—

- a. Plot the ballistic winds.
- b. Measure the ballistic wind speeds and directions.
- c. Record ballistic wind quantities on the rawin computation form.
- d. Check the work of the zone wind plotter.

151. Determining Ballistic Winds for a NATO Met Message

a. Ballistic Winds for Line 0 and 1. Line 0 (SUR) and line 1 ballistic winds are the same as the surface wind and zone 1 wind. Therefore, the zone wind data recorded in columns (9) and (10) for lines 0 and 1 are entered for the ballistic wind data in columns (11) and (12) on DA Form 6-46.

b. Plotting Lines 2 through 15.

(1) *General.* A projectile with a trajectory that has a maximum ordinate in excess of 500 meters (second standard height) is affected by winds in both zones 1 and 2. A projectile that rises to 1,000 meters (third standard height) is affected by winds in zones 1, 2, and 3; and a projectile that rises to 3,000 meters (sixth standard height) is affected by winds in zones 1, 2, 3, 4, 5, and 6. In general, the value of a ballistic wind for any given line of the met message is determined by considering the zone winds of all zones from the surface to the standard height of that line. The ballistic wind for any line above line 1 is obtained by making a plot of the weighted wind ef-

fect of each zone which contributes to the ballistic value of that line of the message. These plots take the form of vectors. The vector direction represents zone wind direction, and the magnitude of the vector represents the weighted zone wind speed. The sum of the zone wind vectors is the ballistic wind.

(2) *Selecting starting points.* The plotting board ML-122 is oriented so that the closely spaced parallel lines run from the top to the bottom of the board. The top of the board represents north. Origin points for the lines to be plotted are selected at the intersections of the horizontal and vertical lines. The proper selection of these origin points will depend on the direction and speed of the winds aloft and should afford maximum plotting space. The first origin selected is that for line 2. It usually is selected on the horizontal line that affords maximum plotting space in the direction that the plot is expected to extend. Its position along the line depends on the direction of the wind. If the wind is from the west, the origin is selected at one of the intersections near the left edge of the board. If the wind is from the east, the origin is moved farther to the right so that subsequent plots will not fall off the board. The remaining origins are placed along the same line as the first until they fall too close to the edge of the board; then another line is used. Each origin is numbered to represent the line being plotted. Therefore, it is possible to have origins numbering from 2 to 15.

(3) *Plotting zone 1 direction.* The center of scale ML-577 is centered over the origins for lines 2 through 15 and oriented so that the north-south lines of the scale are aligned with the north-south lines on the board. Since the projectile must pass through zone 1 in order to reach the higher zones, the wind direction for zone 1 is first plotted at each of the origins. The direction for zone 1 is plotted by selecting the azimuth along the outer edge of the scale which corresponds to the wind direction for zone 1 (2,490 mils in fig 104). The point of intersection is identified by a small T-shaped index formed by drawing a straight line (the top of the T) along the edge of the scale and a short tick mark (the stem of the T) perpendicular to the line (fig 104).

(4) *Determining zone 1 weighted wind speed.* The weighted wind speed tables in FM 6-16 are used to determine the weighted wind speeds. The table selected depends on the type of message. In figure 102, type 3 message(s) is checked. This means that the weighted wind speed table for a type-3 message (table IIIe) is

used. The arguments for entering the table are the line-zone number and the zone wind speed. The numbers across the top of the table are the line-zone numbers. In table IIIe, Weighted Wind Speeds (Type-3 Message), Zone 1, the first line-zone number is 21. This is interpreted as meaning line 2, zone 1 (i.e., the effect of zone 1 on line 2). The next line-zone number is 31 (line 3, zone 1). The wind speed to the nearest knot for zone 1 is used to enter the table. In figure 102, the zone 1 wind speed is 13 knots. By entering the table and interpolating for 13 knots the weighted wind speed for line 2, zone 1, is found to be 2.6 knots; for line 3, zone 1, the weighted wind speed is 1.2 knots; and for line 4, zone 1, the weighted wind speed is 0.8 knot.

(5) *Plotting zone 1 weighted wind speed.* In order to plot the first weighted value, the ballistic wind velocity scale on scale ML-577 is oriented so that the zero falls at the origin of the plot and

the edge indicating wind speeds extends through the point of intersection of the stem and top of the T-shaped index, or azimuth mark (fig 105). The weighted wind speed is plotted to the nearest 0.1 knot by interpolating between the printed graduations when necessary. The weighted wind speed determined from the table for zone 1 for line-zone 21 is 2.6-knots. With the zero end of the scale at the origin point for line 2 and the scale oriented through the azimuth mark, a straight line is drawn from the origin to the 2.6 knot graduation on the scale where a small tick mark is made perpendicular to the scale. For identification the plot is numbered 21. In order to indicate that this particular segment of the plot has been completed, a small "x" is drawn through the azimuth mark at the time the weighted speed is plotted. The scale is shifted to the next origin, which is 3. The same procedure is used to plot the weighted wind speed of 1.2 knots for line zone 31.

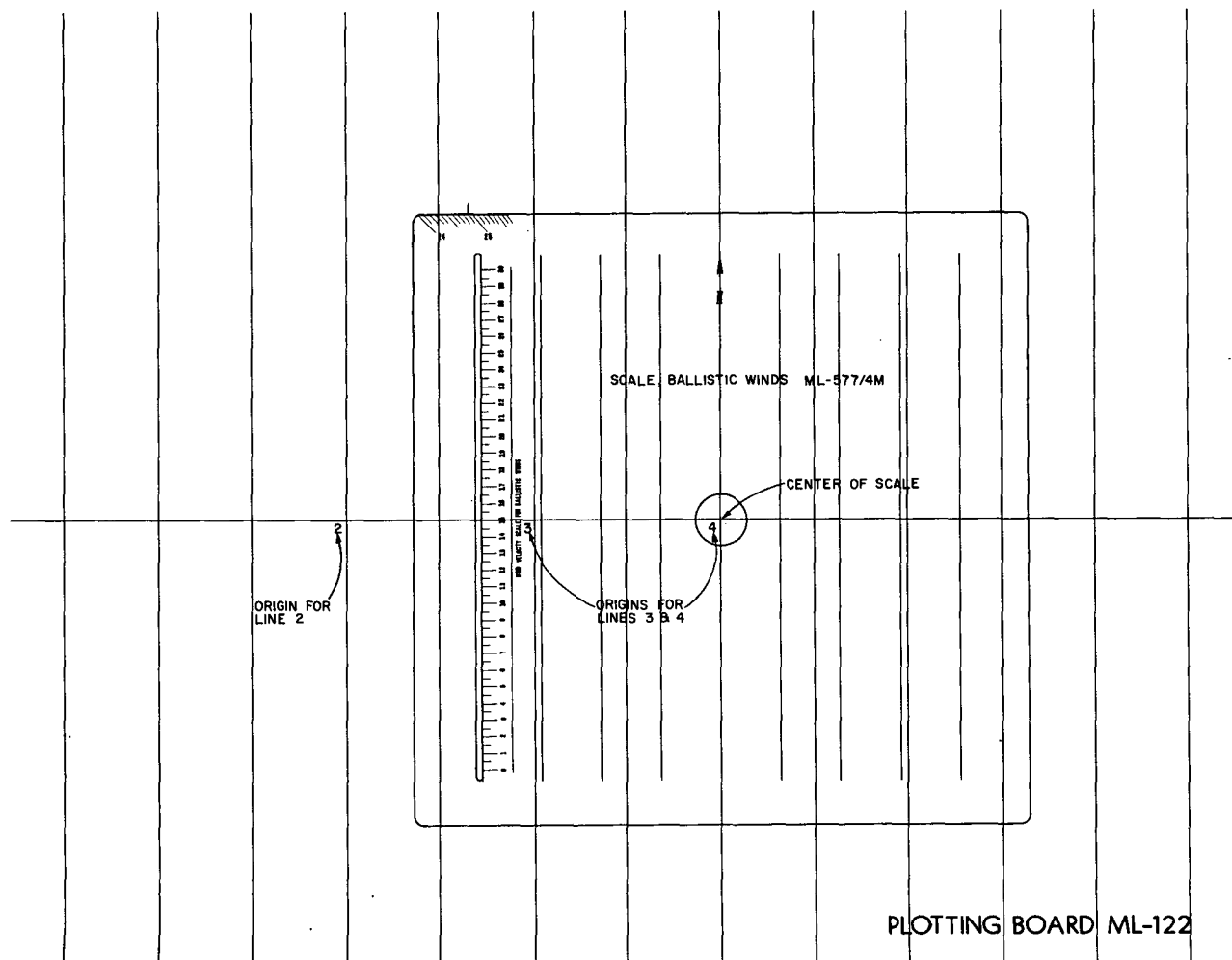

Figure 104. Plotting ballistic wind directions.

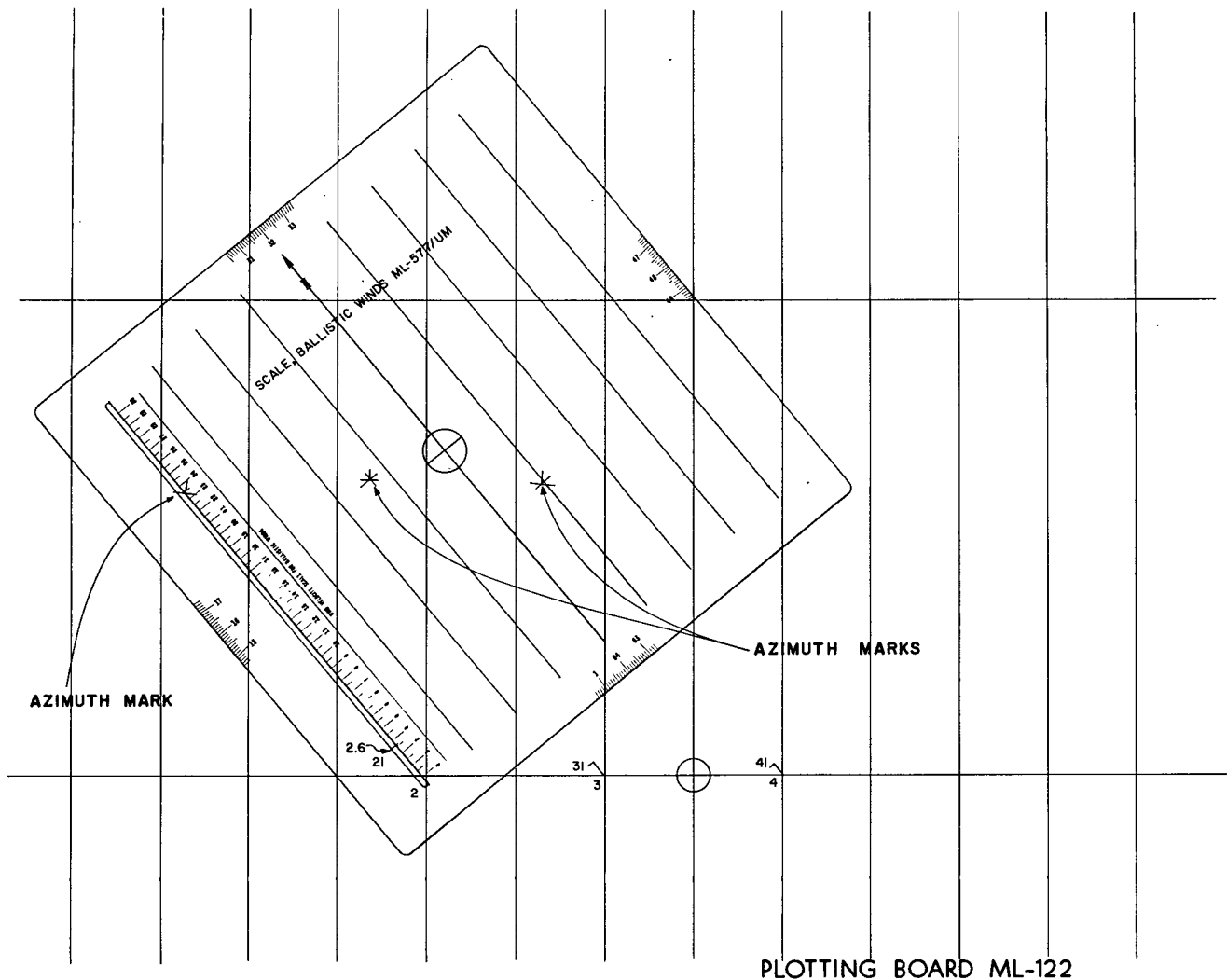

Figure 105. Plotting ballistic wind speeds.

The plot is drawn and identified with a 31, and a small "x" is placed through the azimuth mark. Next, the weighted wind speed is plotted from origin 4 and is identified as 41, etc.

(6) *Plotting zone 2 weighted wind speeds.* The same procedure that was used to plot zone 1 wind direction is used to plot zone 2 wind direction, except that the center of scale ML-577 is alined over the last plot (21, 31, 41, etc). The zone 2 wind direction of 3,160 mils is plotted, and a T-shaped azimuth mark is drawn to indicate direction. The zone 2 weighted wind speed is determined by entering table IIIe for zone 2 with the zone wind speed and the line zone number. In figure 102, the zone 2 wind speed is 12 knots. Therefore, the weighted wind speed for line 2, zone 2 is 9.6 knots. For plot 32, the weighted value is 2.3 knots; for plot 42, the weighted value is 1.4 knots. The weighted wind speeds are deter-

mined and plotted for the remaining lines by placing the zero mark of the ballistic wind velocity scale at the end of the first segment (21, 31, 41, etc) instead of at the origin. An "x" is drawn through the azimuth mark to indicate completion of the plot.

(7) *Completing the ballistic wind plot.* After the zone 2 weighted wind speeds have been plotted, the effects of the zone 3 wind speed on line 3 and above are plotted. To plot these effects, the zone 3 wind direction is plotted in the same manner as the zone 2 wind direction except that the center of the scale is oriented over the end of the segment for each line (32, 42, 52, etc). Then the zone 3 weighted wind speeds are scaled off along the zone wind direction for each of the lines. Similarly, the wind directions and weighted wind speeds for succeeding zones are plotted for the lines they affect. Each plot for a given line origi-

nates from the last point plotted for that line. In this way the weighted wind effects for each zone are combined as vectors to obtain the total effect (fig. 106). When the line and zone number for the plot for any given line coincide and before plotting is continued, the plot for this line is closed out and the ballistic wind direction and speed are measured and recorded in columns (11) and (12) on DA Form 6-46. The ballistic wind speed is measured first by placing the zero of the wind velocity scale on the point of origin and reading the ballistic wind speed at the end of the last plot for that line (fig. 106). The speed is

Figure 106. Measuring ballistic wind speeds.

(Located in back of manual)

read to the nearest 0.1 knot and rounded off to the nearest whole knot. The ballistic wind direction is determined last by extending a line from the point of origin through the last plot. The line must be of sufficient length so that it will extend beyond the outer edge of scale ML-577. The mid-

point of the scale is placed over the point of origin with the north-south lines on the scale parallel to the north-south lines on the plotting board. The direction is read at the point where the extended line passes underneath the outer edge of the azimuth scale. This azimuth is read and recorded to the nearest 100 mils. A completed ballistic wind plot is shown in figure 107.

(8) *Plotting off the board.* When a point extends off the plotting board, the entire plot is moved by changing the origin. The direction and speed of the last point plotted are read from the origin and replotted from the new origin; it is not necessary to replot intermediate points between the origin and the last point.

(9) *Encoding data.* Ballistic winds, columns (11) and (12), DA Form 6-46, are encoded on DA Form 3675 (NATO Met Message) as described in paragraph 154.

Figure 107. Completed ballistic wind plot.

(Located in back of manual)

CHAPTER 8

ENCODING AND TRANSMISSION OF ARTILLERY MET MESSAGES

152. General

★*a. Ballistic Met Message.* Prior to 1961, several types of ballistic meteorological messages were used by the countries of the North Atlantic Treaty Organization (NATO). It was realized that a standard ballistic message was needed during joint combat operations for the common use and exchange of ballistic meteorological data among the allied countries. At a meeting in Paris, France, 7 to 11 November 1960, the External Ballistic Group of the Armaments Committee, NATO, adopted STANAG 4061 which provided for a standard ballistic message to be used by all NATO member nations. Subsequently, the message format has been revised to reflect the changing views of the member nations. STANAG 4061; Edition 3, is scheduled for implementation in early 1971. As a member of NATO, the United States must fulfill its commitment with regard to specific coding procedures associated with the ballistic met message. DA Form 3675 (Ballistic Met Message) (fig. 108), is issued to all U.S. Army artillery met sections for encoding the met message. The use of this form

★METBKQ	LaLaLaLoLoLo (or XXXXXX)
ZZddFF	TTT△△△

★In order that the message may be conveniently transmitted over radio and teletypewriter circuits, it is arranged in six-digit groups. The initial four letters "METB" of the code remain unchanged on each message and are used as a prefix to identify a ballistic meteorological message.

★*b. Definitions of Symbols.* Symbols are defined below in the order in which they appear in the message. Detailed explanations and coding procedures for each symbol are given in paragraph 154.

METB—Identifying prefix for a ballistic meteorological message.

K—Type of message.

Q—Octant of the globe in which the met station is located.

LaLaLaLoLoLo—Location of the met station by

is discussed in paragraph 155. The data in figure 108① are the results of the sample problem computed in chapter 7.

★*b. Computer Met Message.* The computer message differs from the ballistic message in that the zoning structure is different, the zone values are not weighted, pressure is reported instead of density, and the weather elements are reported as zone values. Fire direction center (FDC) personnel insert the met data into the computer, either by a keyboard or punched tape. The computer solves the meteorological portion of the gunnery problem as it computes the ballistic trajectory. STANAG 4082 is scheduled for implementation in early 1971. DA Form 3677 (Computer Met Message) (fig. 109), is issued to all U.S. Army field artillery units for recording the met message. The use of this form is discussed in paragraph 156.

153. The Ballistic Message Code

a. Symbolic Form. The symbolic form of the ballistic message code is—

YYGoGoGoG	hhhPPP
ZZddFF	TTT△△△ ZZddFF (etc.)

(or XXXXXX) latitude and longitude or in clear/coded form.

YY—Date of the observation (Greenwich mean time).

GoGoGo—Beginning of the valid time period in hours and tenths of hours (GMT)

G—Duration of validity in hours. U.S. Forces will always enter 0 since period at validity is not predicted. Other NATO Forces use digits 1-8; code figure 9 indicates 12 hours.

hhh—Altitude (height) of met station in tens of meters.

PPP—Pressure at met station expressed as a percent of standard (1013.25 millibars).

- ZZ—Line number (00 through 15) of the message.
- dd—Ballistic wind direction in hundreds of mils.
- FF—Ballistic wind speed in knots.
- TTT—Ballistic air temperature expressed to the nearest 0.1 percent of ICAO standard.
- △△△—Ballistic air density to the nearest 0.1 percent of ICAO standard.

Each consecutive line number (00 through 15) is always in a ZZ position as shown in the symbolic form (*a* above). The 10 digits after a line number provide ballistic data representative of that portion of the atmosphere from the surface to the top of the standard zone corresponding to the line number (fig. 108). The line number 00 represents the surface; therefore, ballistic data following this number represent surface meteorological conditions.

★154. Encoding of Individual Elements and Groups of the Ballistic Message

The ballistic message is arranged in groups to be conveniently transmitted by radio or teletypewriter.

a. First Group, METBKQ.

(1) METB—The letters "METB" are placed at the beginning of each ballistic meteorological message as an identifying prefix.

(2) K—Either a 2 or a 3, depending on the type of message, is entered in this space. The type-2 message is prepared for surface-to-air trajectories and the type-3 message for surface-to-surface trajectories. If a type-2 message is prepared, a 2 is placed in this space. If a type-3 message is prepared, a 3 is placed in this space.

(3) Q—This digit represents the code for the global octant in which the met section is located. For convenience in determining the geographical location of the reporting met section, the globe has been arbitrarily divided into octants number 0 through 8 (the number 4 is not used) as specified in table 5. If the digit 9 is used in this space, the next group of six digits denotes the clear or coded location of the met station.

★Table 5. Q Code for Octant of Globe

Q Code	Octant location
0	North latitude --- 0° to 90° West longitude
1	North latitude --- 90° to 180° West longitude
2	North latitude --- 180° to 90° East longitude
3	North latitude --- 90° to 0° East longitude
4	Not used
5	South latitude --- 0° to 90° West longitude

- 6 South latitude --- 90° to 180° West longitude
- 7 South latitude --- 180° to 90° East longitude
- 8 South latitude --- 90° to 0° East longitude
- 9 To be used when the location of the met station is not indicated by latitude and longitude.

Note: When the Q code is used, latitude is always given first.

(5) Examples:

★(a) METB 21—Type-2 messages for surface-to-air fire. The met section preparing the message is located in octant 1 of the globe (i.e., at a longitude between 90° and 180° west in the Northern Hemisphere).

(b) METB 33—Type-3 ballistic message for surface-to-surface fire. The met section preparing the message is located in octant 3 of the globe (i.e., at a longitude between 0° and 90° east in the Northern Hemisphere).

★*b.* Second Group, LaLaLaLoLoLo (or XXXX-XX)—The second group of six digits is used to specify the location (to the nearest 6 minutes) of the reporting met station within any particular octant of the globe. The first three spaces are used to encode the latitude and the last three spaces are used to encode the longitude. Examples are explained below.

(1) 405113—For this example, it is assumed the octant 1 is specified in the last space of the previous group. This group shows that the location of the reporting met station within octant 1 is latitude 40° 30' north, longitude 111° 18' west. If the longitude is 100 or over, the first number is dropped. The location in this case cannot be mistaken for longitude 11° 18' west because this longitude is not in octant 1.

(2) 512095—For this example, it is assumed that the octant of the globe is 3. The location of the reporting met station within this octant is latitude 51° 12' north, longitude 9° 30' east. Again, the location cannot be mistaken for longitude 109° 30' east because this longitude is not in octant 3.

★*c.* Third Group, YYGoGoGoG.

(1) YY—These two spaces are used for the Greenwich date (i.e., the day of the current month, 01 through 31) of the observation on which the message is based. The Greenwich date may differ from the local date, depending on the location and the hour. Chart I, FM 6-16, contains the necessary information for conversion from local standard time to Greenwich mean time (GMT).

(2) GoGoGo—These three spaces are used for the Greenwich hour (000 through 239) which represents the beginning of the valid time period.

BALLISTIC MET MESSAGE									
For use of this form, see FM 6-15; the proponent agency is United States Continental Army Command.									
IDENTIFICATION	TYPE MSG	OCTANT	LOCATION		DATE	TIME (GMT)	DURATION (HOURS)	STATION HEIGHT (10's M)	MDP PRESSURE (% OF STD PPP)
METB	K	Q	L _a L _a L _a or xxx	L _o L _o L _o or xxx	YY	G ₀ G ₀ G ₀	G	hhh	PPP
METB	3	1	344	982	17	175	0	036	953
ZONE HEIGHT (METERS)	LINE NUMBER ZZ	BALLISTIC WINDS			BALLISTIC AIR				
		DIRECTION (100's MILS) dd	SPEED (KNOTS) FF	TEMPERATURE (% OF STD) TTT	DENSITY (% OF STD) ΔΔΔ				
SURFACE	00	31	04	052	902				
200	01	25	13	048	907				
500	02	30	12	040	914				
1000	03	34	12	029	920				
1500	04	35	11	032	922				
2000	05	41	08	031	920				
3000	06	44	12	024	924				
4000	07	51	10	029	925				
5000	08	54	11	029	925				
6000	09	54	13	035	928				
8000	10	57	09	035	934				
10000	11	49	07	035	942				
12000	12	44	09	035	941				
14000	13	44	10	035	944				
16000	14	50	08	035	949				
18000	15	53	07	035	950				
REMARKS									
DELIVERED TO: RECEIVED FROM: S-3, 3D INF DIV ARTY						TIME (GMT) 1835		TIME (LST) 1335	
MESSAGE NUMBER 3					DATE 17 FEB 64				
RECORDER WIGGONS					CHECKED SHANNON				

DA FORM 3675
1 JAN 71

REPLACES DA FORM 6-57, 1 MAR 62, WHICH IS OBSOLETE.

①
★Figure 108. DA Form 3675 (Ballistic Met Message).

THE BALLISTIC MET MESSAGE IS ENCODED AS FOLLOWS

1. The Ballistic Met Message is arranged to be conveniently transmitted by radio or teletypewriter in groups of six digits or letters.

2. Information data: The first four letters denote that the message is a ballistic met message. The next letter denotes the type of ballistic met message; 2 — surface to air trajectories or 3 — surface to surface trajectories. The sixth digit is the "Q" code of the global octant location of the met station and the following six digits denote the location of the met station in degrees and tenths of degrees. When 9 of the "Q" code is used, the following six digits denote the clear or coded location of the met station. The third group of six digits denote the day of the observation, time of commencement of validity in hours and tenths of hours (Greenwich Mean Time) and duration of validity, in hours from 1 to 8; code figure 9 indicates 12 hours (Note: US Forces will always use 0 since period of validity is not predicted.). The fourth group of six digits denote the station height and the station pressure expressed in percent of standard ICAO pressure. All succeeding groups of six are ballistic data.

3. The following specimen message was transmitted by teletypewriter:

METB31 625468 290250 025001 000701

860163 015510 863162

EXPLANATION:

Group 1 Met Msg for surface to surface fire, type 3 message. The Met Station located in global octant Nr 1.

Group 2 Center of the area of applicability of the message (station location) 62°30'N; 146°48'W.

Group 3 29th day of the month. Valid time commences at 0230 hours GMT. Period of validity is not predicted by US units.

Group 4 Met station is 250 meters above mean sea level. Station pressure is 100.1% of standard ICAO pressure.

Group 5 Line 00 (surface) ballistic wind direction is 700 miles and wind speed is 1 knot.

Group 6 For line 00, the ballistic temperature is 86.0% of standard and the ballistic density is 116.3% of standard.

Group 7 Line 01, (0 — 200 meters) ballistic wind direction 5500 miles and wind speed is 10 knots.

Group 8 For line 01, the ballistic temperature is 86.3% of standard and ballistic density is 116.2% of standard.

Q Code for Octant of Globe

0 — North latitude	0 — 90 West longitude
1 — " "	90—180 West "
2 — " "	180—90 East "
3 — " "	90 — 0 East "
4 — Not used	
5 — South latitude	0 — 90 West longitude
6 — " "	90—180 West "
7 — " "	180—90 East "
8 — " "	90 — 0 East "
9 —	Used when the location of the meteorological station is not indicated by latitude and longitude.

★ Figure 108—Continued.

This time corresponds to the time of release of the radiosonde flight.

(3) *Duration of validity in hours.* U.S. Forces will always enter Q in this space since periods of validity for the data contained in meteorological messages for ballistics purposes is not predicted. During combat U.S. Forces normally provide new data on a two-hour schedule. Other NATO Forces use digits 1-8; code figure 9 indicates 12 hours.

(4) *Examples:*

(a) 150910—The observation on which the message is based was taken on the 15th day of the current month. The beginning of the valid time period for this message is 0906 hours (GMT).

(b) 271510—The observation was taken on the 27th day of the current month. The beginning of the valid time period for this message is 1506 hours (GMT).

d. Fourth Group, hhhPPP.

(1) *hhh*—These three spaces are used for entering the altitude of the met station which prepared the message (i.e., the altitude of the meteorological datum plane (MDP)). The altitude is expressed in tens of meters above mean sea level.

(2) *PPP*—The last three spaces of the fourth group are used for entering the station atmospheric pressure expressed to the nearest 0.1 percent of ICAO standard (percent of 1013.25 millibars). The station pressure is first read in millibars from the barometer. This pressure is then converted to percent by using chart VI, FM 6-16. For example, the station pressure is 950 millibars. In chart VI, FM 6-16, 950 millibars is equivalent to 93.8 percent of standard.

(3) *Example: 033938*—The met station is 330 meters above mean sea level. The station pressure, expressed as a percent of ICAO standard, is 93.8 percent. The first digit is dropped when the pressure exceeds 100 percent.

★*e. Fifth Group, ZZddFF.* The six-digit groups which follow the fourth group provide meteorological ballistic data.

(1) *ZZ*—These two spaces are used to enter the line number which identifies the reported ballistic information with the appropriate atmospheric layer. The line numbers begin with 00 (surface) and are numbered consecutively through 15 in conjunction with the 15 standard altitude zones for a ballistic message.

(2) *dd*—The true direction from which the ballistic wind is blowing is reported by these two

spaces. The direction is reported in hundreds of mils. This ballistic wind direction is representative of the atmosphere from the surface to the top of the standard zone corresponding to the line number for this group. The procedure for determining ballistic wind direction is described in detail in paragraph 151.

(3) *FF*—These two spaces are used for encoding the ballistic wind speed in knots. This wind speed represents the atmospheric winds from the surface to the top of the standard zone corresponding to the line number for this group. The procedure for determining ballistic wind speed is described in paragraph 151.

(4) *Examples:*

(a) 053117—The ballistic wind direction for line number 5 is 3,100 mils. The ballistic wind speed for line number 5 is 17 knots. Thus, the ballistic wind representing the atmosphere from the surface to 2,000 meters (the top of zone 5) is blowing from 3,100 mils at a speed of 17 knots.

(b) 104551—The ballistic wind representing the atmosphere from the surface to 8,000 meters (the top of zone 10) is blowing from 4,500 mils at a speed of 51 knots.

★*f. Sixth Group, TTT△△△.* The six spaces of the sixth group are used to report ballistic air temperature (TTT) and ballistic air density (△△△) for the line number shown in the sixth group. Each subsequent line of the message will furnish information in group ZZddFF and group TTT△△△ for the altitude of that line number. Thus, each line number is followed by 10 digits which provide the ballistic wind, ballistic air temperature, and ballistic air density for the altitude indicated by that line number.

(1) *TTT*—The ballistic air temperature is reported in these three spaces. This temperature is expressed to the nearest 0.1 percent of ICAO standard. If the temperature value is over 100 percent, the first digit is dropped. The procedure for determining the ballistic temperatures is described in paragraph 143.

(2) *△△△*—The ballistic air density is reported in these three spaces. This density is expressed to the nearest 0.1 percent of ICAO standard. If the density value is over 100 percent, the first digit is dropped. The procedure for determining the ballistic air density is described in paragraph 144.

(3) *Examples:*

(a) 973036—For the line number of the previous six-digit group, the ballistic air temper-

ature is 97.3 percent of standard, and the ballistic density is 103.6 percent of standard.

(b) 111899—For the line number of the previous six-digit group, the ballistic air temperature is 111.1 percent of standard, and the ballistic density is 89.9 percent of standard. This temperature value cannot be mistaken for 11.1 percent because that would obviously be too low to be realistic. Normally, ballistic temperature and density values will not depart radically from 100 percent.

★155. DA Form 3675. (Ballistic Met Message)

a. DA Form 3675, (fig. 108 ①) is used by U.S. Army artillery met sections for encoding the NATO ballistic message. This form is arranged so that the data appear in the sequence of the symbolic code for the message. The first four groups of the message METBKQ through hhh-PPP, are the introduction. As soon as these data are determined by the meteorological personnel, they are entered in the appropriate spaces across the top of DA Form 3675. Below the introduction, the form is divided into six columns for zone height, line number, ballistic wind direction, ballistic wind speed, ballistic air temperature, and ballistic air density. As the ballistic data for each line number are determined, they are entered in the appropriate columns. Below the ballistic data columns a space is provided for any remarks deemed appropriate, such as a comment on any unusual data in the message. At the bottom of the form, spaces are provided for entering the unit(s) to whom the message was sent or from whom the message was received, the time the message was sent or received, the date, the message number (numbered consecutively each 24-hour period), the name of the person recording the message, and the name of the person who checked the data for accuracy.

b. On the back of DA Form 3675 (fig. 108 ②) a sample ballistic message is shown and the encoding is explained. Also shown is the information for encoding the octant of the globe.

156. The Computer Message Code

★a. *Symbolic Form.* The symbolic form of the computer message code is—

METCMQ LaLaLaLoLoLo (or XXXXXX)
 YYGoGoGoG hhh PdPdPd ZZddd FFF TTTT
 PPPP ZZddd FFF TTTT PPPP (etc.)

b. *Definitions of Symbols.* Symbols are defined below in the order in which they appear in the message. Detailed explanations and coding pro-

cedures for each symbol are given in paragraph 157.

METCM—Identifying prefix for a computer meteorological message.

Q—Octant of the globe in which the met station is located.

LaLaLaLoLoLo—Location of the met station by (or latitude and longitude or in XXXXXX) clear/coded form.

YY—Date of the observation (Greenwich mean time).

GoGoGo—Beginning of the valid time period in hours and tenths of hours (GMT).

G—Duration of validity in hours. U.S. forces will always enter 0 since period of validity is not predicted. Other NATO forces use digits 1-8, code figure 9 indicates 12 hours.

hhh—altitude (height) of met station in tens of meters.

PdPdPd—Pressure at met datum plan (MDP) in millibars.

ZZ—Line number (00 through 26) of the message.

ddd—True wind direction in tens of mils.

FFF—True wind speed in knots.

TTTT—Air temperature expressed to the nearest 0.1° Kelvin.

PPPP—Air pressure to the nearest millibar.

Each consecutive line number (00 through 26) is always in a ZZ position as shown in the symbolic form (a above). The 14 digits after a line number provide true data representative of that zone of the atmosphere from the surface up to 20,000 meters.

157. Encoding of Individual Elements and Lines of the Computer Message

The computer message is arranged in lines to be conveniently transmitted by radio teletypewriter.

★a. *First Line, METCMQ LaLaLaLoLoLo (or XXXXXX).*

(1) METCM—The letters "METCM" are placed at the beginning of each computer message as an identifying prefix.

(2) Q—This space represents the global octant in which the met section is located. For convenience in determining the geographical location of the reporting met section, the globe has been arbitrarily divided into octants numbered 0 through 8 (the number 4 is not used) as spe-

cified in table 5. An octant number of 9 is used to indicate that the next group of six digits is a special coded location.

Examples:

(a) *METCM1*—The met section preparing the message is located in octant 1 of the globe (i.e., at a longitude between 90° and 180° west in the Northern Hemisphere).

(b) *METCM3*—The met section preparing the message is located in octant 3 of the globe (i.e., at a longitude between 0° and 90° east in the Northern Hemisphere).

(3) *LaLaLaLoLoLo* (or *XXXXXX*)—These six spaces are used to specify the location (to the nearest 6 minutes) of the reporting met station within any particular octant of the globe. The first three spaces are used to encode the latitude and the last three spaces are used to encode the longitude. Examples are explained below.

(a) *405113*—For this example, it is assumed that octant 1 is specified in the last digit of the previous group. This group shows that the location of the reporting met station within octant 1 is latitude 40° 30' north, longitude 111° 18' west. If the longitude is 100 or over, the first number is dropped. The location in this case cannot be mistaken for longitude 11° 18' west because this longitude is not in octant 1.

(b) *512095*—For this example, it is assumed that the octant of the globe is 3. The location of the reporting met station within this octant is latitude 51° 12' north, longitude 9° 30' east. Again, the location cannot be mistaken for longitude 109° 30' east because this longitude is not in octant 3.

(c) When the met station is identified by a code word, number 9 of the Q code is used. When specified in the appropriate SOP, the location may be indicated to the nearest 1,000 meters by UTM grid coordinates.

★*b. Second Line, YYGoGoGoG hhh PdPdPd.*

(1) *YY*—These two spaces are used for reporting the Greenwich date (i.e., the date of the current month, 01 through 31) of the observation on which the message is based. The Greenwich date may differ from the local date, depending on the location and the hour. Chart I, FM 6-16, contains the necessary information for conversion from local standard time to Greenwich mean time (GMT).

(2) *GoGoGo*—These three spaces are used for reporting the Greenwich hour and tenth of hour (000 through 239) which represents the beginning of the valid time period. This time corres-

ponds to the time of release of the radiosonde flight.

(3) *G*—Duration of validity in hours. U.S. Forces will always enter 0 in this space since periods of validity for the data contained in meteorological messages for ballistic purposes is not predicted. During combat, U.S. Forces normally provide new data on a two-hour schedule. Other NATO forces use digits 1-8, code figure 9 indicates 12 hours.

(4) *hhh*—These three spaces are used for entering the altitude of the met station which prepared the message (i.e., the altitude of the meteorological datum plane (MDP)). The altitude is expressed in tens of meters above mean sea level.

(5) *PdPdPd*—These three spaces are used to enter the met datum plane (MDP) pressure in millibars, encoded in three digits. When the MDP pressure exceeds 1000, the thousandths digit is dropped.

★*c. Remaining Lines, ZZdddFFFTTTTPPPP.* The digits in the remaining lines represent surface and/or zone meteorological data.

(1) *ZZ*—These two spaces are used to enter the line number which identifies the reported meteorological information with the appropriate atmospheric layer. The line numbers begin with 00 (surface) and are numbered consecutively through 26 in conjunction with the 26 standard altitude zones for a computer message.

(2) *ddd*—The true direction from which the wind is blowing is reported in these three spaces. The direction is reported in tens of mils. Examples are explained below:

(a) *320*—The true direction of the wind is 3200 mils.

(b) *318*—The true direction of the wind is 3180 mils.

(3) *FFF*—These three spaces are used for encoding the true wind speed in knots. Examples are explained below:

(a) *007*—The true wind speed is seven knots.

(b) *026*—The true wind speed is 26 knots.

(4) *TTTT*—The air temperature is reported in these four spaces. This temperature is expressed to the nearest 0.1 degree Kelvin. Example: *2773* is an air temperature of 277.3° Kelvin.

(5) *PPPP*—The air pressure is reported in these four spaces. This pressure is expressed to the nearest millibar.

158. DA Form 3677 (Computer Met Message)

★*a.* DA Form 3677 (Computer Metro Message) (fig. 109①) is used by U.S. Army artillery met sections for encoding the computer met message. This form is arranged so that the data appear in the sequency of the symbolic code for the computer message. The first line of the form, METCM through PdPdPd, is the introduction. As soon as these data are determined by the meteorological personnel, they are entered in the appropriate spaces across the top of DA Form 3677. Below the introduction, the form is divided into six columns for zones height, line number, wind direction, wind speed, air temperature, and air pressure. As the data for each line number are determined, they are entered in the appropriate columns. At the bottom of the form spaces are provided for entering the unit(s) to whom the message was sent or from whom the message was received, the date and the time of day the message was sent or received, the message number and the names of the persons who recorded and checked the message.

★*b.* On the back of DA Form 3677 (fig. 109②) a sample computer message is shown and the encoding is explained. Also shown is the information for encoding the octant of the globe.

159. Transmission of the Met Message

a. General. Since meteorological data are changeable, timely distribution of the met message in a usable form is essential. Any expeditious means may be used to transmit met messages to the firing units. However, within current communications capabilities certain modes are especially suited for transmission of the met message.

b. Radio teletypewriter (RATT). Each artillery met section within the field army will be equipped with a radio teletypewriter. RATT is considered the primary mode for transmission of the met message. In addition to being a rapid and efficient means of communications, the recipient is provided a typed copy of the transmitted message, as well as a punched tape. When preparing the computer met message for transmission, the radio teletypewriter operator must follow the procedures outlined below and in the same problem which follows. Any deviations from these procedures will cause the computer to reject the computer met message.

(1) The procedures for cutting the computer met message tape for transmission are as follows:

(*a*) *Step 1.* Prepare the message heading, using standard RATT procedures.

(*b*) *Step 2.* Advance the tape 4 to 5 inches by means of the tape advance lever or the blank key on the TT-76 teletypewriter. This blank section of the tape is used by the computer operator to thread the computer met message into the FADAC mechanical tape reader.

(*c*) *Step 3.* Cut the text of the message; i.e., the identification lines and the met data lines of the computer met message. In cutting these lines the RATT operator must use only *one carriage return* and one line feed at the end of each line. Placing more than *one* carriage return instruction at the end of any line will cause the computer to stop entering data through the mechanical tape reader.

(*d*) *Step 4.* Cut the digit nine (9) and one carriage return instruction after cutting the last line of available met data. The digit nine informs the computer that it has reached the end of the computer met message.

(*e*) *Step 5.* Advance the tape 2 and 3 inches by means of the tape advance lever or the blank key on the TT-76 teletypewriter. This is to provide some separation between the text and the ending.

(*f*) *Step 6.* Cut two carriage return instructions. Then cut the ending of the message.

(2) *Sample Problem: Computer Met Message Radio Teletypewriter Procedures.*

c. Dissemination of Met Data.

(1) The division artillery met section will operate in three radio nets.

(*a*) The corps artillery met net, AM (RATT), is the basic net for *all* met sections in the corps sector. The division artillery met section operates in this external net to insure comprehensive and coordinated meteorological coverage of the corps area. The primary use for this net will be to disseminate fallout messages, sound ranging data, met data for U.S. Air Force Air Weather Service (AWS) detachments, ballistic and computer messages to other met sections for further transmission to their supported FDC's, to coordinate radiosonde frequencies and to schedule soundings.

(*b*) Division artillery command/fire direction net 1, AM (RATT), and division artillery command/fire direction net 2, AM (RATT), are used by the division artillery met section as required. The only data that normally will be transmitted over any command/fire direction net, AM (RATT) by a met section is ballistic and computer messages to a supported FDC. However,

COMPUTER MET MESSAGE								
For use of this form, see FM 6-15; the proponent agency is United States Continental Army Command.								
IDENTIFICATION	OCTANT	LOCATION		DATE	TIME (GMT)	DURATION (HOURS)	STATION HEIGHT (10's M)	MDP PRESSURE MB's
METCM	Q	L _a L _a L _a or xxx	L _o L _o L _o or xxx	YY	G _o G _o G _o	G	hhh	P _d P _d P _d
METCM	1	344	982	17	175	0	036	966
ZONE HEIGHTS (METERS)	LINE NUMBER ZZ	ZONE VALUES						
		WIND DIRECTION (10's M) ddd	WIND SPEED (KNOTS) FFF	TEMPERATURE (1/10°K) TTTT	PRESSURE (MILLIBARS) PPPP			
SURFACE	00	310	004	3030	0966			
200	01	249	013	3012	0955			
500	02	316	012	2966	0928			
1000	03	361	013	2899	0886			
1500	04	371	011	2882	0834			
2000	05	503	008	2854	0786			
2500	06	455	015	2818	0689			
3000	07	473	014	2762	0695			
3500	08	520	014	2751	0653			
4000	09	581	018	2723	0612			
4500	10	578	018	2696	0575			
5000	11	567	016	2666	0539			
6000	12	572	015	2618	0488			
7000	13	587	009	2559	0428			
8000	14	611	010	2503	0373			
9000	15	355	012	2444	0325			
10000	16	396	015	2385	0282			
11000	17	383	015	2326	0244			
12000	18	379	026	2273	0210			
13000	19	393	020	2199	0180			
14000	20	438	016	2123	0154			
15000	21	625	017	2073	0131			
16000	22	002	018	2077	0111			
17000	23	632	025	2063	0094			
18000	24	075	035	2069	0079			
19000	25	104	026	2125	0070			
20000	26	156	031	2117	0059			
FROM TO	S-3, 3D INF DIV ARTY			DATE & TIME (GMT)	1835	DATE & TIME (LST)	1335	
MESSAGE NUMBER	3			RECORDER	WITHERINGTON	CHECKED	MILLER	

DA FORM 3677
1 JAN 71

REPLACES DA FORM 6-59, 1 MAR 62, WHICH IS OBSOLETE.

★Figure 109. DA Form 3677 (Computer Met Message).

COMPUTER MET MESSAGE IS ENCODED AS FOLLOWS

1. The message is arranged in groups to be conveniently transmitted by radio or teletypewriter.

2. Information data: In the first group, the first five letters denote that the message is a computer message and the digit denotes the "Q" code of the global octant of the met station. The next group of six digits denote the location of the met station in degrees and tenths of degrees. When 9 of the "Q" code is used, the six digits denote the clear or coded location of the met station. The third group of digits denote the day of the month, time of commencement of validity in hours and tenths of hours (Greenwich Mean Time) and duration of validity, in hours from 1 to 8; code figure 9 indicates 12 hours. (Note: US Forces will always use Q since period of validity is not predicted.) The first three digits of the 4th group denote the height of the met station (Met Datum Plane) above sea level in multiples of 10 meters. The other three digits of the group denote the station pressure (MDP) in millibars. The succeeding groups of eight digits are zone values, two groups for each line of the message.

3. The following specimen message was transmitted by teletypewriter.

METCM1 347983 081450 123903 00451025
 29310903 01454027 29200892

Q Code for Octant of Globe

0 - North latitude	0 - 90 West longitude
1 - " "	90-180 West "
2 - " "	180-90 East "
3 - " "	90 - 0 East "
4 - Not used	

5 - South latitude	0 - 90 West longitude
6 - " "	90-180 West "
7 - " "	180-90 East "
8 - " "	90 - 0 East "
9 - Used when the location of the meteorological station is not indicated by latitude and longitude.	

EXPLANATION:

- Group 1 Computer message. Met Station located in global octant Nr 1. (N Lat 90° - 180°W).
- Group 2 Center of area of applicability of the message (station location) is 34°42'N; 98°18'W.
- Group 3 8th day of the month. Valid time commences at 1430 hours GMT. Period of validity is not predicted by US units.
- Group 4 Met Station is 1230 meters above MSL. The MDP pressure is 903 millibars.
- Group 5 & 6 At the surface (line 00) the wind direction is 4510 mils, wind speed is 25 knots. The surface temperature is 293.10 Kelvin and surface pressure is 903 millibars.
- Group 7 & 8 For line 01 (0-200 meters) the zone wind direction is 4540 mils and wind speed is 27 knots. Zone temperature is 292.0° Kelvin and zone pressure is 892 millibars.

★ Figure 109—Continued.

Message parts	Sample message	Standard FADAC message machine functions	Remarks
Beginning message machine functions		5 Spaces 2 CR	CR= Carriage returns LF= Line feed
HEADING	5 GRR DE A4RC P100915S FM A4RC TO RGR5 RC6R G5RC GRNC BT	2 CR, 2 LF 2 CR, 2 LF 2 CR, 2 LF 2 CR, 2 LF 2 CR, 2 LF 2 CR, 2 LF 2 CR, 2 LF 2 CR, 2 LF	
TEXT	COMPUTER MET MESSAGE	Advance the tape 4 to 5 inches by means of the BLANK key on the TT-76 Teletypewriter.	Blank tape is used to thread the computer met message into the mechanical tape reader.
		METCM1344982 171820036967	1 CR, 1 LF 1 CR, 1 LF Identification line 12 spaces.
		0031000430470967 0124901330290957 0231601229800930 * * * * * 2615603121170061	1 CR, 1 LF 1 CR, 1 LF 1 CR, 1 LF * * * * * 1 CR, 1 LF The carriage return code causes the computer to store the previous 16 digits.
		9	1 CR The digit 9 is a stop instruction for the computer.
		Advance the tape 3 to 4 inches by means of the BLANK key on the TT-76 Teletypewriter.	
ENDING	BT NNNN LTRS key	2 CR, 2 LF 2 CR, 2 LF Struck 12 times	

Note. The radio teletypewriter operator must follow the procedures exactly as outlined above when preparing the computer met message for transmission. Any deviations from this procedure will cause the computer to reject the computer met message and to request entry of the computer met message through the FADAC keyboard.

any data and or information required to maintain operational integrity may be transmitted over a command/fire direction net AM (RATT). Ballistic and computer messages will be transmitted upon request or as scheduled.

(2) The field artillery target acquisition battalion (FATAB) met sections will operate in the corps artillery met net, AM (RATT).

(a) Whenever possible one of the FATAB met sections will be designed as net control station for the corps artillery met net. Normally, this will be the rear FATAB met section; however, a division artillery met section may be designated as the net control station when this section is operating in the rear of the corps area to furnish fallout messages and met data for the Air Weather Service (AWS). The rear FATAB met section will also operate in the corps artillery command/fire direction net, AM (RATT), when

transmitting ballistic and computer messages to corps artillery and other artillery units under corps artillery.

(b) The forward FATAB met section will operate in a manner similar to that of a division artillery met section. In addition to the corps artillery met net, AM (RATT), the forward FATAB met section operates in an appropriate command/fire direction net, AM (RATT), to transmit ballistic and computer messages, and for command and administrative control. For example, if the forward FATAB met section is employed in support of a field artillery group, it will transmit ballistic and computer messages over the field artillery group command/fire direction net, AM (RATT).

(c) Met data for nondivisional artillery units are transmitted over the corps artillery met net, AM (RATT), either upon request or by schedule. Corps and army artillery units in posi-

tion within a division combat zone may obtain met data from the nearest division artillery battalion or division artillery FDC, over a division artillery command/fire direction net, AM (RATT), or from the division artillery met section over the corps artillery met net, AM (RATT).

(3) Messages and all flight data collected for the computations of this message will be retained and kept in a monthly file. The monthly file is kept until the 15th day of the second month following and is then destroyed. For example, the January file will be destroyed on 15 March.

160. Requests for Met Messages

As a result of NATO Standardization Agreement 4103, a standard format for requests of ballistic met messages between NATO forces has been established. The request provides information as to the type of message desired, location of requesting unit, date and time of first message, intervals between messages, lowest and highest lines required, and time of termination of request.

a. Message Structure. The message structure is—

Group 1	METRKQ
Group 2	LaLaLaLoLoLo or XXXXXX
Group 3	Y _o Y _o G _o G _o G ₁ G ₁
Group 4	Z _o Z _o Z ₁ Z ₁ J _o J ₁

★*b. Definitions of Symbols.* Symbols are defined below in the order in which they appear.

MET—Identifying prefix for a ballistic met message.

R—Request.

K—Type of message (2 for surface-to-air fire; 3 for surface-to-surface fire; 9 for computer message).

Q—Octant of the globe in which requesting unit is located.

LaLaLa—Latitude of requesting unit to the nearest tenth of a degree.

L_oL_oL_o—Longitude of requesting unit to the nearest tenth of a degree.

XXXXXX—Location of requesting unit in clear or code.

Y_oY_o—Day of month (GMT) on which delivery of first message is required.

G_oG_o—GMT time, to the nearest hour, of day Y_oY_o at which delivery of the first met message is required.

G₁G₁—GMT time, to the nearest hour, on the last day on which final message is required.

Z_oZ_o—Lowest line required in the message when K=2 or 3; 00 is entered when K=9.

Z₁Z₁—Highest line required in the message when K=2 or 3; the highest zone code is entered when K=9.

J_o—The number of days from 0 to 9 which must be added to Y_oY_o to find the last day for which met message support is required. The hour of the last day is determined by G₁G₁ above.

J₁—Time interval, in hours, between messages. Numbers 1 through 8 indicate hourly intervals; 9 indicates a 12 hour interval. When only one message is required G₁G₁ is the same as G_oG_o and J_o and J₁ are 0.

c. Example. Following is an example of a request for a met message and an interpretation of the example.

```
METR31
345983
050816
000624
```

(1) Group 1. Ballistic met message is requested for surface-to-surface fire applicable to the northern hemisphere between 90° W and 180° W. (The octant code is explained in table 5 above.)

(2) Group 2. The location of the requesting unit is 34° 30' N. and 98° 18' W.

(3) Group 3. Delivery of the first message is required on the fifth day of the month at 0800 GMT. Delivery of the last message is required at 1600 on the seventh day of the month (for determination of the seventh day, see group four below).

(4) The lowest line requested is 00 and the highest line requested is 06. In addition to day Y_oY_o, the message is required for two additional days. (In this message, met information is requested for the 5th (original day), 6th and 7th day (two additional days).) The time interval between messages is four hours.

CHAPTER 9

DETERMINATION OF NATO DENSITIES AND TEMPERATURES
FROM SURFACE OBSERVATIONS**161. Surface Observations**

a. General. The use of electronic equipment is the primary means of determining ballistic densities and temperatures. However, it may become necessary to use the departure method when the electronic equipment fails or a shortage of expendables exists and there is no other electronic met section in the vicinity. In the departure method, the ballistic air densities and temperatures are determined from surface observations of pressure, air temperature, and wet-bulb depression when the met station height above sea level and the times of sunrise and sunset are known. This method is not applicable for producing the computer met message.

b. Recording Observations. The surface data initially recorded on DA Form 6-50 (Ballistic Density From Surface Data) (fig. 110), are used to determine ballistic density for each line of the message. Ballistic data are computed on DA Form 6-50 and transferred to DA Form 3675 (NATO Met Message).

c. Pressure. The station pressure at the station is recorded to the nearest millibar. If the station pressure is read in inches of mercury, it is read to the nearest 0.01 inch and converted to millibars by using chart X, FM 6-16. The station pressure in millibars is converted to percent of ICAO standard by using chart VI, FM 6-16.

d. Temperature. Both the wet-bulb and dry-bulb temperatures are measured to the nearest 0.1° Celsius with the psychrometer ML-224 (para 52).

e. Station Altitude. The altitude of the station is determined to the nearest 10 meters above sea level from a contour map of the area or by survey (para 101) and is recorded in tens of meters.

f. Time of Sunrise and Sunset. Times of sunrise and sunset may be obtained from the Air Weather Service detachment, the S2, or the division or corps survey information center (SIC).

162. Determining Ballistic Temperature

a. When the surface observation technique is

used the same ballistic air temperature is used for each line number of the message. This temperature value is expressed to the nearest 0.1 percent of ICAO standard. After the surface temperature has been determined this same value is entered in the appropriate spaces for the remaining lines of the message. Since the temperatures aloft are not actually measured, the assumption is made that the temperature changes with height in accordance with the standard ICAO atmosphere lapse rate. Thus, the ballistic temperature (as a percent of ICAO standard) will remain unchanged for successive line numbers.

b. The virtual temperature is recorded on DA Form 6-50 in degrees Celsius and percent of ICAO standard. The ballistic temperature (surface virtual temperature), is determined by subtracting the wet-bulb temperature in block (3), DA Form 6-50 (fig. 111), from the dry-bulb temperature in block (2) to the nearest 0.1° C. The difference is the wet-bulb depression, which is entered in block (4). Table Ia, FM 6-16, is entered with the dry-bulb temperature and the wet-bulb depression to determine the surface virtual temperature to the nearest 0.1° C. The virtual temperature is entered in block (5). The virtual temperature in degrees Celsius is converted to the nearest 0.1 percent of standard by using chart XII, FM 6-16.

163. Use of Departure Tables

a. General. Research in climatology has indicated that a correlation exists between the density at the surface and the densities aloft. The procedure for computing the ballistic densities is based on the use of climatological tables which contain the values of the upper air densities corresponding to specific regions of the world, time of day, and measured surface conditions. Tables are provided for both surface-to-surface (type-3) and surface-to-air (type-2) ballistic messages. In the tables, the values of density are expressed as a percent of standard ICAO atmosphere.

BALLISTIC DENSITY FROM SURFACE DATA FM 6-15												
STATION			LOCATION				RE- LEASE TIME	DATE		FLIGHT NR.		
<i>3d Div Arty</i>			<i>Fort Sill, Okla</i>					(1) SURFACE PRESSURE	LST	8 APR 60	1400	<i>3</i>
									GMT	9 APR 60	2000	
(8) TYPE MESSAGE			S		A		INCHES		MSL % STD (ICAO) <i>76.5</i>			
BALLISTIC							MILLIBARS <i>978</i>					
(9) REGION							TEMPERATURE		(2) DRY <i>20.2°C</i>			
(10) PERIOD									(3) WET <i>16.3°C</i>			
Night			Afternoon		Transition				(4) DEPRESSION °C			
(11) TRUE SURFACE DENSITY							(5) VIRTUAL °C		%STD			
(12) MEAN SURFACE DENSITY							(6) STATION HEIGHT (10's METERS) <i>036</i>					
(13) DEPARTURE FROM MEAN SURFACE DENSITY							(7) SUNRISE <i>0611</i>		SUNSET <i>1901</i>			
Lines	DEPARTURE FROM MEAN BALLISTIC DENSITY (14)			BALLISTIC DENSITY % (15)			COMPUTATIONS					
1												
2												
3												
4												
5												
6												
7												
8												
9												
10												
11												
12												
13												
14												
15												
OBSERVER			COMPUTER				CHECKER					

DA FORM 6-50, 1 MAR 62

PREVIOUS EDITION OF THIS FORM IS OBSOLETE.

Figure 110. Recording initial data on DA Form 6-50.

BALLISTIC DENSITY FROM SURFACE DATA FM 6-15											
STATION			LOCATION				RE- LEASE TIME	DATE	HOUR	FLIGHT NR.	
<i>3d Div Arty</i>			<i>FORT SILL, OKLA</i>								
							GMT	<i>8 APR 60</i>	<i>2000</i>		
1	(8) TYPE MESSAGE						(1) SURFACE PRESSURE	INCHES		MSL % STD (ICAO) <i>96.5</i>	
	BALLISTIC		S					A	MILLIBARS		
2	(9) REGION							TEMPERATURE	(2) DRY		
	1	2	3	4	5	6	7		<i>20.2 °C</i>		
(10) PERIOD							(3) WET				
Night		Afternoon			Transition		<i>16.3 °C</i>				
(11) TRUE SURFACE DENSITY							(4) DEPRESSION				
(12) MEAN SURFACE DENSITY							(5) VIRTUAL			<i>22.0 °C 102.4 %STD</i>	
(6) STATION HEIGHT (10's METERS)							<i>036</i>				
4	(13) DEPARTURE FROM MEAN SURFACE DENSITY					(7) SUNRISE		SUNSET			
					<i>0611</i>		<i>1901</i>				
Lines	DEPARTURE FROM MEAN BALLISTIC DENSITY (14)				BALLISTIC DENSITY % (15)			COMPUTATIONS			
1											
2											
3											
4											
5											
6											
7											
8											
9											
10											
11											
12											
13											
14											
15											
OBSERVER				COMPUTER				CHECKER			

DA FORM 6-50, 1 MAR 62

PREVIOUS EDITION OF THIS FORM IS OBSOLETE.

Figure 111. Determining ballistic temperature.

BALLISTIC DENSITY FROM SURFACE DATA FM 6-15											
STATION			LOCATION			RE- LEASE TIME	DATE	HOUR	FLIGHT NR.		
<i>3d Div Arty</i>			<i>FORT SILL, OKLA</i>					LST <i>8 APR 60</i>	<i>1400</i>	<i>3</i>	
							GMT <i>8 APR 60</i>	<i>2000</i>			
1	(8) TYPE MESSAGE					(1) SURFACE PRESSURE	INCHES		MSL % STD (ICAO) <i>96.5</i>		
	BALLISTIC		S	XXXXXXXXXX			MILLIBARS		<i>978</i>		
2	(9) REGION							(2) DRY		<i>20.2 °C</i>	
	1	XXXX	3	4	5	6	7	(3) WET		<i>16.3 °C</i>	
3	(10) PERIOD							TEMPERATURE		(4) DEPRESSION	
	Night		XX	Afternoon		Transition				(5) VIRTUAL	
(11) TRUE SURFACE DENSITY						(6) STATION HEIGHT (10's METERS)					
(12) MEAN SURFACE DENSITY						<i>036</i>					
4	(13) DEPARTURE FROM MEAN SURFACE DENSITY					(7) SUNRISE		SUNSET			
						<i>0611</i>		<i>1901</i>			
Lines	DEPARTURE FROM MEAN BALLISTIC DENSITY (14)				BALLISTIC DENSITY % (15)			COMPUTATIONS			
1											
2											
3											
4											
5											
6											
7											
8											
9											
10											
11											
12											
13											
14											
15											
OBSERVER				COMPUTER				CHECKER			

DA FORM 6.50, 1 MAR 62

PREVIOUS EDITION OF THIS FORM IS OBSOLETE.

Figure 112. Data for selecting a table of departure from mean surface density.

b. *Recording Starting Data.* The data for selecting a table of departure from mean surface density are recorded on DA Form 6-50 (fig 112) in block (8), message type; block (9), region; and block (10), period.

c. *Type of Message.* An X is placed in the appropriate box in block (8), DA Form 6-50 to indicate the type of message being prepared.

d. *Region.* The Northern Hemisphere is divided into seven climatic regions (chart I, FM 6-16). The number of the region in which the met station is located is determined, and an X is placed in the appropriate box of block (9). If the met station is in the Southern Hemisphere, the number of the climatic region of the Northern Hemisphere most nearly resembling the climate of this location is used. Assistance in selecting this region may be obtained from the weather staff officer at division, corps, or army headquarters.

e. *Periods.* A meteorological day is divided into three periods—night, afternoon, and transition (fig 113). A separate set of data is provided for each period. If the sky is covered by opaque clouds, regardless of the time of day or night, the determination of densities by the departure method should be based on the transition period. In determining the correct period, the times of sunrise, sunset, and release are used in conjunction with chart IV, FM 6-16. An X is placed in the appropriate box in block (10), DA Form 6-50. The periods are defined as—

(1) *Night*—From 2 hours after sunset until 2 hours after sunrise.

(2) *Afternoon*—From 5 hours after sunrise until 1 hour before sunset.

(3) *Transition*—The two 3-hour periods between the night and afternoon periods.

164. Departure from Mean Surface Density

In order to determine the departure from mean surface density, the mean surface density in block (12) and the true surface density in block (11) must be known. The true surface density is determined to the nearest 0.1 percent by entering table Ib, FM 6-16, with the virtual temperature in block (5) to the nearest 0.1° Celsius and the surface pressure in block (1) to the nearest millibar and entered in block (11) (fig 114). The mean surface density is determined to the nearest 0.1 percent by entering chart V, FM 6-16 with the station altitude to nearest 10 meters and entered in block (12). The mean surface density is the ICAO standard density at the altitude of the

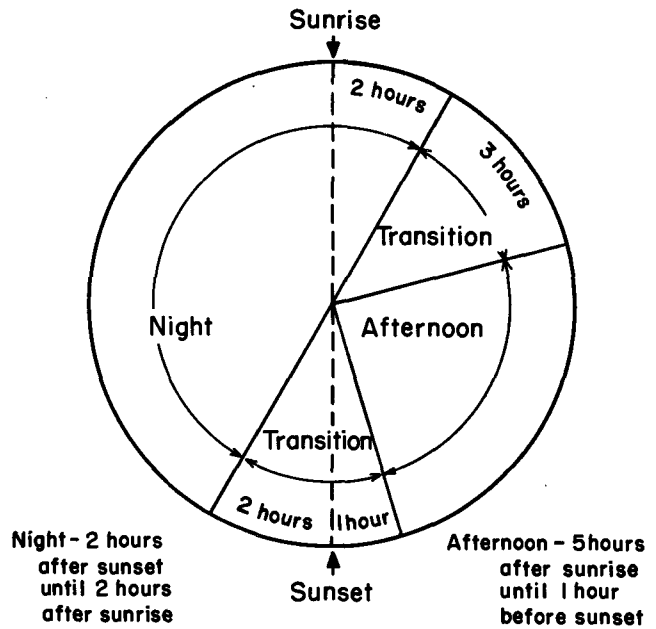

Figure 113. Meteorological day.

meteorological datum plane. The mean surface density in block (12) is algebraically subtracted from the true surface density in block (11), and the result to the nearest 0.1 percent is the departure from mean density. The departure from mean surface density, with the proper sign, is entered in block (13).

165. Ballistic Density

a. *Departure From Mean Ballistic Density.* The type of message, the region and the period are used to select the appropriate table of departure from mean surface density tables IIc and IIIc, FM 6-16. The table is entered with the line number and the value of the departure from mean surface density, with the proper sign, to the nearest whole percent. The departure from mean ballistic density is determined to the nearest 0.1 percent for each line number required and is entered on the appropriate line in block (14), DA Form 6-50.

b. *Percent of Standard Ballistic Density.* The percent of standard ballistic density for each line is obtained by adding algebraically the departure from mean ballistic density in block (12). The percent of standard ballistic density is entered to the nearest 0.1 percent for each line number in block (15) (fig 115).

c. *Encoding Ballistic Density.* The ballistic densities in block (15) are transferred to DA Form 6-57.

BALLISTIC DENSITY FROM SURFACE DATA FM 6-15											
STATION			LOCATION				RE-LEASE TIME	DATE	HOUR	FLIGHT NR.	
<i>3d Div Arty</i>			<i>FT. SILL, OKLA</i>						8 APR 60		1400
							GMT	8 APR 60	2000		
1	(8) TYPE MESSAGE					(1) SURFACE PRESSURE	INCHES		MSL % STD (ICAO) 96.5		
	BALLISTIC		S	<input checked="" type="checkbox"/>			MILLIBARS				978
2	(9) REGION							TEMPERATURE	(2) DRY		
	1	<input checked="" type="checkbox"/>		3	4	5	6		7	20.2 °C	
3	(10) PERIOD								(3) WET		
	Night		<input checked="" type="checkbox"/>		Afternoon		Transition		16.3 °C		
(11) TRUE SURFACE DENSITY						(5) VIRTUAL					
94.2						22.0 °C 102.4% STD					
(12) MEAN SURFACE DENSITY						(6) STATION HEIGHT (10 ³ s METERS)					
96.6						036					
4	(13) DEPARTURE FROM MEAN SURFACE DENSITY					(7) SUNRISE		SUNSET			
	-2.4					0611		1901			
Lines	DEPARTURE FROM MEAN BALLISTIC DENSITY (14)				BALLISTIC DENSITY % (15)			COMPUTATIONS			
1											
2											
3											
4											
5											
6											
7											
8											
9											
10											
11											
12											
13											
14											
15											
OBSERVER				COMPUTER				CHECKER			

DA FORM 6-50, 1 MAR 62

PREVIOUS EDITION OF THIS FORM IS OBSOLETE.

Figure 114. Determining departure from mean surface density.

BALLISTIC DENSITY FROM SURFACE DATA FM 6-15										
STATION <i>3d Div Arty</i>			LOCATION <i>FT. SILL, OKLA</i>			RE- LEASE TIME	DATE	HOUR	FLIGHT NR. <i>3</i>	
							LST	<i>8 APR 60</i>		
						GMT	<i>8 APR 60</i>	<i>2000</i>		
1	(8) TYPE MESSAGE					(1) SURFACE PRESSURE	INCHES		MSL % STD (ICAO) <i>96.5</i>	
	BALLISTIC		S		MILLIBARS <i>978</i>					
2	(9) REGION							(2) DRY		TEMPERATURE
	1	<input checked="" type="checkbox"/>	3	4	5	6	7	<i>20.2 °C</i>		
3	(10) PERIOD							(3) WET		TEMPERATURE
	Night		<input checked="" type="checkbox"/>		Afternoon		Transition		<i>16.3 °C</i>	
(11) TRUE SURFACE DENSITY						(5) VIRTUAL				
<i>94.2</i>						<i>22.0 °C 102.4 % STD</i>				
(12) MEAN SURFACE DENSITY						(6) STATION HEIGHT (10's METERS)				
<i>96.6</i>						<i>036</i>				
4	(13) DEPARTURE FROM MEAN SURFACE DENSITY					(7) SUNRISE		SUNSET		
	<i>-2.4</i>					<i>0611</i>		<i>1901</i>		
Lines	DEPARTURE FROM MEAN BALLISTIC DENSITY (14)				BALLISTIC DENSITY % (15)		COMPUTATIONS			
1	<i>-1.7</i>				<i>94.9</i>					
2	<i>-1.8</i>				<i>94.8</i>					
3	<i>-1.9</i>				<i>94.7</i>					
4	<i>-2.2</i>				<i>94.4</i>					
5	<i>-2.5</i>				<i>94.1</i>					
6	<i>-2.7</i>				<i>93.9</i>					
7										
8										
9										
10										
11										
12										
13										
14										
15										
OBSERVER					COMPUTER			CHECKER		
<i>Davis</i>					<i>Basham</i>			<i>Buntyn</i>		

DA FORM 6-50, 1 MAR 62

PREVIOUS EDITION OF THIS FORM IS OBSOLETE.

Figure 115. Completed ballistic density form.

CHAPTER 10

DETERMINATION OF NATO WINDS FROM OBSERVATION OF PILOT BALLOONS

166. Tracking Pilot Balloon and Recording Angular Data

a. General. The primary means to determine ballistic winds is by radiosonde observation. When electronic equipment fails or is not available, ballistic winds may be determined from observation of pilot balloons. Winds determined from pilot balloon observation are not as accurate as winds determined from radiosonde observation, basically because the height of a pilot balloon is estimated by using an assumed rate of rise. Pilot balloons and observing equipment are described in paragraphs 53 through 65.

b. Tracking. When possible, the balloon should be released approximately 100 meters downwind from the theodolite. This will reduce the tracking error and increase the accuracy of low-level winds. Initially, the balloon is tracked with the open sights and with the tracking controls disengaged. The first elevation and azimuth angles measured are read to the nearest whole degree. After reporting the first readings, the observer tracks the balloon through the telescopic sight. To change to the telescopic sight, the observer aligns the open sights on the balloon, then quickly moves to the eyepiece and engages the tracking controls. The wide-angle finder telescope may be used until the balloon steadies on its flight path. The balloon is tracked using the tracking controls for the remainder of the flight. When the timer-recorder commands WARNING, the observer adjusts the tracking controls so that the crosshairs are centered on the balloon. At the command READ, he ceases tracking and reports to the timer-recorder the elevation angle and the azimuth angle to the balloon, in that order, to the nearest 0.1°. Individual numbers are reported. An elevation angle of 71.6° and an azimuth angle of 247.3° are reported as SEVEN ONE POINT SIX. . TWO FOUR SEVEN POINT THREE. From time to time the observer must refocus the main telescope to insure a sharply defined image. When angular

values are changing rapidly, the observer may require assistance in positioning the sights on the balloon. An assistant may also be needed to read one or both angles while the observer concentrates on tracking. When the elevation angle approaches 90°, the balloon must be tracked by rapid azimuth movement of the telescope so that the elevation angle does not exceed 90°.

c. Recording Data. Angular data are recorded on DA Form 6-42 (Ballistic Winds from Observations of 30- and 100-Gram Balloons), which is also used to record the zone wind and ballistic wind values (fig 116). The timer-recorder completes the marginal information on the form. In column (1), time at top of zone, the time data which is not appropriate for the balloon being used should be lined through. At release, the previously zeroed timer must be started. A reading must be taken at exactly the times indicated in column (1). To do this, the timer-recorder commands WARNING to the observer approximately 5 seconds before the time indicated. At the exact time of reading, the timer-recorder commands READ. The observer reports the elevation and azimuth angles (*b* above). The timer-recorder examines the angular readings carefully and calls for a recheck of angles which appear unreasonable or inconsistent with those previously reported.

d. Interpolation of Missing Angular Data. If for some reason angular data for a given reading are missed, these data may be determined by time interpolation between the preceding and succeeding readings. This is done mathematically and is based on an assumed proportional change between the two readings. Not more than one set of angles may be missed for any one flight. If a set of angles is missed for more than one reading, the flight must be considered invalid and another release is necessary.

167. Plotting Zone Winds

a. General. After the elevation and azimuth angles to the position of the balloon at the top of

BALLISTIC WINDS FROM OBSERVATIONS OF 30 AND 100 GRAM BALLOONS (FM 6-15)													
STATION			LOCATION				RE-LEASE TIME		DATE		HOUR	FLIGHT NR.	
<i>3d Div Arty</i>			<i>FT. SILL, OKLA.</i>				LST		<i>8 APR 60</i>		<i>1400</i>	<i>2</i>	
		GMT		<i>8 APR 60</i>						<i>2000</i>			
Zone nr.	(1) Time at top of zone (min & sec)		(2) Elevation angle (degrees)	(3) Azimuth angle (degrees)	(4) Horizontal distance (meters)	(5) Horizontal travel in zone (meters)	(6) Time in zone (min & tenths)		ZONE WIND DATA		Line nr.	BALLISTIC WIND DATA	
	30 gram gallon	100 gram gallon					30 gram balloon	100 gram balloon	(7) Azimuth (10's mils)	(8) Speed (knots)		(9) Azimuth (100's mils)	(10) Speed (knots)
Off-set	/ / / / /			<i>360.0</i>	<i>100</i>	/ / / / /			<i>SUR 320</i>	<i>SUR 05</i>	<i>0</i>	<i>SUR 32</i>	<i>SUR 05</i>
<i>1</i>	<i>0:54</i>	<i>0:36</i>	<i>24.0</i>	<i>360.0</i>	<i>450</i>	<i>350</i>	<i>0.9</i>	<i>0.8</i>	<i>320</i>	<i>13</i>	<i>1</i>	<i>32</i>	<i>13</i>
<i>2</i>	<i>2:24</i>	<i>1:34</i>	<i>22.2</i>	<i>065.0</i>	<i>1220</i>	<i>1120</i>	<i>1.5</i>	<i>1.8</i>	<i>475</i>	<i>24</i>	<i>2</i>	<i>46</i>	<i>19</i>
<i>3</i>	<i>5:00</i>	<i>2:54</i>	<i>24.3</i>	<i>068.3</i>	<i>2210</i>	<i>1000</i>	<i>2.6</i>	<i>1.5</i>	<i>449</i>	<i>12</i>	<i>3</i>	<i>45</i>	<i>13</i>
<i>4</i>	<i>7:42</i>	<i>4:24</i>	<i>25.4</i>	<i>073.5</i>	<i>3160</i>	<i>980</i>	<i>2.7</i>	<i>1.8</i>	<i>471</i>	<i>12</i>	<i>4</i>	<i>46</i>	<i>13</i>
<i>5</i>	<i>10:24</i>	<i>5:48</i>					<i>2.7</i>	<i>1.4</i>			<i>5</i>		
<i>6</i>	<i>15:42</i>	<i>8:54</i>					<i>5.3</i>	<i>3.1</i>			<i>6</i>		
<i>7</i>	<i>21:00</i>	<i>12:00</i>					<i>5.3</i>	<i>3.1</i>			<i>7</i>		
<i>8</i>	<i>26:18</i>	<i>15:48</i>					<i>5.3</i>	<i>3.3</i>			<i>8</i>		
<i>9</i>	<i>31:36</i>	<i>18:48</i>					<i>5.3</i>	<i>3.5</i>			<i>9</i>		
<i>10</i>	<i>42:24</i>	<i>25:36</i>					<i>10.8</i>	<i>6.8</i>			<i>10</i>		
<i>11</i>	<i>53:12</i>	<i>36:24</i>					<i>10.8</i>	<i>6.8</i>			<i>11</i>		
<i>12</i>	<i>64:00</i>	<i>39:12</i>					<i>10.8</i>	<i>6.8</i>			<i>12</i>		
<i>13</i>	/ / / / /	<i>46:00</i>					/ / / / /	<i>6.8</i>			<i>13</i>		
<i>14</i>	/ / / / /	<i>52:48</i>					/ / / / /	<i>6.8</i>			<i>14</i>		
<i>15</i>	/ / / / /	<i>59:36</i>					/ / / / /	<i>6.8</i>			<i>15</i>		
(11) MESSAGE TYPE (CHECK ONE)			THEODOLITE OPERATOR		TIMER-RECORDER		ZONE WIND PLOTTER			BALLISTIC WIND PLOTTER			
<i>V S</i>			<i>Carlstrom</i>		<i>Schierer</i>		<i>Taylor</i>			<i>Trout</i>			

DA FORM 6-42, 1 MAR 62

PREVIOUS EDITION OF THIS FORM IS OBSOLETE.

Figure 116. Ballistic wind data.

each zone have been determined and recorded, the distance along the earth's surface to a point directly beneath the balloon is determined from horizontal distance table Ig, FM 6-16. The center of the plotting board represents the location of the theodolite (fig 22). Beginning with zone 1, the ground position of the balloon when it reaches the top of each zone is plotted from the origin.

b. *Offset Release Point Data and Plotting Procedure.* When the pilot balloon is released from a point offset more than 50 meters from the theodolite, the actual point of release in relation to the theodolite must be plotted on the zone wind plotting board. The direction to the release point is determined from the theodolite just before release, and the distance is determined by pacing from the point of release to the theodolite. The direction and distance of the release point must be included in the zone wind plot. Normal plotting

procedure is followed. The release point is marked "offset point," and the zone 1 point is marked as shown in figure 117.

c. *Determination of Distance Traveled.* Zone winds are computed from a projection of the balloon flight path on a curved earth. Thus, it is necessary to know the distance from the theodolite to the point on the ground directly under the balloon. Table Ig, FM 6-16, provides the distance traveled by the balloon for each standard height and is entered with the elevation angle to the balloon as an argument. The table is entered with the elevation angle to the nearest 0.1°. The distance is read to the nearest 10 meters. Distance to an offset release point need not be determined unless the release point is more than 50 meters from the theodolite (b above). These data are recorded in column (4), DA Form 6-42.

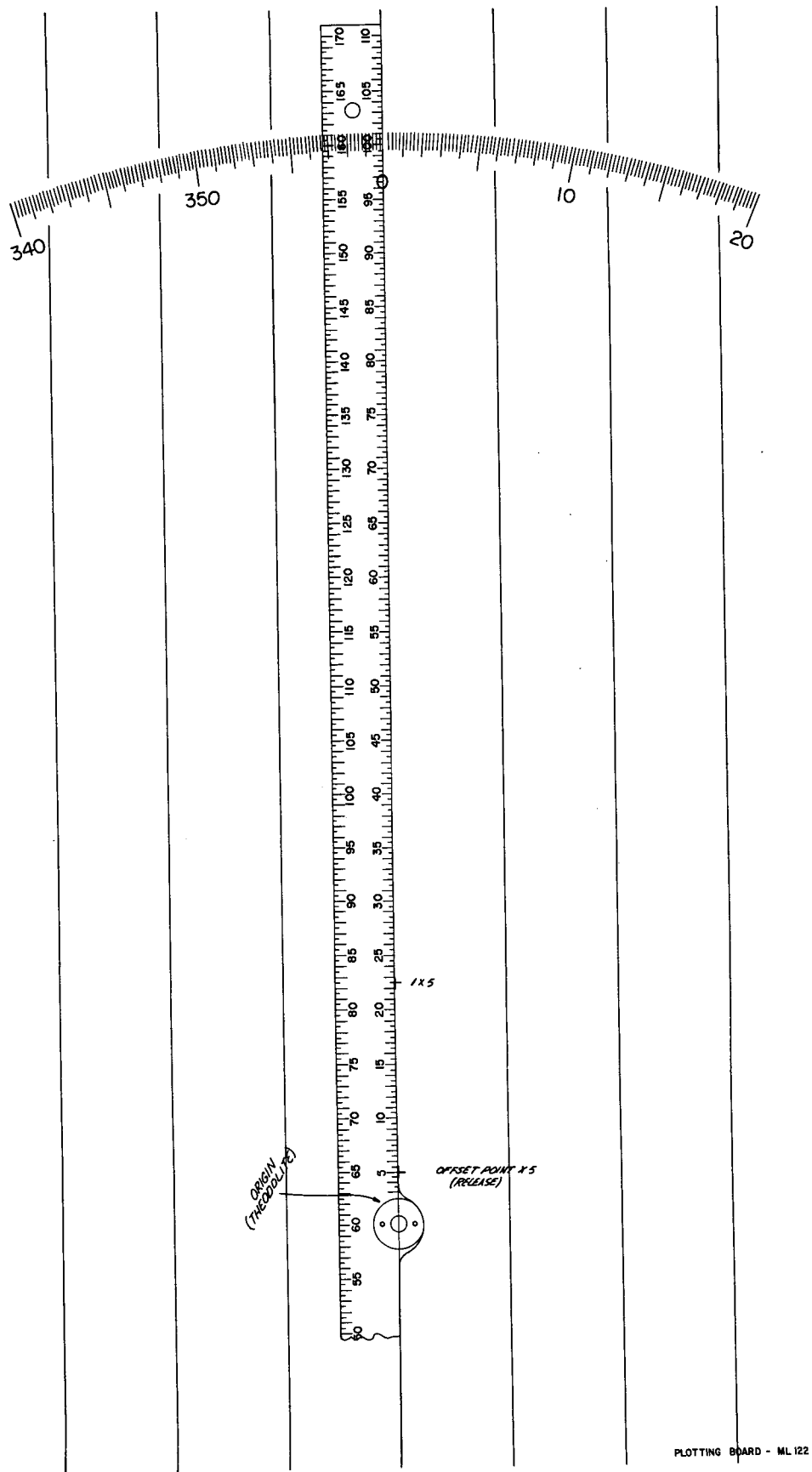

Figure 117. Zone wind plot.

d. *Plotting Scale.* Rule ML-126A permits plotting at a scale of 1 inch equals 750 meters. The longer scale is graduated every 50 meters and marked in hundreds of meters at 500-meter intervals. The shorter scale on the rule is graduated up to 11,000 meters and the longer scale is graduated up to 17,000 meters. At times it is necessary to expand or reduce the distance to be plotted. Multiplication factors of 2, 5, or 10 are used to magnify the distance to be plotted. When the distance to be plotted is less than 500 meters, it is necessary to expand the scale to a measurement of at least 500 meters to facilitate plotting. For example, if the distance is between 250 and 500 meters, a minimum factor of 2 is required so that the product is 500 or greater; if the distance is between 100 and 250 meters, a minimum factor of 5 is required; and, if the distance is less than 100 meters, a minimum factor of 10 is required. Normally, the largest of the factors 2, 5, or 10 that will permit plotting of at least two consecutive points is the best choice for expansion of the scale. When the distance is 500 meters or more, expansion is unnecessary. During the course of plotting, a point to be plotted may fall off the board. When this occurs, it will be necessary to reduce the plotting scale so that the point and subsequent points will fall on the plotting board, when reducing the scale, the same factors of 2, 5, or 10 may be used (preferably the smallest factor possible). To measure actual distance, the plotted distance must be divided or multiplied by the same factor used in plotting.

e. *Plotting Zone Winds.* Plotting begins as soon as the horizontal distance traveled in zone 1 has been determined. Plotting board ML-122 is oriented by placing north directly away from the plotter. Then the pivot hole of plotting rule ML-126A is placed on the pin in the center of the azimuth circle on the plotting board (fig 117). The pin can be raised by pushing forward on the lever beneath the board. The rule is then placed so that the edge in line with the pivot hole passes over the appropriate azimuth on the plotting board. Opposite the appropriate distances on the edge of the rule, the balloon position is marked with a small T-shaped index formed by a straight line (the top of the T) along the edge of the rule and a short tick mark (the stem of the T) perpendicular to the line. Each point plotted is identified by the zone number at which the angular data was read. If the plot is made at other than the normal scale, the factor by which the distance is expanded or reduced is shown after the zone number by writing a multiplication or division sign and the factor used (1 x 5) (fig 117). In this manner the angular

data for each of the required standard heights are plotted. A completed zone wind plot for a 30-gram pilot balloon would appear the same as the zone wind plot for a sounding balloon (fig 100).

168. Determining Zone Wind Speed and Direction

a. *Surface.* The direction and speed of the surface wind are determined with anemometer ML-433/PM. The azimuth is obtained by converting the reading of the compass direction to the nearest 100 mils (fig 118). The speed is read directly from the anemometer to the nearest whole knot. Surface wind direction and speed are recorded in columns (7) and (8) on DA Form 6-42. The procedure for using anemometer ML-433/PM is described in paragraph 49. An alternate means of measuring surface wind is observing the 30-gram pilot balloon for the first 15 seconds of flight, and the 100-gram balloon for the first 10 seconds of flight. The observed direction to the balloon is converted to a wind direction using table 1e, FM 6-16. The observed elevation angle is converted to a wind speed using table 1c or 1d, FM 6-16.

b. *Reading Zone Wind Direction.* The zone wind directions for zone 1 and higher zones are read directly from the plots by using wind plotting scale ML-577. A line is drawn from the point where the balloon entered the zone to a point over and sufficiently beyond the next point to enable the plotter

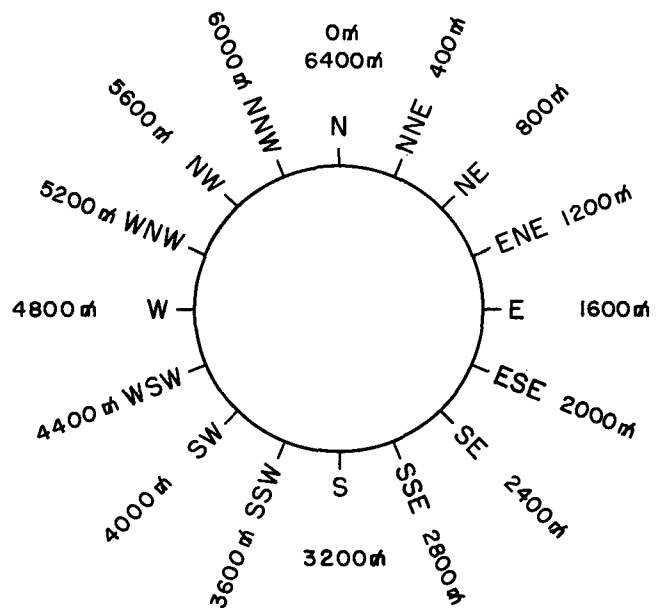
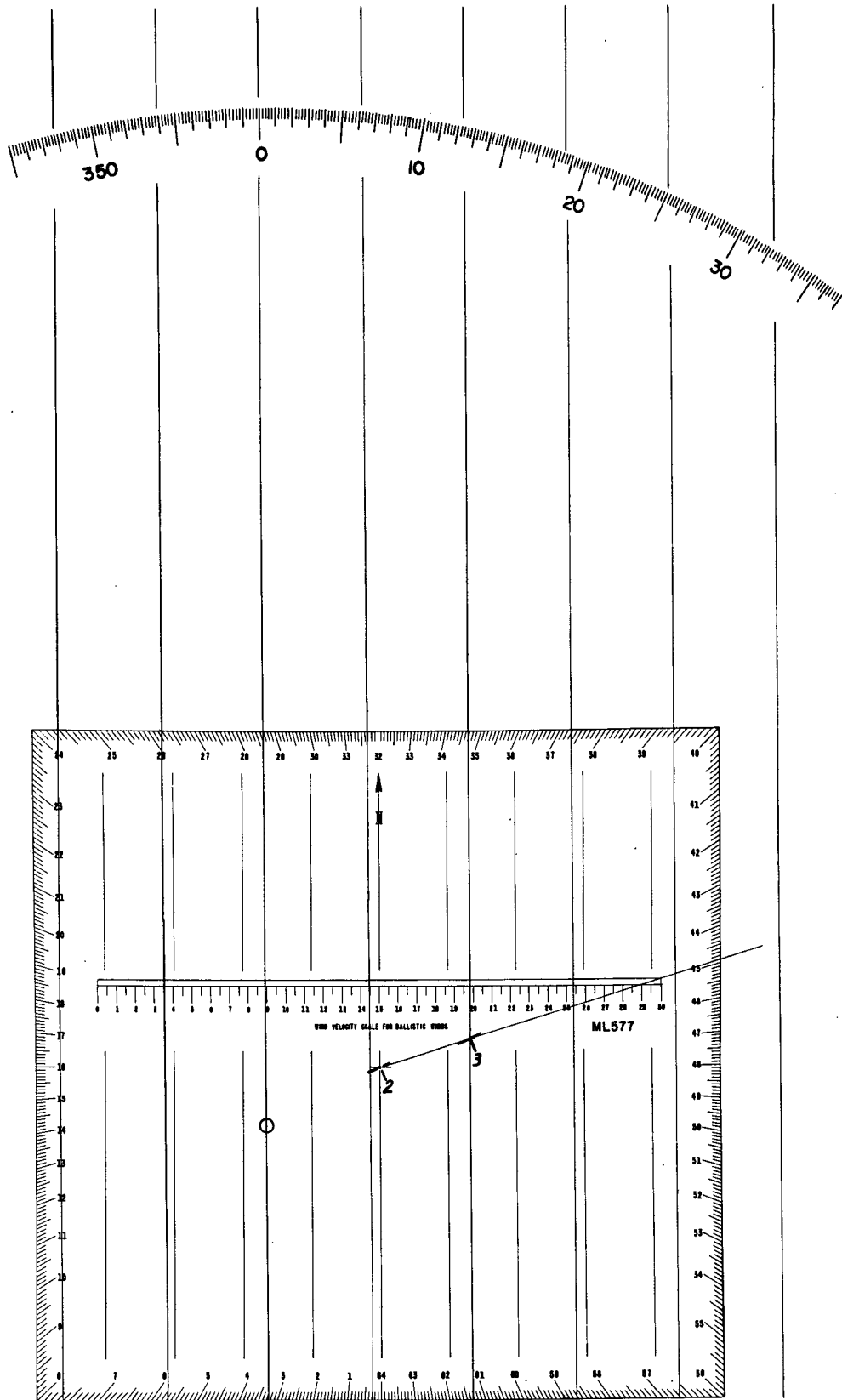

Figure 118. Conversion of points of compass to mils.



PLOTING BOARD-ML 122

Figure 119. Measuring zone wind direction with scale ML-577.

to read the direction on scale ML-577. The center of the scale, identified by the short horizontal line intersecting the long vertical north line, is placed over the point of origin or the plotted point where the balloon entered the zone being considered. The scale is oriented with north by aligning the vertical lines of the scale with those on the plotting board. The wind direction is read and recorded to the nearest 10 mils. This procedure is used for each succeeding plot. Since the wind direction is that direction from which the wind is blowing, back azimuths of the directions are measured. Scale ML-577 is constructed to allow the plotter to read these back azimuths directly. In figure 119, the zone wind direction for zone 3 is 4,490 mils. This azimuth is recorded as 449 in column (7), DA Form 6-42 (fig 116). When an offset release point is used, the wind direction for zone 1 must be determined from the offset release point because it is the point of origin and the wind direction or zone 1 is measured from the point of origin.

c. Determining Zone Wind Speeds.

(1) *Measuring distance traveled in zone.*

Horizontal travel in zone is the net distance in meters measured along the earth's surface that the balloon travels in a given zone. Since the amount of time in each zone is known, the zone wind speed is obtained by dividing the distance traveled by the time in zone and converting the result to knots. The time in each zone is always a fixed value predetermined by the assumed rate of rise of the balloon. These fixed time intervals are used in conjunction with distance traveled in zone to determine the wind speed. The distance traveled in each zone is measured in meters with rule ML-126A. For example, to measure the distance traveled in zone 2 (fig 120), the rule is aligned between the plotted points representing the tops of zone 1 and zone 2. The distance traveled (5,560 meters) is read to the nearest 10 meters (in fig 120, from 10 to 65.6 is equal to 5560 meters). The measuring procedure is repeated for each zone plotted. If the scale of the zone wind plot was expanded or reduced by a given factor, the distance traveled measured with the rule must be divided or multiplied by the same factor. In this example, $5,560 \div 5 = 1,112$ or 1110 meters. The values of distance traveled in zone are entered in column (5) on DA Form 6-42.

(2) *Time in zone.* Column (1) of DA Form 6-42 gives the time of arrival of the pilot balloon at each standard height. Since zone 1 begins at the surface (zero time), the time in zone 1 is equal to

the time the balloon reaches standard height 1. Time in zone 2 is equal to the time the balloon reached standard height 2 minus the time at standard height 1. Similarly, time in zone 3 is equal to the time the balloon reached standard height 3 minus the time at standard height 2. Time in zone for each succeeding zone is determined in the same manner. These values of time in zone are printed in column (6) of DA Form 6-42. Since the time at standard height for each artillery zone is a fixed time, the time the balloon spends in each respective zone is always the same.

(3) *Computing zone wind speed.* Each zone wind speed is computed by using the formula $D/T \times 0.0324 = S$, where D is the distance traveled in meters, T is the time in zone in minutes and tenths, and S is the zone wind speed in knots. The factor 0.0324 is used to convert meters per minute into knots. The values of zone wind speed obtained are recorded in column (8) on DA Form 6-42. The computations are performed with a slide rule as follows:

(a) The hairline on the indicator is set over the value of distance traveled on the D scale.

(b) The time in zone on the C scale is moved under the hairline.

(c) The hairline is moved to 0.0324 on the C scale.

(d) The zone wind speed is read under the hairline on the D scale to the nearest whole knot.

169. Determining Ballistic Winds

a. Ballistic winds for Line 0 and 1. Line 0 (SUR) and line 1 ballistic winds are the same as the surface wind and zone 1 wind. Therefore, the zone wind data recorded in columns (7) and (8) for lines 0 and 1 are entered for the ballistic wind data in columns (9) and (10) on DA Form 6-42.

b. Plotting Lines 2 through 15.

(1) *General.* A projectile with a trajectory that has a maximum ordinate in excess of 500 meters (second standard height) is affected by the wind in both zones 1 and 2; a projectile that rises to 1,000 meters (third standard height) is affected by winds in zones 1, 2, and 3, and a projectile that rises to 3,000 meters (sixth standard height) is affected by winds in zones 1, 2, 3, 4, 5, and 6. In general, the value of a ballistic wind for any given line of the met message is arrived at by considering the zone winds of all zones from the surface to the standard height of that line. The ballistic wind for any line above line 1 is determined by making a plot of the weighted wind effect of each of the zones which contributes to the ballistic value to

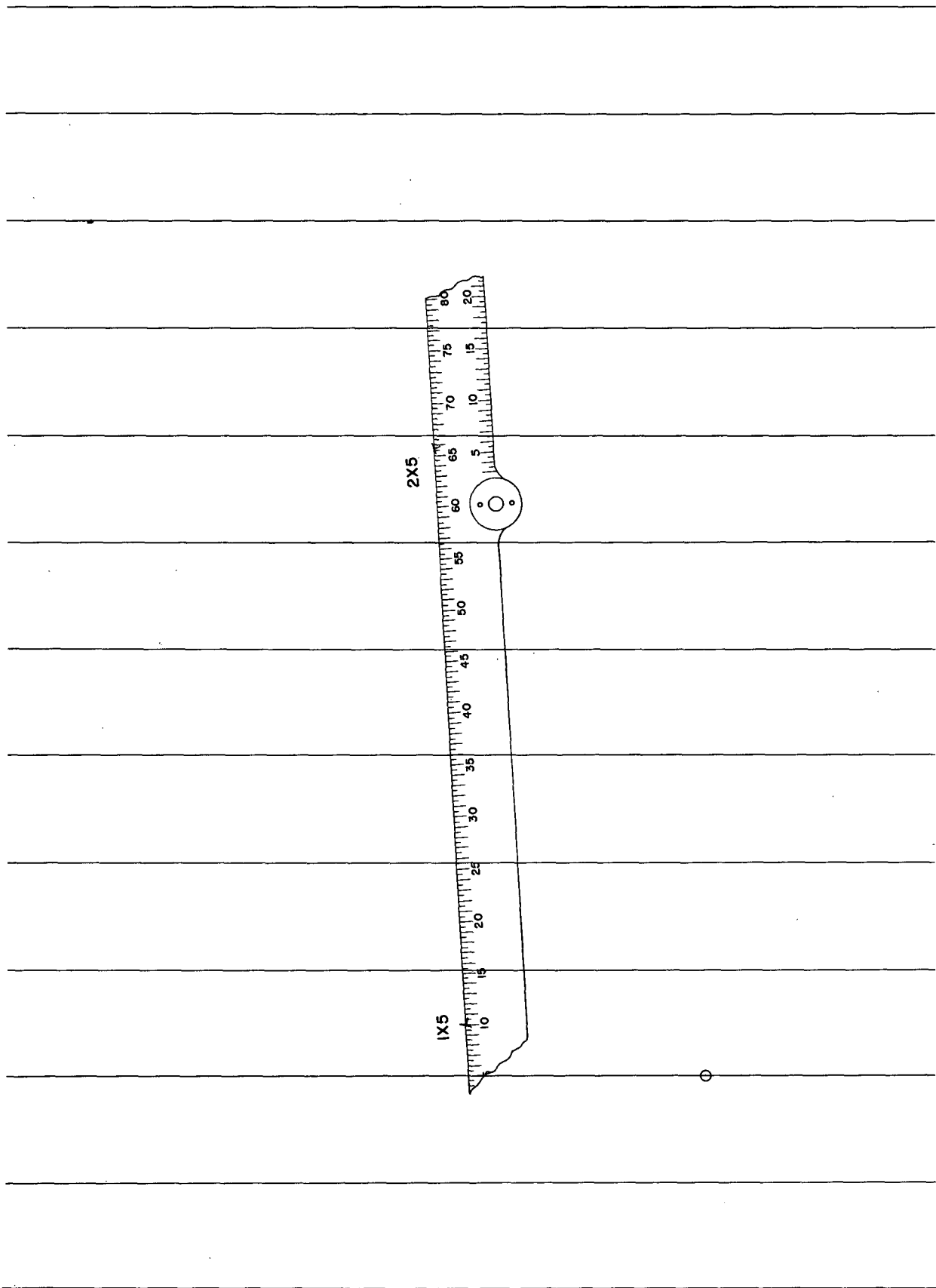

Figure 120. Measuring distance traveled in zone.

be listed in that line of the message. These plots take the form of vectors. The vector direction represents zone wind direction, and the magnitude of the vector represents the weighted zone wind speed. The sum of the zone wind vectors is the ballistic wind.

(2) *Selecting starting points.* The plotting board ML-122 is oriented so that the closely spaced parallel lines run from the top to the bottom of the board. The top of the board represents north. Points of origin for the lines to be plotted are selected at the intersections of the horizontal and vertical lines. The proper selection of these points of origin will depend on the direction and speed of the winds aloft and should afford maximum plotting space. The first origin selected is that for line 2. It is usually selected on the horizontal line that affords maximum plotting space in the direction that the plot is expected to extend. Its position along the line depends on the direction of the wind. If the wind is from the west, the origin is selected at one of the intersections near the left edge of the board. If the wind is from the east, the origin is moved farther to the right so that subsequent plots will not fall off the board. The remaining origins are placed along the same line as the first until they fall too close to the edge of the board, then another line is used. Each origin is numbered to represent the line being plotted. Therefore, it is possible to have origins numbered from 2 to 15.

(3) *Plotting zone 1 direction.* The center of scale ML-577 is centered over the origins for lines 2 through 15, and oriented so that the north-south lines of the scale are aligned with the north-south lines on the board. Since the projectile must pass through zone 1 in order to reach the higher zones, the wind direction for zone 1 is first plotted at each of the origins. The direction for zone 1 is plotted by selecting the azimuth along the outer edge of the scale which corresponds to the wind direction for zone 1 (3,200 mils in fig 116). The point of intersection is identified by a small T-shaped index formed by drawing a straight line (the top of the T) along the edge of the scale and a short-tick mark (the stem of the T) perpendicular to the line (fig 121).

(4) *Determining zone 1 weighted wind speed.* The weighted wind speed tables in FM 6-16 are used to determine the weighted wind speed. The selection of the correct table depends on the type of message. In figure 116, a type-3 message is checked. This means that the weighted wind speed table for a type-3 message (table IIIc) is used. The arguments for entering the table are the

zone number, the zone wind speed and the line-zone number. The numbers across the top of the table are the line-zone numbers. In table IIIc, Weighted Wind Speeds (type-3 message), Zone 1, the first line-zone number is 21. This is interpreted as meaning line 2, zone 1 (i.e., the effect of zone 1 on line 2). The next line-zone number is 31 (line 3, zone 1). The wind speed to the nearest knot for zone 1 is used to enter the table. In figure 116, the zone 1 wind speed is 13 knots. By entering the table and interpolating for 13 knots the weighted wind speed for line 2, zone 1 is found to be 2.6 knots; for line 3, zone 1, the weighted wind speed is 1.2 knots; and for line 4, zone 1, the weighted wind speed is 0.8 knots.

(5) *Plotting zone 1 weighted wind speeds.* In order to plot the first weighted value, the ballistic wind velocity scale on scale ML-577 is oriented so that the zero falls at the origin of the plot and the edge indicating wind speeds extends through the point of intersection of the stem and top of the T-shaped index, or azimuth mark (fig 122). The weighted wind speed is plotted to the nearest 0.1 knot by interpolating between the printed graduations when necessary. The weighted wind speed determined from the table for zone 1 for line-zone 21 is 2.6-knots. With the zero end of the scale at the point of origin for line 2 and the scale oriented through the azimuth mark, a straight line is drawn from the origin to the 2.6-knot graduation on the scale, where the small tick mark is made perpendicular to the scale. For identification, the plot is numbered 21. In order to indicate that this particular segment of the plot has been completed, a small "x" is drawn through the azimuth mark at the time the weighted speed is plotted. The scale is shifted to the next origin which is 3. The same procedure is used to plot the weighted wind speed of 1.2 knots for line-zone 31. The plot is drawn and identified with a 31, and a small "x" is placed through the azimuth mark. Next, the weighted wind speed is plotted from origin 4 and identified as 41, etc.

(6) *Plotting zone 2 weighted wind speeds.* The same procedure that was used to plot the zone 1 wind direction is used to plot the zone 2 wind direction except that the center of scale ML-577 is aligned over the last plot (21, 31, 41, etc). The zone 2 wind direction of 4,740 mils is plotted, and a T-shaped azimuth mark is drawn to indicate direction. The zone 2 weighted wind speed is determined by entering table IIIe for zone 2 with the zone wind speed and the line zone number. In figure 116, the zone 2 wind speed is 24 knots. To obtain the weighted wind speed for line 2, zone 2, the table is entered under the line-zone

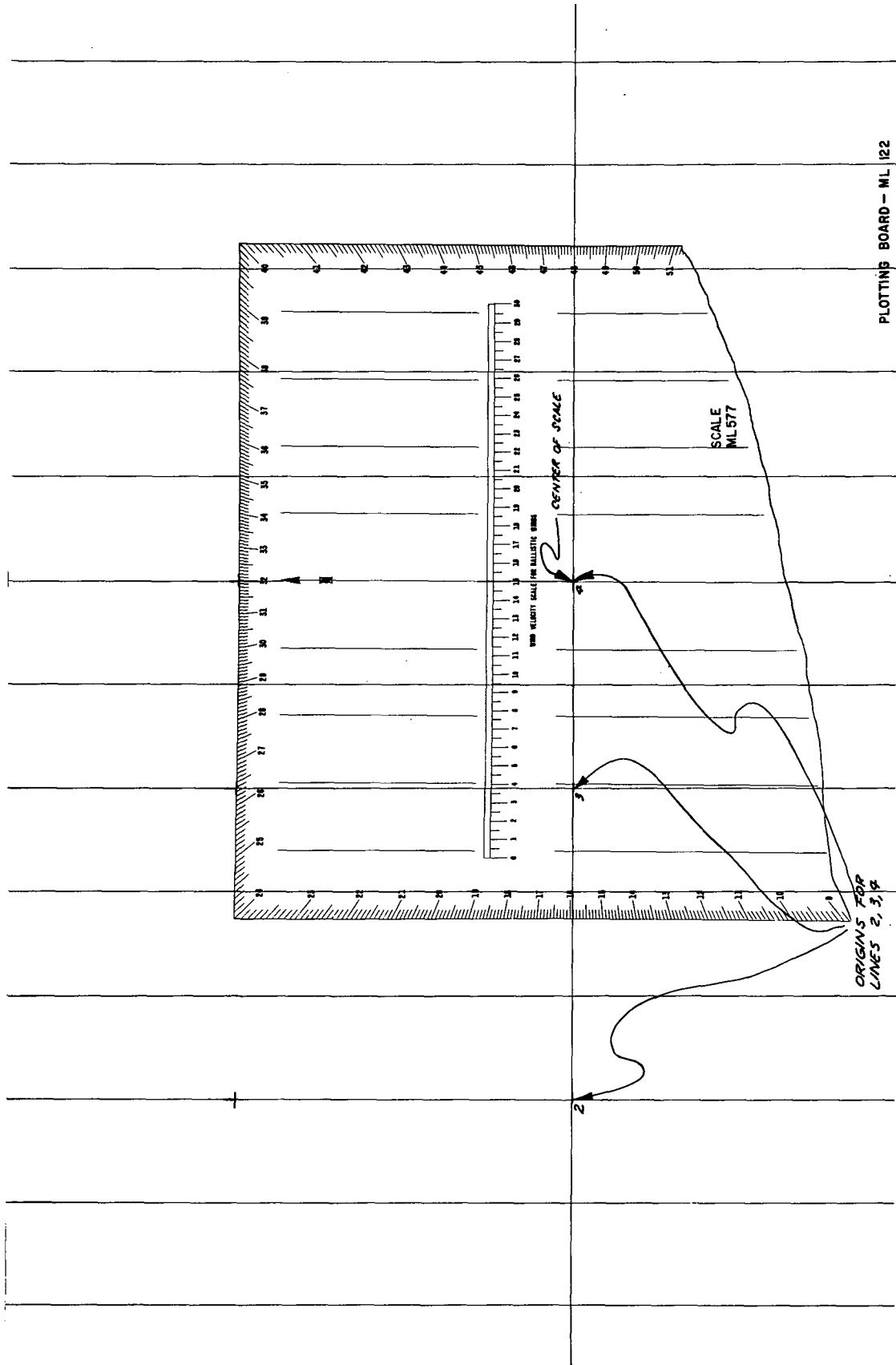

Figure 121. Ballistic wind plot.

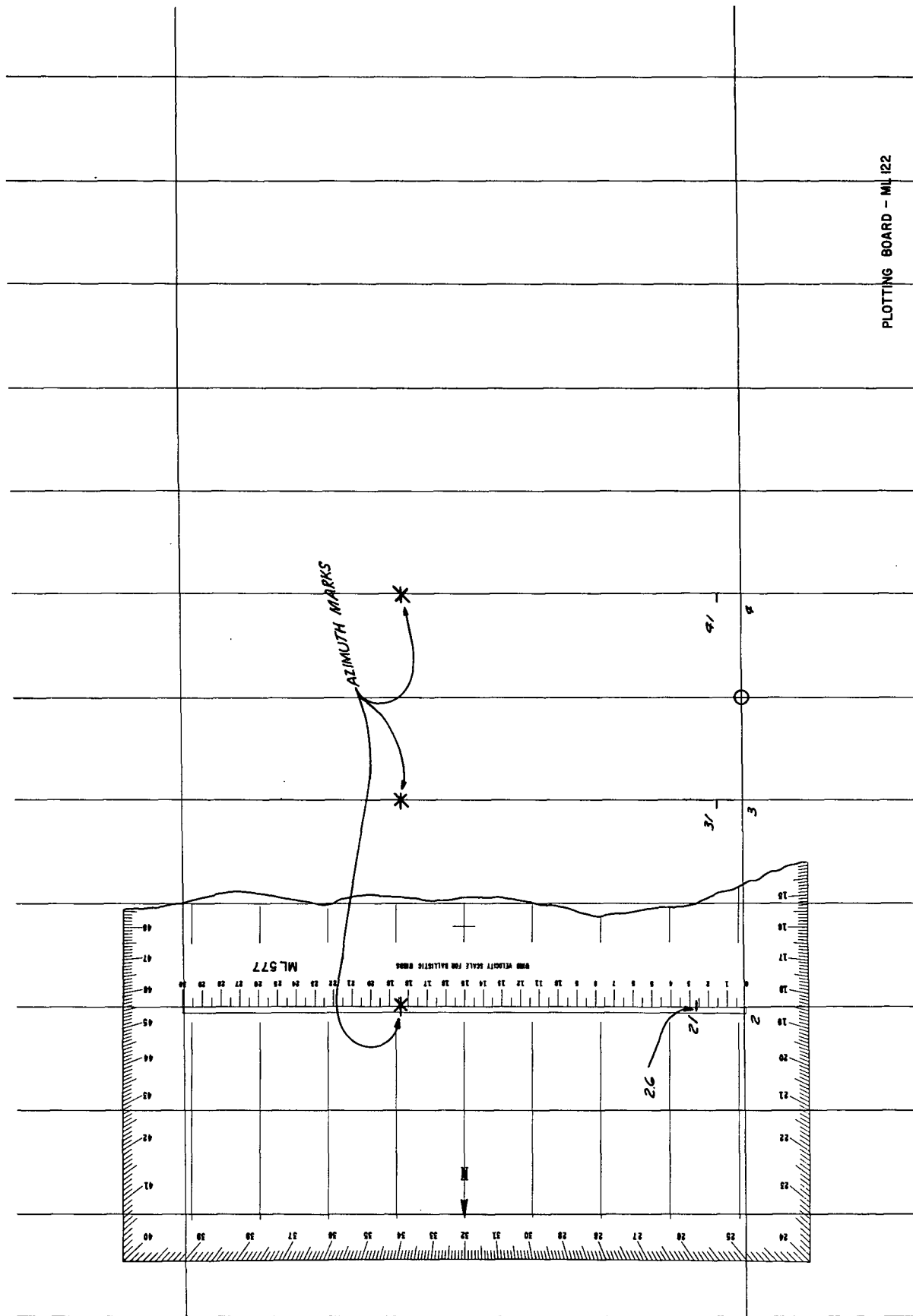
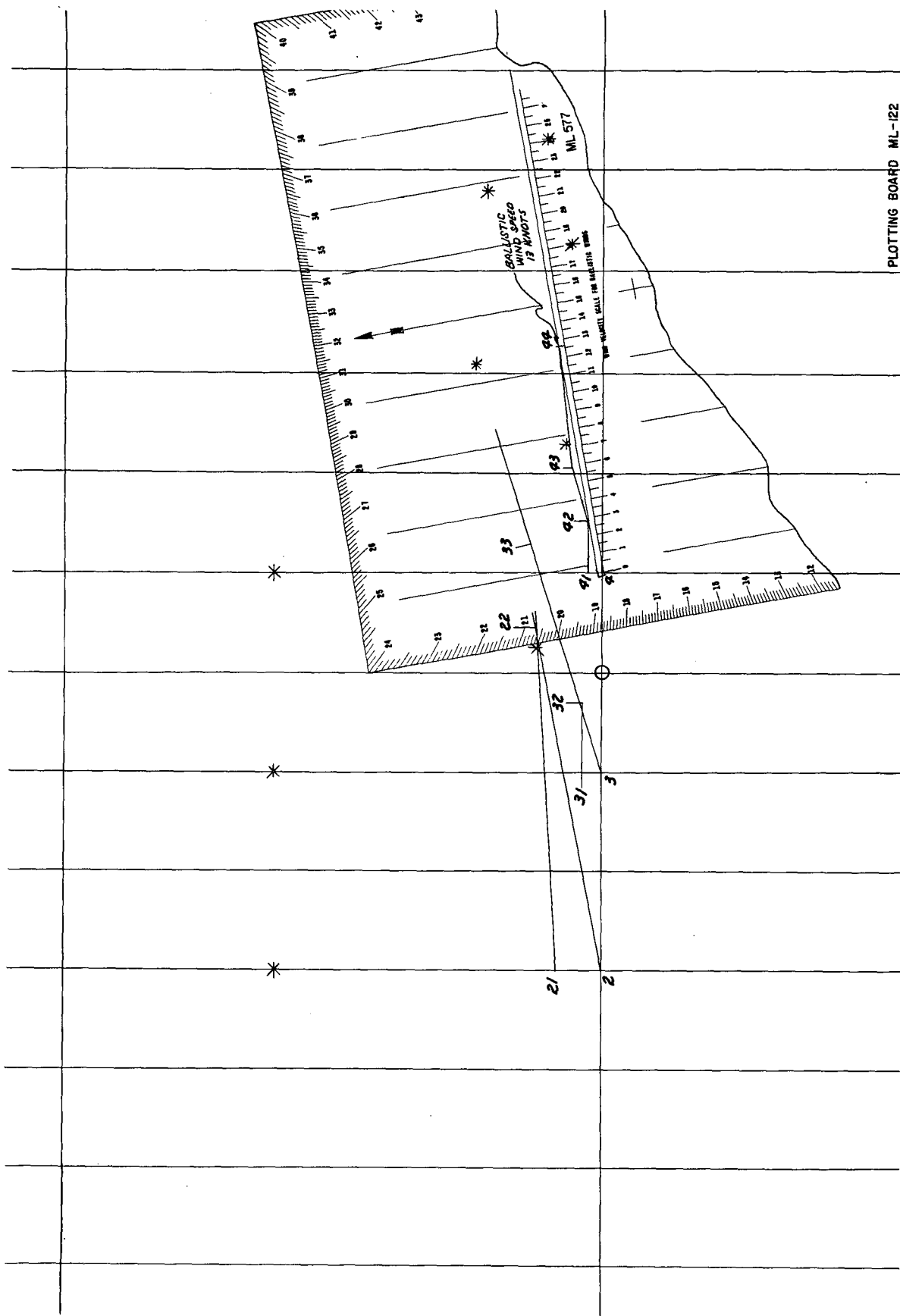

Figure 122. Plotting weighted wind speeds.



PLOTTING BOARD ML-122

Figure 123. Measuring ballistic wind speed.

number 22 at the wind speed of 24 knots. This weighted value is 19.2 knots. For plot 32, the weighted value is 4.6 knots; for plot 42, the weighted value is 2.9 knots. The weighted wind speeds are determined and plotted for the remaining lines by placing the zero mark of the ballistic wind velocity scale at the end of the first segment (21, 31, 41, etc) instead of at the origin. An "x" is placed through the azimuth mark as before to indicate completion of the plot.

(7) *Completing the ballistic wind plot.* After the zone 2 weighted wind speeds have been plotted, the effects of the zone 3 wind speed on line 3 and on lines above line 3 are plotted. The zone 3 wind direction is plotted in the same manner as the zone 2 wind direction, except that the center of the scale is oriented over the end of the segment for each line (32, 42, 52, etc.). Then the zone 3 weighted wind speeds are scaled off along the zone wind direction for each of the lines. Similarly, the wind directions and weighted wind speeds for succeeding zones are plotted for the lines they affect. Each plot for a given line originates from the last point plotted for that line. In this way the weighted wind effects for each zone are combined as vectors to obtain the total effect (fig 123). When the line and zone number for the plot for any given line coincide and before plotting is continued, the plot for this line is closed out and the ballistic wind direction and speed are

measured and recorded in columns (9) and (10) on DA Form 6-42. The ballistic wind speed is measured first by placing the zero of the wind velocity scale on the point of origin and reading the ballistic wind speed at the end of the last plot for that line (fig 123). The speed is read to the nearest 0.1 knot and rounded off to the nearest whole knot. The ballistic wind direction is determined last by extending a line from the point of origin through the last plot. The line must be of sufficient length so that it will extend beyond the outer edge of scale ML-577. The midpoint of the scale is placed over the point of origin with the north-south lines on the scale parallel to the north-south lines on the plotting board. The direction is read at the point where the extended line passes underneath the outer edge of the azimuth scale. This azimuth is read to the nearest 10 mils and recorded to the nearest 100 mils.

(8) *Plotting off the board.* When a point extends off the plotting board, the entire plot is moved by changing the origin. The direction and speed of the last point plotted are read from the origin and replotted from the new origin; it is not necessary to replot intermediate points between the origin and the last point.

(9) *Encoding data.* Ballistic winds, columns (9) and (10), DA Form 6-42, are encoded on DA Form 6-57 (NATO Met Message) as described in paragraph 154.

CHAPTER 11

VALIDITY OF ARTILLERY METEOROLOGICAL MESSAGES

170. General

The validity of the meteorological message is extremely important to artillery commanders and staff officers. There are two broad factors which affect the validity of met message data—the accuracy of the weather-measuring system and the variability of the atmosphere. Artillery met sections are capable of obtaining very accurate measurements of the atmosphere through which the radiosonde travels; however, in the true sense, these measurements pertain only to one location and one instant in time. The values of wind, air density, and air temperature continuously undergo complex and inconsistent variations in both time and space (distance). On occasion these weather variables may change abruptly over a very short distance or over a brief interval of time. On other occasions and in other geographical areas, the change may be extremely gradual with respect to both distance and time. The trajectory of the artillery projectile will always be some distance from where the weather elements were actually measured. Also, some time will elapse between the measurement of atmospheric conditions and the firing of the weapon. Time is required for completion of the radiosonde flight, computation and transmission of the message, and the determination of appropriate meteorological corrections to be applied to the weapon. Thus, the validity question arises.

171. Space Validity

a. In general, the validity of a message decreases as the distance increases from the meteorological sounding site. Local topography has a pronounced effect on the distance to which met data may be reasonably extended. For instance, mountainous terrain particularly influences the wind, causing large variations over short distances. This orographic effect on wind frequently extends to heights must greater than the tops of the mountains. It would be impossible to compute a valid distance for every combination of weather and terrain which might exist; however, the following general rules may be used as a guide:

(1) Over fairly level terrain, such as the Central States, a message is considered valid up to 32 kilometers.

(2) In mountainous terrain the valid distance should be reduced by approximately 50 percent.

b. The proximity of large bodies of water have an effect on both the time and space validity of met messages due to the existence of land and sea breezes and the effect of humidity on density (increased humidity decreases air density). Therefore, the space validity of a message should be reduced when the met station is operating along coastlines.

172. Time Validity

Because of the changing nature of weather data, the validity of a message will decrease with the passage of time. With the present equipment, it is extremely difficult for the artillery met section to provide ballistic met messages more frequently than every 2 hours. Experience has shown that meteorological messages provided more often than once every 2 hours give only marginal improvement to artillery fire. There are no specific rules by which the valid time may be specified. The valid time is a function of the characteristics of the atmosphere. When the weather pattern is variable, the valid time should not exceed a 2-hour period. If the passage of a weather front is forecast for the area, the valid time of the message should not extend beyond the time forecast for the arrival of the front in the area. When the weather pattern is stable, the valid time may be extended to 4 hours during the middle of the day or night.

173. Validity of Density Departure Tables

The ballistic density departure tables in FM 6-16 are used when the pilot balloon and surface observation technique of obtaining atmospheric data are employed. The tables are based on climatological data; therefore, it is apparent that upper air density values obtained from these climatological data are not as accurate as density

values based on actual upper air measurements with a radiosonde.

174. Criterion for Selection of Meteorological Data

a. In November 1959, the U.S. Army Signal Research and Development Laboratory, Fort Monmouth, New Jersey, published the results of a study on the validity of ballistic density obtained from various sources. This study was based on a series of firings conducted in 1958 at Fort Sill, Oklahoma. From that study, it was determined that the order of accuracy of the various sources is as follows:

(1) Current met message from local observation station.

(2) Current met message from any station within 32 kilometers of the local station.

(3) A 2-hour old met message from local station.

(4) Current met message from any station within 32 to 80 kilometers of the local station or a 2-hour old message from a station within a 32-kilometer radius.

(5) Current met message from a station 80 to 112 kilometers distant, or a 2-hour old message 32 to 48 kilometers distant, or a 4-hour old message from local station.

(6) Ballistic density departure tables.

b. The list of sources in *a* above indicates that more accurate ballistic density values can be obtained by using met messages from other areas or older messages from the local observation station than by using the density departure tables. Ballistic density departure tables should be available, but they should be used only as a last resort when no better data are available.

PART THREE

METEOROLOGY FOR SOUND RANGING

CHAPTER 12

PRINCIPLES OF SOUND RANGING

175. Sound Ranging Theory

a. Sound ranging is a method of locating a sound source, such as the firing of a weapon or the burst of a projectile, through computations which depend on the speed of the sound wave produced. The discharge of a gun or the burst of a shell causes a sound disturbance or pressure vibration in the air which lasts for only a fraction of a second. The sound wave travels outward through the air at speeds which vary with the atmospheric conditions. Sound ranging techniques locate the source of the sound wave by measuring the time intervals between the arrival of the sound wave at several accurately located microphones.

b. The speed of sound is not a fixed value but varies with existing meteorological conditions. In order to make the necessary computations, certain atmospheric conditions are designated as standard. Existing atmospheric conditions are measured, plotted, and weighted, and this information is disseminated to the sound ranging sections of the target acquisition battalions. Correction factors are applied to the measured sound ranging data to compensate for the variation of actual atmospheric conditions from standard.

c. The standard meteorological conditions on which all computations are based are a wind speed of zero and an effective temperature of 10° Celsius at a height of 200 meters above the surface. Under these standard conditions, the speed of sound is 337.6 meters per second. Standard conditions seldom, if ever, exist in the atmosphere.

176. Meteorological Effects on the Speed of Sound

The direction and speed of the wind and the temperature and humidity of the air affect the manner in which a sound wave travels through the atmosphere

a. Wind. Wind may increase or decrease the speed of sound, depending on whether the wind moves with or against the direction of the sound waves. Cross winds tend to displace the entire sound wave without distorting it, provided the entire volume of air moves at the same speed and in the same direction. In the atmosphere, the wind speeds are seldom uniform and tend to distort the sound waves. However, wind corrections are based on the assumption that the wind velocity is uniform. As an example of the effect of wind on locating a sound source, it is known that a cross wind of 9 knots at standard effective temperature (10° C.) and at a range of 9,144 meters results in a location which is 128 meters right or left of the true location. In addition to introducing errors in the location of sound sources, high winds create noise interference on the sound recording which makes evaluation extremely difficult. Sound ranging is ineffective when surface wind speeds exceed 45 knots.

b. Temperature. One formula for expressing the speed of sound is $V = 20.06 \sqrt{T_s}$, where V is the speed of sound in meters per second and T_s is the effective or sonic temperature in degrees Kelvin (sonic temperature in degrees Celsius plus 273.2). Hence, it may be stated that the speed of sound varies directly with the temperature. For example, a sound source located at a range of 7,315 meters, a sonic temperature of 21° C. (11° C. above standard) at a height of 200 meters above the surface, and a calm atmosphere (no wind) will result in erroneously locating the source 155 meters over the true location.

c. Relative Humidity. The speed of sound also varies directly with the amount of moisture in the air. This effect is compensated for by adjusting the air temperature. Sonic temperature is air temperature adjusted for moisture. The adjustment is described in paragraph 179.

d. Pressure and Density. Another formula for expressing the speed of sound is $V^2 = \frac{10^6 KP}{\rho}$, where V is the speed of sound in meters per second, K is a constant which is the ratio of specific heat at constant pressure to the specific heat at constant volume of the gas (for air, K = 1.4), P is the pressure in millibars, and ρ is the density in grams per cubic meter of the gas. From this equation it can be seen that the speed of sound is a function of the ratio of pressure to density. Since pressure and density change in almost the same proportion in the atmosphere, the ratio remains fairly constant. Therefore, changes in pressure and density have slight effect on the speed of sound and are disregarded.

177. Meteorological Data for Sound Ranging

The meteorological data which are used for sound ranging consist of the sonic temperature in degrees Celsius at a height of 200 meters above the met station and the effective wind direction and speed between the surface and a height of 800 meters. The effective wind direction is expressed to the nearest 10 mils. Effective wind speed is a weighted average of the wind speed in knots between the surface and a height of 800 meters.

a. Source of Data. Sound ranging data are available at the artillery met stations and the sound ranging sections.

(1) Artillery met sections use radiosondes to accurately measure wind and temperature.

(2) Sound ranging sections observe pilot balloons to measure the winds. They measure temperature at the surface and estimate the sonic temperature at 200 meters.

b. Data for the Sound Ranging Met Message.

(1) *Steps in determination of data.*

(a) The sounding ranging effective temperature, or sonic temperature, is determined from measurements of temperatures and relative humidity.

(b) The sound ranging effective wind direction and speed are determined from angular measurements to the position of a balloon at timed intervals. The wind directions and speeds computed from these measurements for certain layers of the atmosphere above the met station are weighted, and these weighted values are to-

taled to obtain the effective wind direction and speed.

(2) *Wind weighting factors.* Four sets of wind weighting factors are available for computing the effective wind. The correct set is chosen by comparison of the measured layer wind speeds.

(3) *Recording data.* Final data are recorded on DA Form 6-48 (Weather Data for Sound Ranging), and are reported to the sound ranging sections. The form provides spaces for recording the measurements, applying weighting factors, and recording the final data.

c. Transmission of Data. The sound ranging data are transmitted to the sound ranging section by the most expeditious means. The best means of transmission will depend on the relative location of the met section furnishing the data. If the data are prepared by an electronic met section, away from the sound base, wire communication will normally be used.

d. Coordination Between Sound Ranging Officer and Meteorological Officer. Close liaison between the sound ranging and met sections is very important to insure that the meteorological data used to compute the sound ranging data are the best available. Usually the sound ranging section prepares its own data by using its visual equipment. However, it should be kept in mind that the met section using electronic equipment is capable of providing these data. Also, the sound ranging section will not be able to use visual equipment during periods of poor visibility, and electronic data may be the only data available. The decision on whether to use electronic data or the sound ranging section data will depend on the location of the met section in relation to the sound base and the topography of the area. Many times the met section can report to the sound ranging section the presence of abnormal temperature lapse rates off surface that will affect the evaluation of sound ranging effective temperature. Technical advice on methods of computing meteorological data and on maintenance of equipment common to both sections is available at the met section. Therefore, the sound ranging officer should contact the nearest met section in his area and make the presence of the sound ranging section and its requirements known.

CHAPTER 13

SOUND RANGING MESSAGE DEVELOPED FROM RADIOSONDE DATA

178. General

It is possible to determine the effective wind and temperature from the data obtained during any radiosonde sounding. A radiosonde is carried aloft by a sounding balloon and transmits meteorological data to a radiosonde recorder on the ground. The radio direction finder automatically tracks the radiosonde and records angular data used for determination of wind direction and speed. A sound ranging message can be prepared from the recorded data, and preparation of the sound ranging message will not appreciably delay the preparation of the ballistic met message. The sound ranging message is forwarded to the sound ranging sections immediately upon completion of the necessary computations; it is not held until the flight is completed.

a. Modifications to Weather Data for Sound Ranging Form. When a sound ranging message is to be prepared from radiosonde data, DA Form 6-48 (Weather Data for Sound Ranging) (fig 124) is used. In the WIND DATA block on the form the column of 30-gram balloon data under the heading TIME AT LAYER LIMIT is lined out. The SURFACE OBSERVATION section in the TEMPERATURE DATA block is not used, and the TIME OF SUNRISE and TIME OF SUNSET blocks are not required.

b. Consideration in Selecting the Observation Site. The location of the artillery met section normally is dictated by the location of the artillery units using its data. The met section may or may not be centrally located either laterally or in altitude with respect to the sound base. However, its location relative to the sound base should be kept in mind so that the meteorological data provided the sound ranging unit will be valid.

179. Procedure for Determining Effective Temperature

The effective temperature is the sonic temperature at a height of 200 meters. The sonic temperature is computed from the formula $T_s = \frac{3T_v + T}{4}$, where T_s is the sonic temperature, T_v is the vir-

tual temperature, and T is the thermistor temperature. The sonic temperature is computed in the RADIOSONDE OBSERVATION section in the TEMPERATURE DATA block on DA Form 6-48 (fig 124). The virtual temperature is read to the nearest 0.1° from the sounding curve on chart ML-574/UM at the point where it crosses the 200-meter zone height line and recorded on the data sheet. The thermistor temperature value at 200 meters is determined by plotting the thermistor temperature at the significant level just below and just above the 200-meter line (1 and 2, fig 125). A straight line is drawn between the two plots. The point at which this line crosses the 200-meter line (3, fig 125) represents the thermistor temperature at 200-meters. The thermistor temperature to the nearest 0.1° C. is entered in the RADIOSONDE OBSERVATION section in the TEMPERATURE DATA block on DA Form 6-48. The sonic temperature is then computed and entered on the line for effective temperature in the DATA REPORTED TO SOUND RANGING SECTION block. The data in figure 125 normally will be reflected on chart ML-574/UM (fig 89) which is used for the ballistic sounding; however, for instructional purposes the data are shown separately.

180. Procedure for Determining Effective Wind Direction and Speed

The sound ranging layer wind data are obtained from radiosonde data in the same manner as the artillery zone winds are obtained (para 147). First, the pressure that the sounding balloon encountered at each sound ranging layer limit is read from chart ML-574/UM (fig 125), and recorded on the sound ranging form, DA Form 6-48. The times at which the radiosonde transmitted these pressures are determined from the pressure-time chart (fig 97) and entered on the sound ranging form. The azimuth and elevation angles corresponding to these times are read from the control-recorder tape and entered on the form. From these angular values and the times, the layer winds are determined by the wind plotting technique described in *d* below. For sound

ranging, the effective wind speeds and directions are obtained from the sound ranging layer winds in the manner described in e below.

a. *Determining Time at Layer Limits.* The pressures at the sound ranging layer limits of 200, 400, 600, and 800 meters are determined from the sounding curve on chart ML-574/UM (fig 125). The time at each layer limit is determined by entering the pressure-time chart (fig 97) at the pressure value of the layer limit on the left side of the chart, moving horizontally to the right until the pressure-time curve is intersected, and reading the time on the time scale, vertically beneath this point. The time for each layer limit is read to the nearest 0.1 minute and is entered in the WIND DATA block on the sound ranging form (fig 124).

b. *Determining Angular Data.* The values of the elevation and azimuth angles corresponding

to the time at each layer limit are obtained to the nearest 0.1° from the control-recorder tape (fig 98). These angular data are entered in the WIND DATA block on the form.

c. *Determining Surface Wind Data.* The surface wind speed and direction are measured with an anemometer.

d. *Determining the 200-, 400-, 600-, and 800-Meter Layer Wind Data.* The distance traveled corresponding to the elevation angle of the balloon as it reaches each layer limit is obtained from table IVa, FM 6-16. These distances are plotted at the corresponding azimuth angles for each layer limit on plotting board ML-122. In addition, the offset release point data, when required, are plotted. The azimuth and horizontal distance to the offset release point are recorded on the surface line of the WIND DATA block on the sound ranging form as shown in figure 124. The

WEATHER DATA FOR SOUND-RANGING (FM 6-15)													
STATION				LOCATION				RE-LEASE TIME	DATE		HOURLY	FLIGHT NO.	
3D INF DIV ARTY				FT SILL, OKLA						LST	17 FEB 64	1130	3
WIND DATA								GMT	17 FEB 64	1730			
SOUND RANGING LAYER LIMIT (meters)	TIME AT LAYER LIMIT (minutes & seconds)			ELEVATION ANGLE (degrees & tenths)	AZIMUTH ANGLE (degrees & tenths)	HORIZONTAL DISTANCE (meters)	HORIZONTAL TRAVEL IN LAYER (meters)	TIME IN LAYER (minutes & tenths)	LAYER WIND DATA		WEIGHTED WIND DATA		
	30 GRAM BALLOON	PRESSURE MB AT LAYER LIMITS	RADIOSONDE TIME MINUTES AND TENTHS						DIRECTION (tens of miles)	SPEED (knots)	DIRECTION (tens of miles)	SPEED (knots)	
SUR	0.15	—	—	—	12.6	100			344	004	0	0	
200	0.54	946	0.6	33.2	335.2	310	240	0.6	249	013	0	0	
400	1.54	924	1.3	39.0	342.3	490	190	0.7	310	009	310	009	
600	2.54	903	2.0	35.3	351.1	850	370	0.7	325	017	0	0	
800	3.34	882	2.7	34.4	358.6	1170	350	0.7	351	016	0	0	
EFFECTIVE WIND (TOTALS)										310	009		
TEMPERATURE DATA				WIND WEIGHING FACTORS				DATA REPORTED TO SOUND RANGING SECTION					
SURFACE OBSERVATION DRY BULB °C WET BULB °C DEPRESSION °C VIRTUAL °C × 3 = °C = °C TIME OF DAY CORRECTION °C EFFECTIVE TEMPERATURE °C				400 METER LAYER WIND SPEED IS: (Check one) <input type="checkbox"/> 1 TO 2 TIMES 200 METER LAYER <input type="checkbox"/> OVER 2 TIMES 200 METER LAYER <input type="checkbox"/> LESS THAN 200 METER LAYER AND WITHIN 2 KNOTS OF SURFACE <input checked="" type="checkbox"/> LESS THAN 200 METER LAYER AND NOT WITHIN 2 KNOTS OF SURFACE				EFFECTIVE TEMPERATURE NEAREST 1/10 °C 26.8 °C EFFECTIVE WIND DIRECTION (tens of miles) SPEED (knots) 310 09					
PERIOD OF DAY AND TEMPERATURE CORRECTION (Check one) NIGHT +1.3°C AFTERNOON -1.3°C -0.6° ±0.0° +0.6°				SOUND RANGING LAYER NORMAL STRUCTURE SURFACE 0.2 200 METER 0.5 400 METER 0.15 600 METER 0.075 800 METER 0.075				RELEASE TIME 1730 GMT DELIVER TO 53 3/26 DELIVERY TIME 1750					
RADIOSONDE OBSERVATION VIRTUAL 27.0 °C × 3 = 81.0 THERMISTERS 26.2 °C 107.2 / 4 = 26.8 °C (Effective Temperature)				RECORDER KELLEY RAWLINSON				PLOTTER LARCHEVEQUE CHECKER CRAWLEY					

DA FORM 1 MAR 62 6-48

PREVIOUS EDITIONS OF THIS FORM ARE OBSOLETE.

Figure 124. Sound ranging form completed from electronic data.

<p style="text-align: center;">Computations for sound ranging effective temperature using the pilot balloon method</p> <p>Effective temperature: $T_s = (3 T_v + T) / 4$</p> <p>T_s = Sound ranging effective temperature T_v = Density virtual temperature T = Surface dry-bulb temperature</p> <p>1. Subtract wet-bulb reading from dry-bulb reading to obtain wet-bulb depression. 2. Obtain density virtual temperature (T_v) from table Ia FM 6-16 using dry-bulb reading and wet-bulb depression as arguments.</p> <p>Example:</p> <table style="width: 100%; border-collapse: collapse;"> <tr> <td style="padding-right: 20px;">Dry-bulb</td> <td style="padding-right: 20px;">28.0°C</td> <td style="padding-right: 20px;">28.0°C</td> </tr> <tr> <td>Wet-bulb</td> <td>25.2°C</td> <td></td> </tr> <tr> <td>Depression</td> <td>2.8°C</td> <td></td> </tr> <tr> <td>Virtual temperature</td> <td>32°C x 3 = 96.0°C</td> <td></td> </tr> <tr> <td></td> <td></td> <td>124.0°C / 4 = 31 °C</td> </tr> <tr> <td>Time of day correction (Night for this example)</td> <td></td> <td>+1.3°C</td> </tr> <tr> <td>Effective temperature</td> <td></td> <td>32.3°C</td> </tr> </table>	Dry-bulb	28.0°C	28.0°C	Wet-bulb	25.2°C		Depression	2.8°C		Virtual temperature	32°C x 3 = 96.0°C				124.0°C / 4 = 31 °C	Time of day correction (Night for this example)		+1.3°C	Effective temperature		32.3°C	<p style="text-align: center;">Metro day for sound ranging</p>  <ol style="list-style-type: none"> 1. When SUR wind exceeds 15 knots, use Afternoon (-1.3°C). 2. In rain, drizzle, and fog use no correction. 3. When SUR wind is 5-15 knots and sky is half to total overcast, use Afternoon (-1.3°C). 4. Otherwise use Metro day
Dry-bulb	28.0°C	28.0°C																				
Wet-bulb	25.2°C																					
Depression	2.8°C																					
Virtual temperature	32°C x 3 = 96.0°C																					
		124.0°C / 4 = 31 °C																				
Time of day correction (Night for this example)		+1.3°C																				
Effective temperature		32.3°C																				

Figure 124—Continued.

completed layer wind plot is shown in figure 126. The layer wind directions are measured for each layer as described in paragraph 167 and recorded on the form. The distance traveled for the 200-meter layer is measured from the offset plot or from the origin of the plotting board when the offset plot is not required. The distance traveled for each subsequent layer is measured from the plot of the preceding layer limit. The time in each layer is determined by computing the difference in time between consecutive layer limits. Then the layer wind speeds are computed on a slide rule by using the formula

$$\frac{\text{distance traveled in layer (in meters)} \times 0.0324 \text{ time in}}{\text{layer (in minutes and tenths of minutes)}} = \text{layer wind speed (knots)}.$$

These layer wind speeds are entered in the appropriate spaces in the WIND DATA block on the sound ranging form.

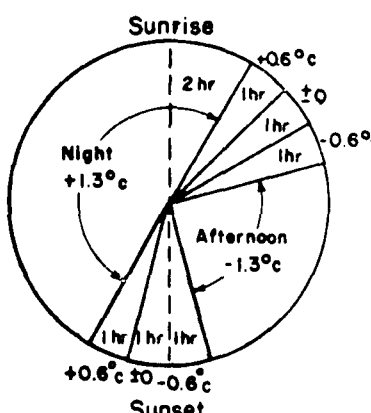
Figure 126. Completed layer wind plot for electronic data.

(Located in back of manual)

e. Effective Wind Direction and Speed. The effective wind for sound ranging is a total of the weighted values of the surface and layer winds.

There are four different wind structures—normal, 2, 3, and 4. Each wind structure has a set of weighting factors. Thus, the set of weighting factors used to compute the effective wind is selected according to the structure of the measured winds. The wind structure is determined by comparing the 400- and 200-meter layer wind speeds and, when required, the surface wind speed. The four wind structures, the corresponding sets of weighting factors, and the basis for their selection are given in the WIND WEIGHTING FACTORS block on the sound ranging form. In figure 124 structure 4 is used, since the 400-meter layer wind speed (9 knots) is less than the 200-meter layer wind speed (13 knots) and not within 2 knots of the surface wind speed (4 knots). After the wind structure has been determined, the box is checked as shown, and the surface and layer wind speeds and directions are multiplied by the corresponding weighting factors. These computations are tabulated for normal structure and structure 2 winds in table IVd, FM 6-16, so that the actual multiplication is unnecessary. The resulting weighted wind speeds and directions are entered in the last two columns of the WIND

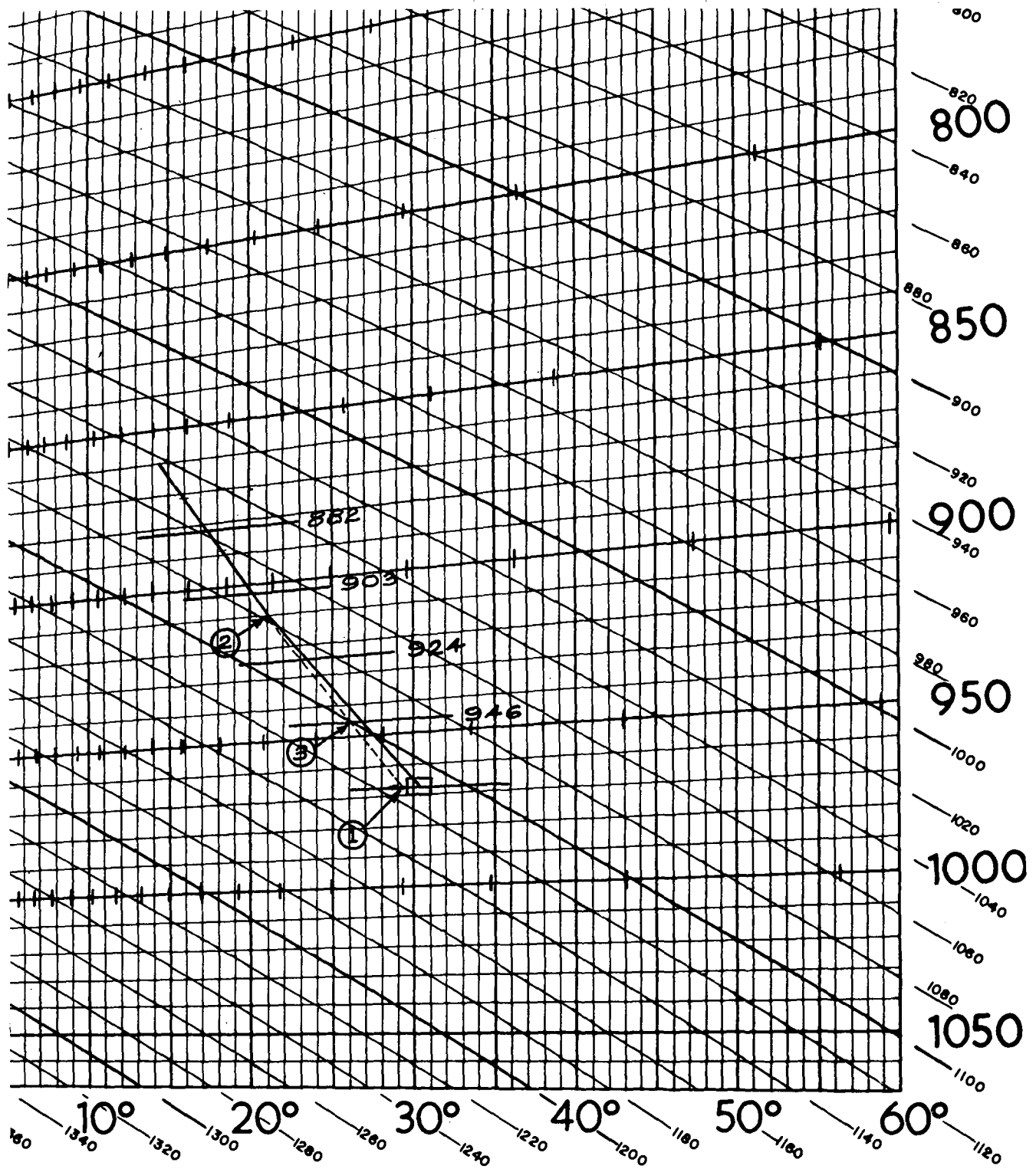

★Figure 125. Sound ranging layers plotted on chart ML-574/UM.

DATA Block on the sound ranging form and are totaled. These totals are the effective wind speed (9 knots) and direction (3100 mils and are recorded to the nearest knot and nearest 10 mils in the EFFECTIVE WIND section in the DATA REPORTED TO SOUND RANGING SECTION block.

f. Layer Wind Direction Passing 6,400 Mils. Close attention must be given to the direction of the layer winds and the manner in which they change from one zone to the next. When the wind direction between successive layers passes from the third (3,200 mils to 4,800 mils) or fourth (4,800 mils to 6,400 mils) quadrant to the first (0 to 1,600 mils) or second (1,600 mils to 3,200 mils) quadrant, or vice versa, and in so doing crosses the 6,400 mil direction, 6,400 must be added to the direction in the first or second quadrants before the application of weighting factors. For example, if the wind directions of 6,300 mils and 100 mils were averaged (added and divided by 2) the result would be 3,200 mils, an erroneous result. By adding 6,400 mils to the 100 mil value, the average result would be a correct direction of 6,400 mils. Before weighting, the layer wind directions must be adjusted by adding 6,400 mils where needed. The tables in FM 6-16 (table IVd) are con-

structed to weight directions up to 7,900 mils. When the totaled wind direction (total of the weighted wind direction values) is greater than 6,400 mils, 6,400 must be subtracted from the answer to obtain the corrected effective wind direction.

181. The Completed Sound Ranging Message

At the completion of all computations, the sound ranging message is transmitted to the using unit without delay. Only that information recorded in the block for DATA REPORTED TO SOUND RANGING SECTION is transmitted. These data consist of the effective temperature, effective wind direction and speed, and time of release. After the sound ranging message has been transmitted, the designation of the receiving unit and the time the message was delivered are entered on the form.

182. Validity and Frequency

The preparation of the sound ranging message by the artillery met section is completed before any other requirement. This will insure that the data are current. The data obtained by the electronic method are normally available for sound ranging every 2 hours.

CHAPTER 14

SOUND RANGING MESSAGE DEVELOPED FROM SURFACE
AND PILOT BALLOON OBSERVATIONS**183. General**

a. Sound Ranging Data. The data for the sound ranging message may be obtained by the sound ranging section using its TOE equipment. The description, use, care, and maintenance of this equipment is explained in chapter 6. As outlined in the previous chapter, the artillery met sections provide the sound ranging messages from measurements of the atmosphere aloft. However, because of distance and topography, this data may not be as valid as that obtained by the sound ranging section. In this situation, the sound ranging section will measure the data used to prepare the message by using the pilot balloon observation technique.

b. Selection of Observation Site. Ideally, the observation site should be centrally located, both laterally and in altitude, with respect to the sound base. However, an observation site near the command post of the sound ranging section will facilitate the dissemination and application of sound ranging weather data.

184. Procedure for Determining Effective Temperature

DA Form 6-48 (fig 127) provides a step-by-step method for determining the effective temperature based on surface observations.

a. Surface Observations. Surface observations of dry- and wet-bulb temperatures are taken with psychrometer ML-224, as explained in paragraph 52. The temperatures are entered in the SURFACE OBSERVATION section of the TEMPERATURE DATA block. These surface temperatures are measured and recorded to the nearest 0.1° C. The dry-bulb temperature is entered in two positions. In figure 127, the wet-bulb depression (3.9° C.) is obtained by subtracting the wet-bulb temperature (16.3° C.) from the dry-bulb temperature (20.2° C.).

b. Determining Surface Virtual Temperature. The surface virtual temperature is determined from the surface temperature observation and the virtual temperature table. Table Ia, FM 6-16,

is entered with the air temperature (dry-bulb) and the wet-bulb depression to the nearest 0.1° C. as arguments. The virtual temperature (22.0° C.) is obtained from the table to the nearest 0.1° C. and is recorded in the TEMPERATURE DATA block of the form. An example of determining surface virtual temperature is shown below.

Dry-bulb temperature	20.2° C.
Wet-bulb temperature	16.3° C.
Wet-bulb depression	3.9° C.
Virtual temperature from table ...	22.0° C.

c. Determining Effective Temperature. The effective sound ranging temperature is the sonic temperature in degrees Celsius at a height of 200 meters above the surface. Since there are no means available to the sound ranging section for measuring upper air temperatures, the effective temperature is determined by assuming a departure from the surface sonic temperature. At night, the effective temperature is obtained by adding 1.3° C. to the surface sonic temperature; in the afternoon, the effective temperature is obtained by subtracting 1.3° C. from the surface sonic temperature. The amount by which the surface sonic temperature must be corrected at any time of day or night is determined from the rear side of DA Form 6-48 (fig 124-cont), based on the flight release time, the weather conditions, and the times of sunrise and sunset. The times of sunrise and sunset are obtained from the survey information center (or from any other unit having access to an ephemeris or by estimation from the previous day) and are entered in the lower left corner of the form. For the release time in figure 127, the period of the day is afternoon and the surface virtual temperature correction is -1.3° C. The temperature correction for the period of the day is checked on the form and the surface sonic temperature correction is entered on the line for time of day corrections in the TEMPERATURE DATA block of the sound ranging form. The effective temperature (20.3° C.) is the algebraic sum of the surface sonic temperature (21.6° C.) and the time of day correc-

WEATHER DATA FOR SOUND RANGING																			
STATION		LOCATION				RE-LEASE TIME		DATE		FLIGHT NR									
3d Div Arty		Fort Sill, Okla				4 OCT 59		4 OCT 59		3									
WIND DATA																			
Sound ranging layer limit (meters)	Time at layer limit (minutes & seconds)		Elevation angle (degrees & tenths)		Azimuth angle (degrees & tenths)		Horizontal distance (meters)		Horizontal travel in layer (meters)		Time in layer (minutes & tenths)		LAYER WIND DATA		WEIGHTED WIND DATA				
	30 Gram balloon	Pressure MB at layer limits	Time minutes and tenths										Direction (tens of miles)	Speed (Knots)	Direction (tens of miles)	Speed (Knots)			
	SUR	0:15		27.0	197.0								030	14	006	2.8			
	200	0:54		26.9	208.1	390	390						050	14	025	7.0			
	400	1:54		18.5	212.6	1200	810						062	26	009	3.9			
600	2:54		17.2	216.8	1940	750						078	24	006	1.8				
800	3:54		16.7	220.9	2670	750						090	24	007	1.8				
TEMPERATURE DATA										WIND WEIGHING FACTORS									
Surface Observation										400 meter layer wind speed is:									
Dry bulb 20.2 °C										<input checked="" type="checkbox"/> 1 to 2 times 200 meter layer <input type="checkbox"/> over 2 times 200 meter layer <input type="checkbox"/> Less than 200 meter layer									
Wet bulb 16.3 °C										<input type="checkbox"/> Less than 200 meter layer and within 2 knots of surface <input type="checkbox"/> Less than 200 meter layer and not within 2 knots of surface									
Depression 3.9 °C										Normal structure 0.2									
Virtual 22.0 °C x 3 = 66.0 °C										Structure 2									
4										Structure 3									
Time of day correction 1.3 °C										Structure 4									
Effective temperature 20.3 °C										Sound ranging layer									
Period of day and temperature correction (Check one)										Surface									
Night +1.3°C										200 Meter									
Afternoon -1.3°C										400 Meter									
Transition -0.6° to +0.6°										600 Meter									
Radiosonde Observation										800 Meter									
Virtual Thermister °C x 3										<input type="checkbox"/> 0.2 <input type="checkbox"/> 0.5 <input type="checkbox"/> 0.15 <input type="checkbox"/> 0.075 <input type="checkbox"/> 0.15									
4										<input type="checkbox"/> 0.4 <input type="checkbox"/> 0 <input type="checkbox"/> 1.0 <input type="checkbox"/> 0 <input type="checkbox"/> 0									
Effective Temperature										<input type="checkbox"/> 0.15 <input type="checkbox"/> 0.15 <input type="checkbox"/> 0 <input type="checkbox"/> 0									
Observer										DATA REPORTED TO SOUND RANGING SECTION Effective temperature nearest 1/10 °C: <u>20.3</u> °C EFFECTIVE WIND Direction (tens of miles): <u>053</u> Speed (knots): <u>17</u> RELEASE TIME: <u>1730</u> GMT DELIVER TO: <u>53 3/26</u> DELIVERY TIME: <u>1800</u>									
TIME OF SUNRISE		TIME OF SUNSET		RECORDER				PLOTTER				CHECKER							
0600		1800		Donnelly				Jefferson				Reed							

PREVIOUS EDITIONS OF THIS FORM ARE OBSOLETE.

Figure 187. Sound ranging form completed for surface observation.

DA FORM 6-48, 1 MAR 62

tion (-1.3° C.) and is entered on the last line in the TEMPERATURE DATA block. This temperature is reported to the sound ranging section and is entered in the EFFECTIVE TEMPERATURE section in the DATA REPORTED TO SOUND RANGING SECTIONS block.

185. Procedure for Determining Effective Wind Speed and Direction

The effective wind for sound ranging is determined from periodic observations of the angular position of a balloon. When the visual method is used, a 30-gram pilot balloon (weighted off during inflation as described in paragraph 63) is released. The elevation and azimuth angles to the balloon are read at 15 seconds, 54 seconds, 1 minute 54 seconds, 2 minutes 54 seconds, and 3 minutes 54 seconds after release. The 15-second angular reading is used to determine the surface wind conditions. At the end of 54 seconds, 1 minute 54 seconds, 2 minutes 54 seconds, and 3 minutes 54 seconds, the balloon has ascended to heights of 200, 400, 600, and 800 meters, respectively. For sound ranging purposes these heights represent the limits of sound ranging layers of the atmosphere. The 200-meter sound ranging layer limit represents the top of a layer of the atmosphere extending from the surface to a height of 200 meters. The 400-meter limit represents the top of the sound ranging layer extending from the top of the preceding layer (200 meters) to a height of 400 meters above the surface. Similarly, the heights of 600 and 800 meters represents the tops of successive layers of the atmosphere which extend from the preceding layer limit (400 and 600 meters, respectively). The direction and speed of the wind within each of these layers are determined by the techniques described in *a* through *g* below. Then the layer wind values of speed and direction are weighted, and the weighted values are added to obtain the effective wind speed and effective wind direction. The effective wind computations are recorded in the WIND DATA block on the sound ranging form (fig 127).

a. Modifications to DA Form 6-48 (Weather Data for Sound Ranging). When a sound ranging message is prepared from pilot balloon observation data, the radiosonde columns in the WIND DATA block on the form are lined out.

b. Angular Data. The elevation and azimuth angles are read to the nearest 0.1° and the values are entered in the appropriate columns of the WIND DATA section of the form.

c. Determining Distance Traveled. The dis-

tance to the balloon at each time is obtained from table IVa, FM 6-16, and is entered on the sound ranging form. The values listed in the tables have been computed for the elevation angles at the time the balloon reaches each height (200, 400, 600, and 800 meters), thus eliminating the necessity of separate computations for each observation.

d. Plotting the Layer Winds. A plot of the horizontal projection of the path of the balloon is made on plotting board ML-122 by using the horizontal distances and corresponding azimuth angles read by the observer. The plot is labeled with the zone number for the data plotted and with any factor of scale expansion that was utilized. A completed layer wind plot is shown in figure 128. Since the equipment generally used for plotting the path of a pilot balloon is designed for plotting longer flight periods than that required in preparing data for sound ranging, normal scale plotting of the sound ranging data often results in all of the layer plots falling close to the origin. If wind speeds are low, it is advantageous to increase the scale of the plot. The horizontal distances may be plotted 10, 5, or 2 times the actual values entered on the sound ranging form.

e. Surface Sound Ranging Layer Wind Speed and Direction. The surface sound ranging wind speed is obtained from table IVb, FM 6-16, based on the 15-second reading of the elevation angle. The surface sound ranging wind direction for balloons released at the theodolite is obtained from table IVe, FM 6-16, based on the 15-second reading of the azimuth angle.

f. Determination of Layer Wind Speeds. The layer wind speeds are determined by entering table IVc, FM 6-16, with the argument of horizontal travel in layer.

g. Determination of Layer Wind Directions. The technique used in determining layer wind directions for sound ranging is similar to that used in determining zone wind directions. The layer wind directions for all layers are read directly from the plots on plotting board ML-122 by using scale ML-577. The reading of layer wind direction is facilitated by placing a straight edge along the two plotted points representing the base and top of a given layer and then drawing a reasonably long line beyond the upper plotted point as shown in figure 128. The length of this line should permit direction to be read from the outside edge of scale ML-577 when the center of the scale is placed over the lower plotted point of any layer. The scale is oriented with the north

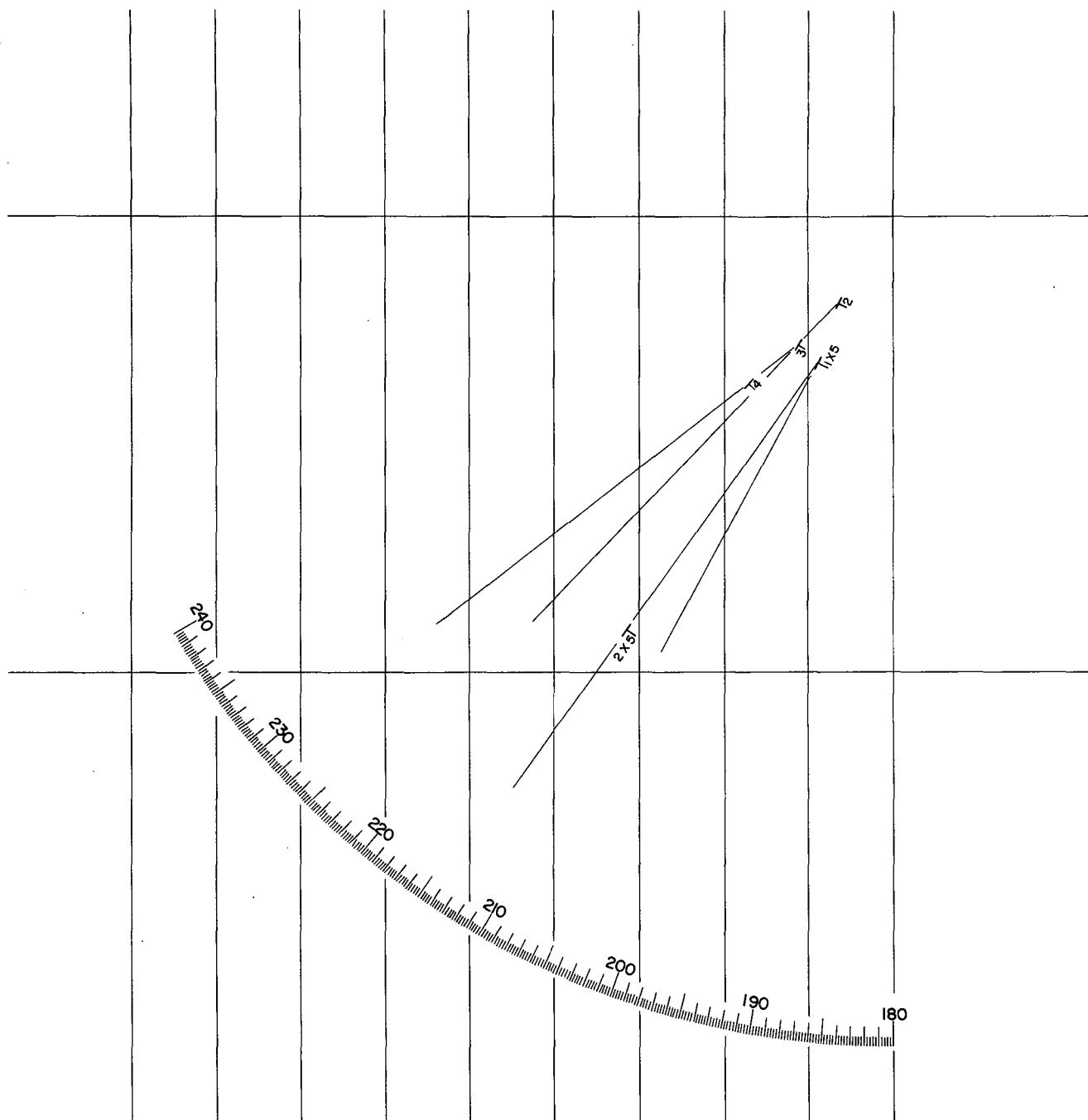

Figure 128. Completed layer wind plot for surface observation.

line parallel to the vertical lines of the plotting board. (The north arrow of the scale points toward the top of the plotting board.) Each layer wind direction is read from the scale to the nearest 10 mils. These data are recorded in their respective blocks in the LAYER WIND DATA section of the form.

h. Effective Wind Direction and Speed. The effective wind for sound ranging is a total of the

weighted values of the surface and layer winds. There are four wind structures—normal, 2, 3, and 4. Each wind structure has a set of weighting factors. The set of weighting factors used to compute the effective wind is selected according to the structure of the measured winds. The wind structure is determined by comparing the 400- and 200-meter layer wind speeds and, when required, the surface wind speed. The four wind

structures, the corresponding sets of weighting factors, and the basis for their selection are given in the WIND WEIGHTING FACTORS block on the sound ranging form. In the case of the data recorded on the form in figure 127, the layer wind speeds are within the normal structure, since the 400-meter layer wind speed (26 knots) is 1 to 2 times the 200-meter layer wind speed (14 knots). After the wind structure has been determined, the box is checked as shown, and the surface and layer wind speeds and directions are multiplied by the corresponding weighting factors for that structure. These computations are tabulated for normal structure and structure 2 in table IVd, FM 6-16. The resulting weighted wind speeds and directions are entered in the last two columns of the WIND DATA block on the sound ranging form and are totaled. These totals are the effective wind speed and direction and are entered to the nearest knot and to the nearest 10 mils, respectively, in the EFFECTIVE WIND section in the DATA REPORTED TO SOUND RANGING SECTION block.

i. Layer Wind Direction Passing 6,400 Mils. Close attention must be given to the direction of

the layer winds and the manner in which they change from one layer limit to the next. The same procedure outlined in paragraph 180f should be followed.

186. Comparison With Electronic Data

The sound ranging message prepared from the pilot balloon and surface observation method should be compared with the electronic data available at the met section. This comparison is made primarily for temperature rather than wind direction and speed. The reason for this comparison is that the temperature is relatively constant over a large horizontal area, whereas the wind direction and speed are not. The presence of abnormal temperature lapse rates within the area from the surface to a height of 200 meters will invalidate the period of day correction. Therefore, the sound ranging section should check with the met section for the presence of an abnormal temperature lapse rate. If present, the difference in temperature between the surface and 200 meters obtained by the electronic sounding should be used in place of the time of day correction.

PART FOUR
METEOROLOGY FOR FALLOUT PREDICTION
CHAPTER 15
GENERAL

187. General

The prediction of fallout from both friendly and enemy nuclear weapons is accomplished by chemical corps personnel at division, corps, and field army levels. The division fire support element (FSE) will incorporate the resulting fallout predictions in its planning. In order to make optimum meteorological support available to army elements engaged in the prediction of fallout, a supporting system has been devised. Primary responsibility for providing meteorological data has been assigned to artillery met sections. The Air Weather Service (AWS) is available to provide forecast data when army meteorological data are not available. In the communications zone, the AWS will be the primary source of met data for the production of fallout predictions. However,

the information contained in this part of the manual is confined to met data furnished by artillery met sections to units of the field army and the techniques and procedures employed by the met section in measuring and reporting data used in fallout predictions.

**188. Action Upon Receipt of Fallout
Met Message**

Upon receipt of the fallout met message by the G2/FSE a fallout wind vector plot, an effective wind message, and a prestrike fallout prediction are prepared by the chemical, biological, and radiological element (CBRE) in accordance with the procedures described in TM 3-210, U.S. Army Fallout Prediction Method.

CHAPTER 16

FALLOUT METEOROLOGICAL REQUIREMENTS

189. General

In order to furnish the required meteorological data for fallout prediction, the artillery met section provides fallout met messages on the following daily schedule:

Fallout Met Message Release Schedule

<i>Time (GMT)</i>	<i>Height required (meters above MDP)</i>	<i>Minimum acceptable height (meters above MDP)</i>
0000	30,000	24,000
0200	18,000	14,000
0400	18,000	14,000
0600	30,000	24,000
0800	18,000	14,000
1000	18,000	14,000
1200	30,000	24,000
1400	18,000	14,000
1600	18,000	14,000
1800	30,000	24,000
2000	18,000	14,000
2200	18,000	14,000

Note. Actual time of release will be not more than 30 minutes earlier or 30 minutes later than the scheduled release time.

190. Information Contained in the Fallout Met Message

The fallout met message will contain the following information:

a. Wind speed and direction above the met datum plane (MDP) in 2,000-meter zones.

(1) Wind direction is reported in tens of mils.

(2) Wind speed is reported to the nearest knot.

★*b.* If an observation is terminated before the desired height is reached, the following action will be taken:

(1) Obtain information from the adjacent unit as prescribed in paragraph 33.

(2) Make a second release as soon as possible, providing the release can be made before 1 hour after the scheduled release time.

(3) Compute and transmit data for both observations.

★*c.* Other met requirements, in addition to fallout met requirements, normally will be met.

191. Assignment of Flight Schedules

Since all artillery met sections have the capability of measuring and reporting high-altitude data, the fallout meteorological requirements should be rotated among the sections within the corps area to reduce the workload on any one section. Assignment of release schedules normally will be specified in the artillery and/or air defense support annex to the operations order. Coordination of fallout met requirements must be accomplished by the corps artillery met staff officer; overall supervision is coordinated at army artillery.

CHAPTER 17

DETERMINATION OF HIGH-ALTITUDE WINDS

192. General

a. Artillery met sections usually are assigned the mission of providing a fallout met message in conjunction with a sounding being developed for an artillery message. When this is the case, the fallout message is developed concurrently with a computer and/or NATO met message. Since only true wind directions and speeds are required for a fallout message, these data can be extracted from the computer zone wind plots employing the same techniques used in extracting the NATO zone winds. Caution must be exercised when measuring from one fallout zone to another. Fallout zones are identified by enclosing the zone number in a triangle (fig 100). Paragraph 195 explains how DA Form 6-46, marked for fallout, is used when the fallout message is prepared concurrently with a computer and/or NATO artillery message.

b. When an artillery met section is required to furnish a fallout message only, the instructions in paragraphs 193 and 194 should be followed.

193. Requirements and Equipment for High-Altitude Soundings

a. Installation of the met station, organization of personnel, preflight checks, and baseline check procedures are the same as those for an artillery sounding described in chapter 7.

b. Equipment includes—

- (1) High-altitude balloons.
- (2) Fast-rising balloons.
- (3) Hypsometric radiosondes.

c. Special requirements are as follows:

- (1) Equipment must be tuned for peak performance.
- (2) Because of the long period of time required for an observation—
 - (a) Generators must be serviced.
 - (b) Paper tape rolls must be checked for sufficient paper.
 - (c) Teams should be rotated just before high-altitude requirements, if practical.
- (3) During the high-altitude soundings, data for sound ranging, ballistic, or computer

messages are transmitted immediately and not held until the completion of all requirements.

(4) Balloons must receive special handling (para 62c and 63a).

194. Determination of Fallout Zones on Chart ML-574/UM

a. The sounding is plotted on chart ML-574/UM, and zones are balanced in the same manner as artillery zones (para 140).

b. Zone height scale ML-573 is graduated for fallout zones (fig 99). Zones are measured by balancing areas on the virtual temperature curve. When artillery zones are measured, the top of each artillery zone corresponding to a fallout zone is marked as a fallout zone (fig 89), and the pressure is entered to the right of the sounding curve.

c. The pressure-time chart is plotted in the same manner as for an artillery flight as discussed in chapter 7.

195. Completion of Fallout Wind Data

a. *Modification of Rawin Computation Form (DA Form 6-46)*. DA Form 6-46 (fig 129) is used to record the data for fallout winds; however, some modifications are necessary.

(1) The heights of the fallout zones are entered in column (1); each zone is 2,000 meters thick; therefore, the tops of the fallout zones would be at heights of 2,000, 4,000, 6,000, 8,000, 10,000 meters, etc, up to 30,000 meters.

(2) Columns (11) and (12) are lined out as ballistic winds are not plotted for a fallout message.

(3) In the lower left corner the message type "fallout" is checked.

(4) The block for the ballistic wind plotter's signature is crossed out.

b. *Columns (2)-(6), DA Form 6-46*. Data are entered on DA Form 6-46 as follows:

(1) *Column (2)*. Pressure at top of each fallout zone is obtained from chart ML-574/UM and entered in column (2).

(2) *Column (3)*. Time at top of each zone is

RAWIN COMPUTATION (FM 6-15)													
STATION				LOCATION				RE-LEASE TIME		DATE		HOUR	FLIGHT NO.
3D INF DIV ARTY				FT SILL, OKLA				LST 17 FEB 64		1730		1730	3
ZONE NUMBER	ZONE HEIGHT (meters) (1)	PRESSURE AT TOP OF ZONE (2)	TIME AT TOP OF ZONE (3)	ELEVATION ANGLE (degrees & tenths) (4)	AZIMUTH ANGLE (degrees & tenths) (5)	HORIZONTAL DISTANCE (meters) (6)	HORIZONTAL TRAVEL IN ZONE (meters) (7)	TIME IN ZONE (minutes & tenths) (8)	ZONE WIND DATA		BALLISTIC DATA		
									AZIMUTH (10 miles) (9)	SPEED (knots) (10)	AZIMUTH (100 miles) (11)	SPEED (knots) (12)	
OFFSET	SUR								SUR	310	SUR	004	SUR
1			6.8				1760	6.8		366		008	
2			13.3				2670	6.5		513		013	
3			20.2				3440	6.9		572		016	
4			26.7				1940	6.5		601		010	
5			33.1				2580	6.4		377		013	
6			39.6				4170	6.5		379		021	
7			45.6				3340	6.0		411		017	
8			51.5				3320	5.9		635		018	
9			57.6				4480	6.1		035		024	
10	20000		63.9				4770	6.3		132		025	
11	22000	40	69.4	76.8	105.4	5140	3710	5.5		274		022	
12	24000	29	75.0	80.0	206.2	4220	7240	5.6		135		042	
13	26000	21	80.5	74.4	241.9	7230	4530	5.5		169		027	
14	28000	15	86.4	65.0	253.0	12990	6040	5.9		155		033	
15	30000	11	92.2	56.7	260.6	19590	6920	5.8		169		039	
16													
MESSAGE TYPE (CHECK ONE) (13)				ZONE WIND COMPUTER				ZONE WIND PLOTTER				BALLISTIC WIND PLOTTER	
BALLISTIC		FALLOUT		KING				BLAKEWAY					
S	A	COMPUTER											

DA FORM 6-46
1 MAR 62

PREVIOUS EDITION OF THIS FORM IS OBSOLETE.

Figure 129. Rawin computations for fallout met message.

determined from the pressure-time chart using pressure from column (2) and is entered in column (3).

(3) Columns (4) and (5). Elevation and azimuth angles are obtained from the control-recorder tape by using the time at top of each zone in column (3) and are entered in columns (4) and (5).

(4) Column (6). Distances traveled are obtained from table Ig, FM 6-16, and entered to the nearest 10 meters in column (6).

c. Wind Plots. Azimuth angles (column 5) and distances traveled (column 6) are plotted on plotting board ML-122.

d. Columns (7)-(10), DA Form 6-46.

(1) Column (7). Distance traveled in zone is measured directly on the plotting board with rule ML-126A. Travel is measured between two suc-

cessive zone wind plots. Travel for zone 1 is measured from the offset release point to zone 1 (0-2,000 meters), zone 2 is measured from zone 1 to zone 2 (2,000 to 4,000 meters), etc, and the values are entered in column (7) to the nearest 10 meters.

(2) Column (8). Time in zone is determined from the information in column (3). The time in zone for zone 1 is carried over from column (3) (the time at top of zone 1). The time for zone 2 is determined by subtracting the time at top of zone 1 from the time at top of zone 2 and the difference is entered in column (8). For example, the time at top of zone 1 is 6.8 and the time at top of zone 2 is 13.3. The difference of 6.5 is entered in column (8).

(3) Column (9). Wind directions are also measured from the zone wind plots with scale

★ML-577. Scale ML-577 is oriented over the offset release point, and the azimuth is measured to the fallout zone 1 plot. Zone 2 azimuth is measured from zone 1 to zone 2, etc. The azimuths are entered in column (9) to the nearest 10 mils. For a detailed explanation, see paragraphs 147 and 148.

(4) *Column(10)*. Wind speed in knots is

determined in the same manner as artillery zone winds discussed in paragraph 147*n*. Wind speeds are recorded in three digits in column (10) of DA Form 6-46.

e. Checking. The procedure for checking fallout message computations is the same as that for artillery messages.

CHAPTER 18

DETERMINATION OF THE TROPOPAUSE

★196. Description and Significance of the Tropopause

The tropopause is the boundary between the lowest layer of the atmosphere, the troposphere, and the next higher layer, the stratosphere. Usually at the tropopause there is a relatively distinct change in the lapse rate of temperature. Above the tropopause, the temperature does not decrease as rapidly with an increase in altitude as it does below the tropopause. Because of this change in lapse rate, the atmosphere above the tropopause is relatively stable and any vertical air motion will tend to stop or slow down as it reaches the tropopause level.

197. Criteria for Locating the Tropopause

The following three criteria are used for locating the tropopause:

a. The tropopause lies between 600 and 30 millibars.

b. The tropopause level temperature is lower than -30°C .

★c. The tropopause is selected at the lowest level at which the lapse rate decreases to 2°C . per kilometer or less and then averages 2°C . per kilometer or less in the 2 kilometer layer immediately above that level (para 198*c*).

198. Measurement of Height(s) of Tropopause(s)

★a. Where required, the height of the tropopause is evaluated on chart ML-574/UM at a significant level which meets the criteria in paragraph 197. A check must be made for the presence of more than one tropopause, since it is possible for several tropopauses to exist.

b. A solid sloping line representing a lapse rate of 4°C . per 2,000 meters has been con-

structed on scale ML-573 and labeled "Tropopause Criteria" for use as a template for determining the height of the tropopause on chart ML-574/UM.

c. The template is placed on chart ML-574/UM with the guidelines parallel to the isotherms on the chart and to meet the criteria in paragraph 197*a* and *b*. The template is moved along the sounding curve (fig. 130) until the base of the solid sloping line is at some significant level point on the curve. When the sounding curve between this level and the next significant level is on or to the right of the lapse rate line on the template and when the sounding curve at 2,000 meters above this level is also on or to the right of the lapse rate line on the template, the level tested is the tropopause. This is true regardless of the configuration of the sounding curve within the 2,000 meter layer so long as no point within the stratum falls to the left of the lapse rate line (fig. 131). If the above conditions are not met, the template is moved to succeeding significant levels until all criteria are met.

d. The height of the tropopause is the lowest significant level found on chart ML-574/UM which meets the criteria in paragraph 197.

e. After the criteria have been met, the height of the tropopause is measured as follows:

★(1) The height of the base of the tropopause above the preceding zone is measured with the height scale in meters on scale ML-573 (fig. 130).

★(2) The height measured is added to the height of the preceding zone.

★Example: The base of the tropopause is measured to be 80 meters above computer zone 21 (15,000 meters). The height of the tropopause is 15,080 meters (15,000 meters + 80 meters) and reported as 151 (in hundreds of meters).

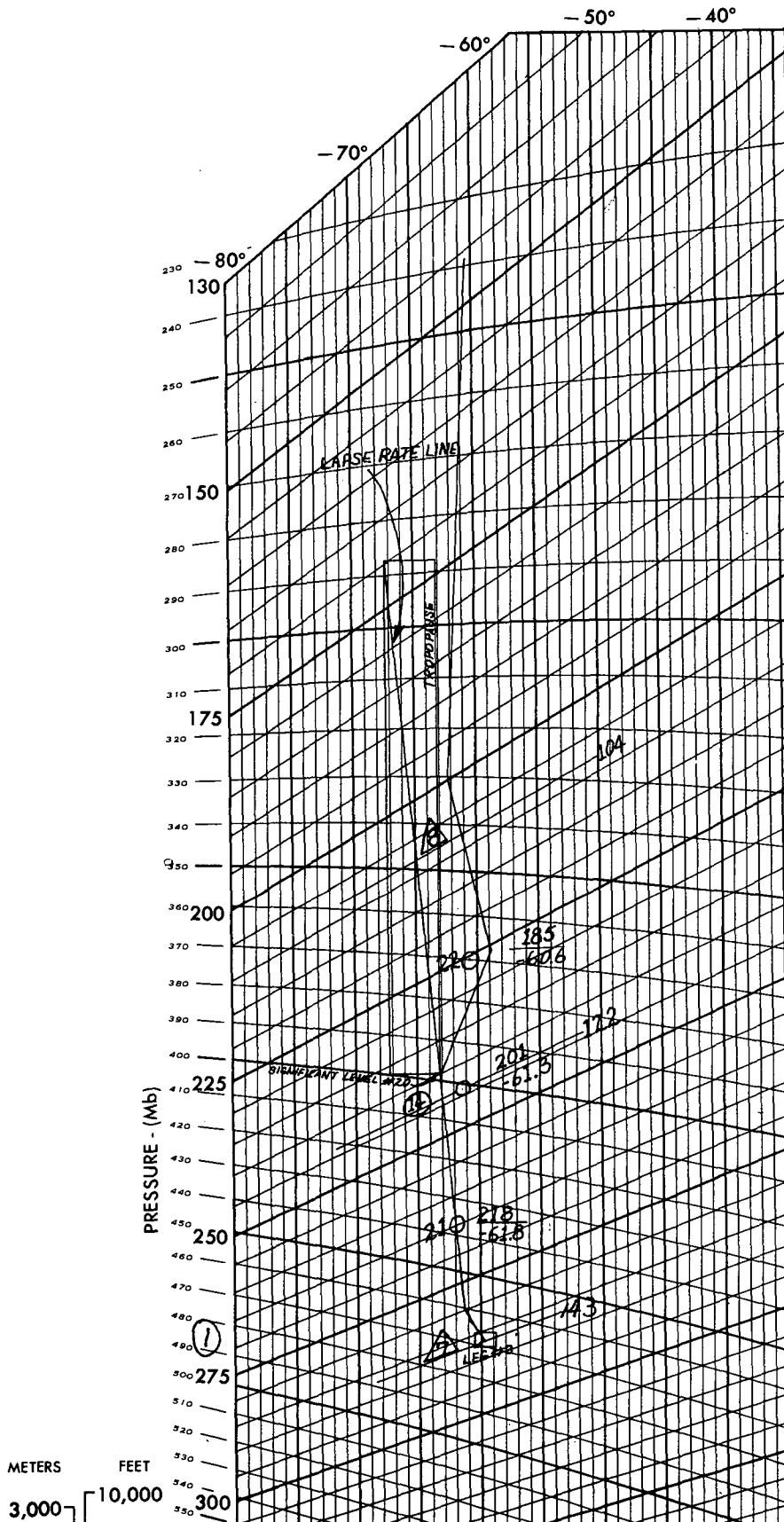
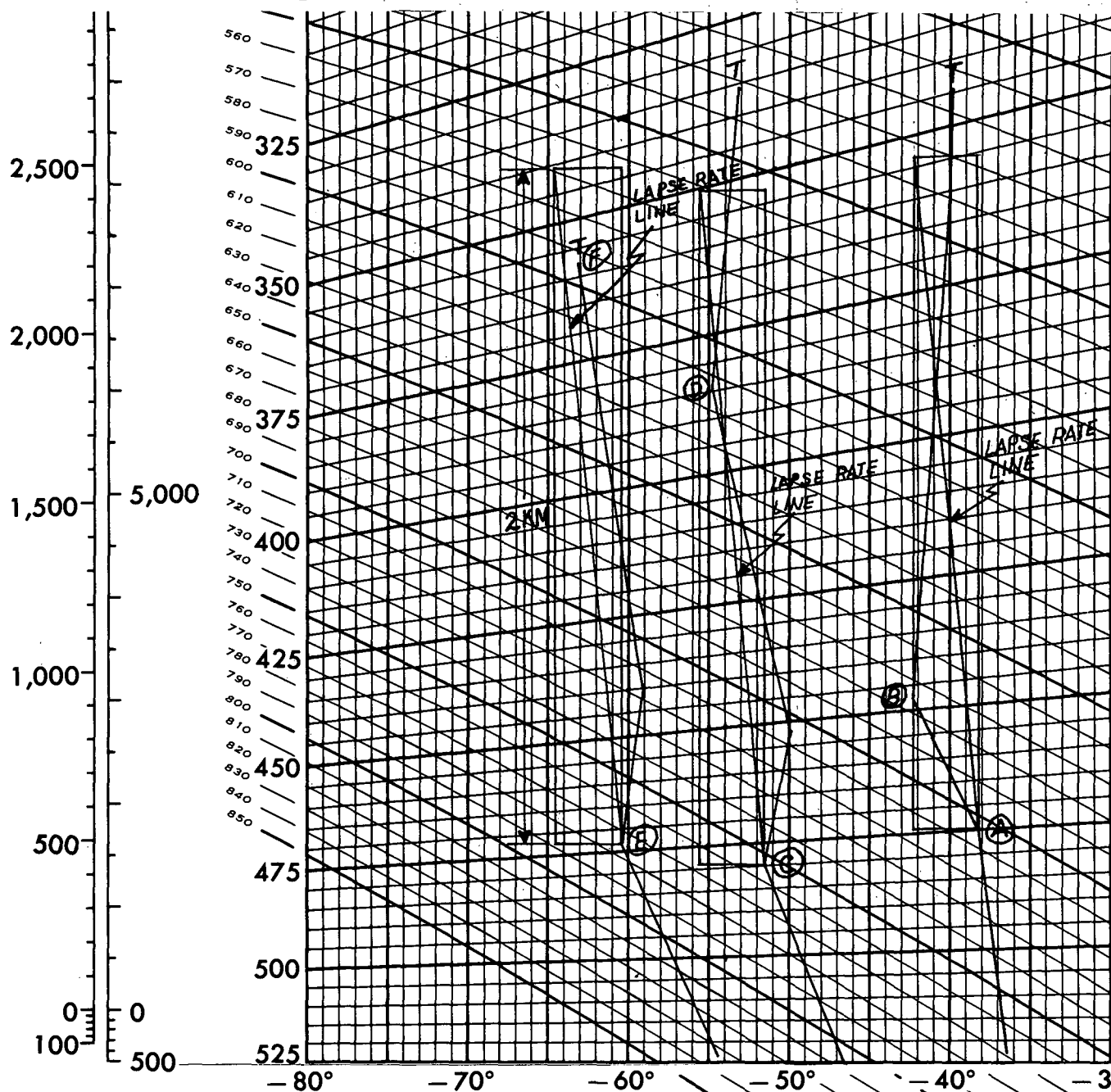

Figure 130. Determination of tropopause.



NOTE: Point (A) cannot be regarded as the tropopause due to point (B) being to the left of the "lapse rate line" of the template.

Point (C) cannot be regarded as the tropopause due to point (D) falling to the left of the "lapse rate line" of the template.

Point (E) cannot be regarded as the tropopause due to the termination of the flight within the 2KM layer, point (F)

Figure 131. Examples of significant levels that do not meet the criteria for a tropopause.

CHAPTER 19

ENCODING AND TRANSMISSION OF FALLOUT METEOROLOGICAL MESSAGE

★199. General

Met data for fallout prediction are recorded on DA Form 3676, (Fallout Met Message) (fig. 132). Use of this form is described on the back of the form (fig. 132). The data recorded on the form are encoded as follows:

a. Octant and Location. The area is identified by either a geographic location or a coded location of the met station. In either case, the location is preceded by a number (0, 1, 2, 3, 5, 6, 7, or 8) from the Q code which designates the octant of the globe in which the station is located. The geographic location of the met station may be determined from a military map and are recorded in degrees and tenths of degrees. If the longitude is equal to 100° or more, the first digit, 1, is dropped. For example, latitude 32° 30' north, longitude 146° 50' west would be encoded as 1 325 468. When operations require that the station be identified by a code word, the Q code number 9 is used to signify that the next six digits are a coded location of the met station. For example, if the coded location is WALNUT, the octant and location would be encoded as 9 WALNUT.

b. Date. The day of the month is entered in two digits, e.g., 17 indicates the message is for the 17th day of the month.

c. Time. The release time in hours and tenths of hours is entered in three digits (000 through 239).

d. Duration of Validity. Enter digit representing duration of validity in hours from 1 to 8; code figure 9 indicates 12 hours.

e. Station Altitude. The altitude of the met station (MDP) above mean sea level is entered in tens of meters. The altitude of the station may be determined from a military map or from the survey section and is encoded in three digits; e.g., 036 indicates the station is 360 meters above mean sea level (MSL).

f. Line Number. The line number is identified by two digits which correspond to the zone number. The first line number, 00, indicates surface;

01, surface to 2,000 meters; 02, 2,000 meters to 4,000 meters etc.

g. True (Zone) Wind Data. Wind direction is encoded in three digits in tens of mils. Wind speed is enforced in three digits to the nearest knot. The number 310 indicates the wind direction is 3,100 mils, and the number 004 indicates a speed of 4 knots.

h. Remarks. The REMARKS block is used to record other pertinent data.

i. Message Format for Transmission. The fallout met message is transmitted in a certain code group format, e.g., METFMQ LaLaLaLoLoLo (or XXXXXX) YYGoGoGoGhhh ZZ ddd FFF ZZ ddd FFF ZZ ddd FFF, etc.

<i>Code Group</i>	<i>Explanation</i>
METFM	Fallout met message.
Q	Octant of globe in a numerical code.
LaLaLaLoLoLo (or XXXXXX)	Location of met station.
YY	GMT date of beginning of valid time period.
GoGoGo	Beginning of valid time period in hours and tenths of hours (GMT).
G	Digit that represents duration of validity.
hhh	Height of met station (MDP) in tens of meters.

<i>Code Group</i>	<i>Explanation</i>
ZZ	Line number of fallout message.
ddd	Wind direction expressed in tens of mils.
FFF	Wind speed expressed in knots.

200. Transmission of Data

Fallout met messages are transmitted by the most expeditious means to fire support elements. It is the responsibility of the corps fire support element of the TOC to forward messages to the army tactical operations center. Artillery met stations operating in the army service area will forward fallout messages through army artillery headquarters to army tactical operations center.

FALLOUT MET MESSAGE							
For use of this form, see FM 6-15; the proponent agency is United States Continental Army Command.							
IDENTIFICATION	OCTANT	LOCATION		DATE	TIME (GMT)	DURATION (HOURS)	STATION WEIGHT (10'S M)
		L _a L _a L _a or xxx	L _o L _o L _o or xxx				
METFM	Q						
METFM	9	WALNUT		17	180	4	036
ZONE HEIGHT (METERS)	LINE NUMBER	TRUE WIND		ZONE HEIGHT (METERS)	LINE NUMBER	TRUE WIND	
		DIRECTION (10'S MILS)	SPEED (KNOTS)			DIRECTION (10'S MILS)	SPEED (KNOTS)
	ZZ	ddd	FFF		ZZ	ddd	FFF
SURFACE	00	310	004	16000	08	635	018
2000	01	366	008	18000	09	035	024
4000	02	513	013	20000	10	132	025
6000	03	572	016	22000	11	274	022
8000	04	601	010	24000	12	135	042
10000	05	377	013	26000	13	169	027
12000	06	379	021	28000	14	150	033
14000	07	411	017	30000	15	169	039
REMARKS							
RECEIVED FROM: DELIVERED TO:					DATE AND TIME (GMT)		
3D INF DIV ARTY FSCE					17 FEB 70/1836		
RECORDER BARTLETT							
CHECKER CROW							

DA FORM 3676
1 JAN 71

REPLACES DA FORM 6-58, 1 MAR 62, WHICH IS OBSOLETE

★Figure 132. DA Form 6-58 (Fallout Met Message).

THE FALLOUT MET MESSAGE IS ENCODED AS FOLLOWS

1. The message is arranged in groups to be conveniently transmitted by radio or teletypewriter.

2. Information data: In the first group, the first five letters denote that the message is a fallout message and the digit denotes the "Q" code of the global octant of the met station. The next group of six digits denote the location of the met station in degrees and tenths of degrees. When 9 of the "Q" code is used, the six digits denote the clear or coded location of the met station. The third group of digits denote the day of the month, time of commencement of validity in hours and tenths of hours (Greenwich Mean Time) and duration of validity, in hours from 1 to 8; code figure 9 indicates 12 hours. The three digits of the 4th group denote the height of the met station (Met Datum Plan) above sea level in multiples of 10 meters. All succeeding groups of eight-digit groups are true zone wind data.

3. The following specimen message was transmitted by teletypewriter.

METFM1 623465 290206 025 00026015
 01030021 02046023

EXPLANATION:

- Group 1 Fallout message. Met station located in global octant Nr 1. (N Lat 90° -180° W)
- Group 2 Center of area of applicability of the message (station location) is 62° 18' N; 146° 30' W
- Group 3 29th day of the month. Valid time is from 0200 to 0800 hours GMT.
- Group 4 Met station is 250 meters above mean sea level.
- Group 5 For line 00 (surface) the true wind direction is 0260 mils, wind speed is 15 knots.
- Group 6 For line 01 (0-2000 meters) the true wind direction is 0300 mils, wind speed is 21 knots.
- Group 7 For line 02 (2000-4000 meters) the true wind direction is 0460 mils, wind speed is 23 knots.

Q Code for Octant of Globe

0-North Latitude	0-90 West Longitude	0-90 West Longitude
1- " "	90-180 West	90-180 West
2- " "	180-90 East	180-90 East
3- " "	90-0 East	90-0 East
4-Not used		
5-South Latitude		
6- " "		
7- " "		
8- " "		
9-Used when the location of the meteorological station is not indicated by latitude and longitude.		

★Figure 132—Continued.

PART FIVE

AIR WEATHER SERVICE

CHAPTER 20

ORGANIZATION AND MISSION OF THE AIR WEATHER SERVICE WITH THE U.S. ARMY

Section I. INTRODUCTION

201. Requirement for Weather Support

Throughout history, weather conditions have played a large part in the success or failure of military operations. The complexity of present day weapons systems and surface combat forces, with their associated training requirements and employment tactics, and the continued necessity for the estimate of enemy capabilities require maximum consideration of weather conditions. The weather conditions must be carefully considered part of any military plan or operation.

202. Objective of Military Weather Service

The primary objective of a military weather service is to provide meteorological and environmental information to insure the full and effective employment of military forces. This weather service must maintain the same operational readiness as the unit or command it supports. It is necessary that this service be completely aware of the operational and planning factors, and it must have the technical and organizational capabilities to provide service to all echelons of the supported command.

203. Functions of a Military Weather Service Unit

A weather service unit has two basic functions.

a. It produces weather information, including reports of current weather conditions, forecasts of future weather conditions, and studies of past weather conditions as applied to specific planning requirements. This is accomplished by the collection, analysis, and interpretation of meteorological data at all available altitudes in and around operational areas.

b. It advises commanders and staff officers on meteorological factors that affect operations and

plans being considered. This includes presenting, interpreting, and advising on forecasts and climatological probabilities of weather conditions.

204. United States Meteorological Services

a. In 1870, the U.S. Army Signal Corps established the first United States meteorological service. The National Weather Service of the United States was established in 1891. Known as the U.S. Weather Bureau, this organization assumed the meteorological service then performed by the Signal Corps.

b. Military weather service came into being when personnel of the U.S. Weather Bureau were assigned to the Signal Corps for the purpose of supplying military weather support for aircraft, artillery, chemical, and other operations.

c. When the importance of meteorological service to aviation was recognized in 1937, the responsibility for U.S. Army weather service was transferred from the Signal Corps to the Army Air Corps.

d. Provisions for the weather support organization of the United States Air Force, Air Weather Service, were established in the Unification Act of 1947. Additional interservice agreements have charged the Air Weather Service with the responsibility for providing weather support to the United States Army. The Army, however, has maintained the capability of meeting certain of its meteorological requirements, for example the upper air data used by artillery. The U.S. Navy, on the other hand, has complete meteorological activities. The Special Assistant for Environmental Services (SAES) exists within the Joint Chiefs of Staff organization to accomplish joint planning of interdepartmental concern to insure maximum effectiveness and economy of a military weather service.

205. Weather Service Data Requirements

Climatological studies and operational forecasts cannot be prepared without meteorological data. Meteorological data must be global in scope, since military forces possess a worldwide capability and cannot be supported by a meteorological service that has a limited capability. To obtain a worldwide capability, weather data supplied by both friendly and unfriendly nations must be utilized. With this condition existing it is absolutely

necessary in peacetime that the military weather service cooperate with all other meteorological services to insure full and free access to current data. To accomplish this, the military weather service must—

- a. Exchange data with other meteorological services.
- b. Conform to established practices of the World Meteorological Organization.
- c. Cooperate with national services with jurisdiction over areas of military interest.

Section II. AIR WEATHER SERVICE SUPPORT FUNCTION AND ORGANIZATION WITH THE ARMY

206. General

a. Because of the complexity of modern warfare, many diverse military forces are created. These military forces require a wide variety of weather data to support their plans and operations. Operational requirements of the Air Weather Service vary from reporting the current weather to making extended weather forecasts at any location in the world.

b. It is essential that the effect of weather conditions be carefully considered in any specific military operation. Winds aloft may limit the range of aircraft, temperature may limit the payload of aircraft, and cloud conditions over the target may determine the type of ordnance which will be used. Winds may effect the accuracy of the ordnance delivered. Weather factors affect the efficiency of nuclear weapon systems.

c. Weather support service can attain optimum effectiveness only when the weather personnel know the capabilities, doctrine, plans, and procedures of the command they serve. Similarly, the commanders and operational personnel must understand and appreciate the nature of meteorology and the capabilities and limitations of the weather support organization.

207. Character of Weather Services

a. Weather service support is tailored to meet the specialized capabilities of the command supported. The areas of responsibility and operational authority of commands are established to effect the most economical employment of available forces and weapons. While there is some fundamental similarity among all types of weather services, this similarity is of little consequence when the vastly different types of weather service required to support the capabilities of the entire army are considered. Experience proves that the forecast capability is greatly improved by

limiting the service to one specific task at a time. Economy and concentration of effort are achieved by the specialization of meteorological requirements peculiar to the command supported. Conversely, when forecasts are required for all places and all elements at all times, the forecast capability suffers accordingly.

b. The wide dispersion of Army forces on the nuclear battlefield and sophisticated weapon systems increase the Army's requirements for weather service support. With the advent of the concept of vertical envelopment combined with lateral envelopment, the requirements have been greatly magnified. The area of weather interest of a field army extends 480 kilometers forward and 160 kilometers behind the forward edge of the battle area (FEBA). Although lateral distances may vary considerably, this distance is generally considered to be 480 kilometers. Within this relatively small volume of the atmosphere, specialized service is required for all elements of the field army.

208. Organization for Army Support

A part of the mission of the Air Weather Service is to provide weather support to the army. Providing weather service for a field army is the responsibility of a single Air Weather Service (AWS) organization, functionally aligned with the field army. All AWS personnel attached to army units within the field army organization are under the command of the senior AWS officer attached to the field army. This commander normally is assigned as staff weather officer to the army headquarters. The staff weather officer at each corps supervises all AWS activity within the division. In STRAC (United States Strategic Army Corps) units and missile commands, the senior AWS officer exercises command over all AWS personnel.

209. Manning

a. Charts 1 through 4 show example Air Weather Service organizations within the various echelons of a type field army.

	<i>Chart</i>
Air Weather Service Support of a Type Field Army -----	1
Army—Tactical Weather Station ..	2
Corps—Tactical Weather Station ..	3
Division—Tactical Weather Station .	4

b. The Air Weather Service support is functional and flexible and is capable of—

(1) Rapid revision to meet temporary changes in weather service requirements.

(2) More permanent revision to meet changing organizational and operational concepts of both the army and the Air Weather Service.

c. One specific change to the manning charts that may be expected in the near future is the addition of a radar weather section to the tactical weather station at field army or corps. This section may be organized when suitable weather radar becomes available.

Chart 1. Air Weather Service Support of a Type Field Army

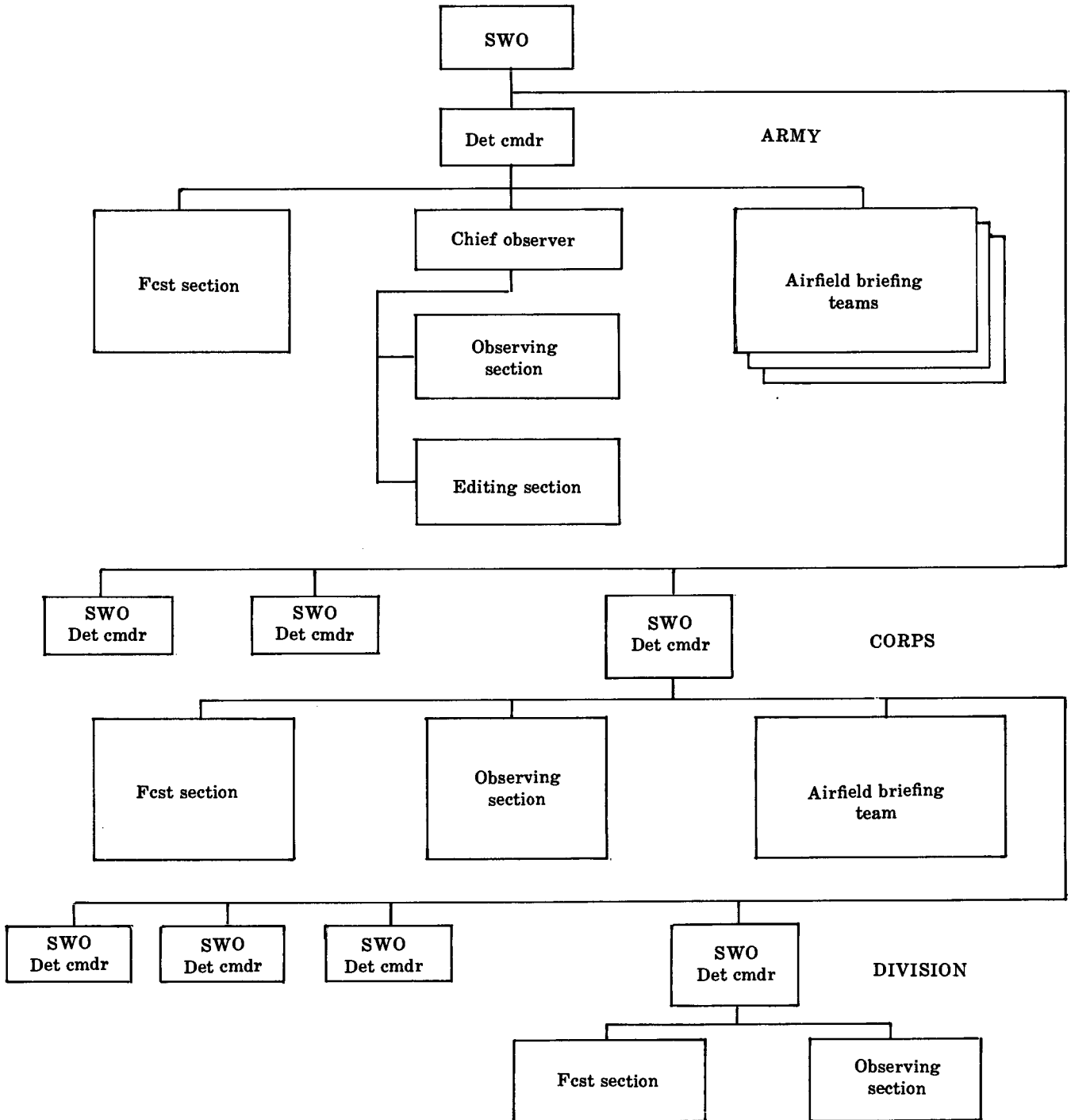

Chart 2. Army —Tactical Weather Station

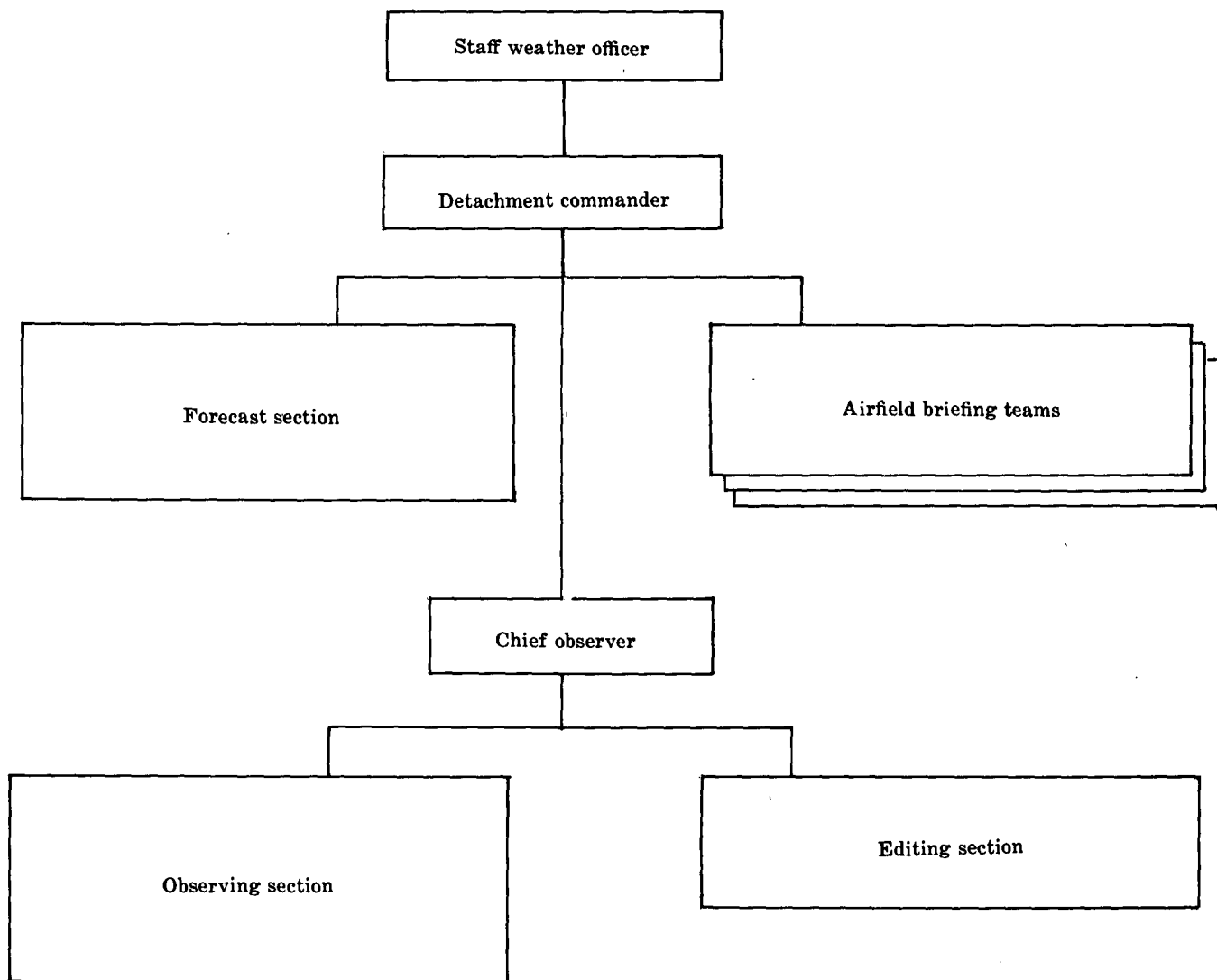

Chart 3. Corps—Tactical Weather Station

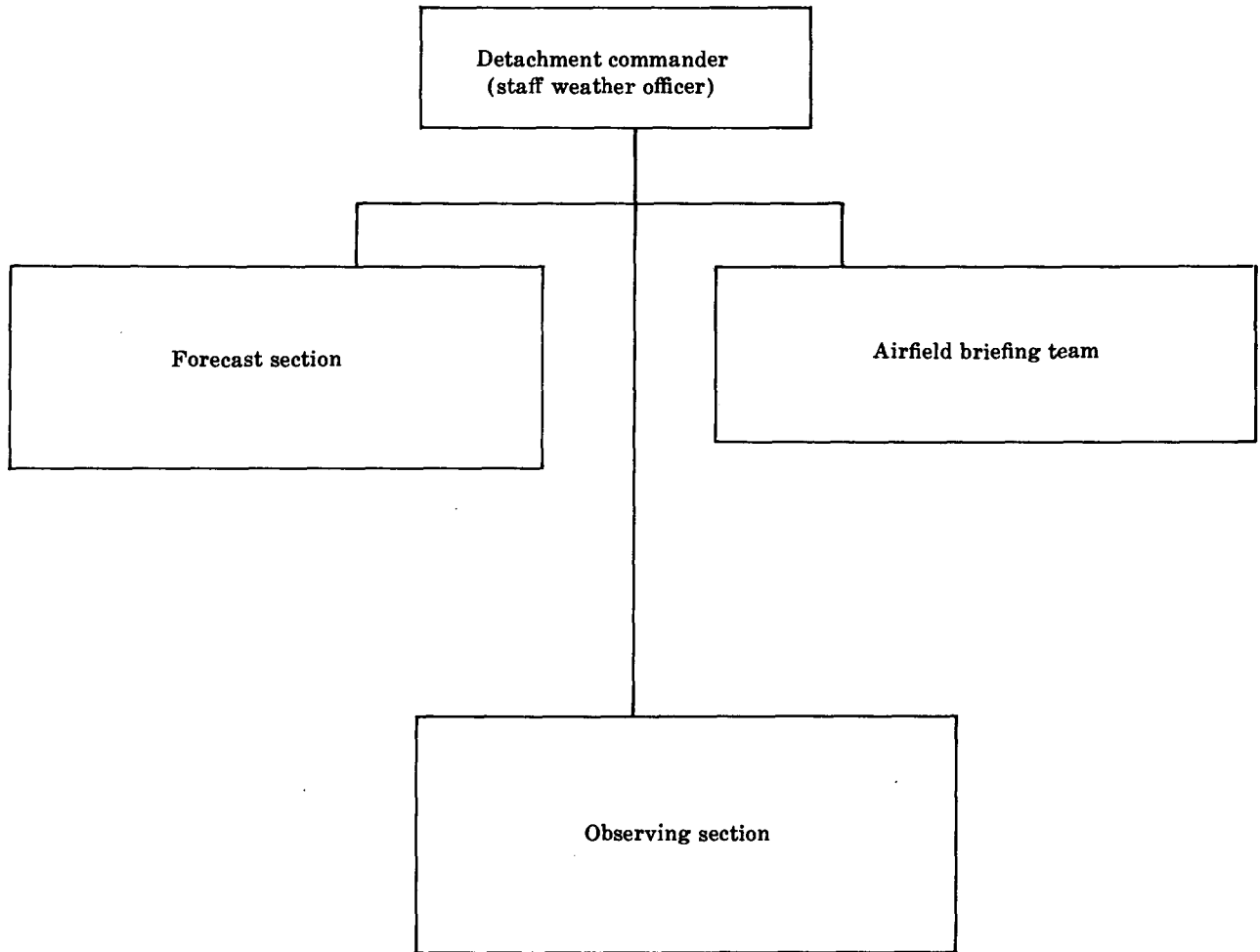
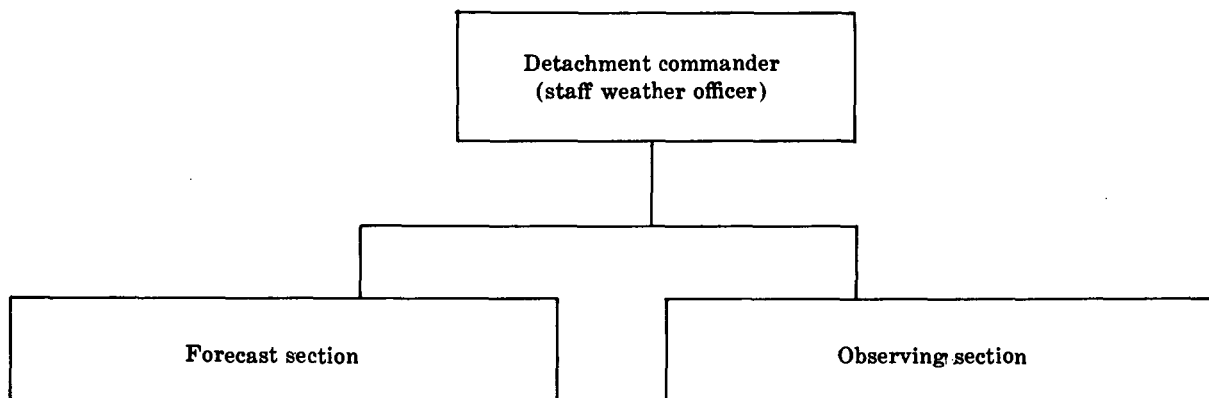

Chart 4. Division—Tactical Weather Station



CHAPTER 21

WEATHER FORECAST CAPABILITIES AND LIMITATIONS OF THE AIR WEATHER SERVICE

210. Worldwide Weather Service Data

The Air Weather Service operates on a global basis and has the mission of providing weather information for both the Army and the Air Force. The mission of the Air Weather Service includes both forecasting and climatological information. A wide variety of weather phenomena will be encountered by AWS personnel in performing their mission throughout the world; therefore, they have a continual need for both surface and upper air data. The necessary raw meteorological data to make a forecast must be furnished at specified intervals by hundreds of observing stations. Within the CONUS, there are relatively few fully equipped AWS stations, as the U.S. Weather Bureau has been assigned the responsibility of furnishing the bulk of the upper air data required by the other weather services. Overseas, the AWS has an increased capability for taking upper air observations; yet wherever possible, the weather service uses the data furnished by allied meteorological services. In tactical operations involving the Army, the AWS uses the data furnished by the artillery ballistic meteorological sections. A reliable forecast is dependent on an accurate description of the atmosphere over a large geographical region. In certain parts of the world where many land areas are inaccessible, data is secured by aerial reconnaissance flights; ships at sea provide data over ocean areas. Because of the temporary nature of weather information, a rapid and dependable means of acquiring and exchanging raw, analyzed, and forecast data must be available at all times. The volume of weather information traffic within a field army will vary with the composition and mission of the command. Communication means for weather information traffic is primarily in the form of radioteletype, continuous wave broadcasts, and radio facsimile. Adequate weather communications are a necessary prerequisite of satisfactory weather service.

211. Definitions

a. Weather Information—Information concern-

ing the condition and behavior of the atmosphere at a given place or over a given area and for a given instant of time or for any specified period of time.

b. Climatological Information—Information which deals with weather conditions and variations from normal for a particular place or area during a specified period of the year. Two types of climatological information are climatic summaries and climatic studies.

(1) *Climatic summary*—A statistical expression of weather elements in terms of averages, extremes, and frequencies of occurrences over a given period of time. This summary highlights those features of the climate which may impose problems in military operations and is of value to the field commander in preparing to meet such problems.

(2) *Climatic study*—The application of climatological information in a manner to reveal the probable effects of climate and weather elements on a specific operation or activity.

c. Weather Forecast—A prediction of expected weather conditions at a point, along a route, or within an area for a given time or specific period of time in the future.

(1) *Short period forecast*—Predictions up to 48 hours in advance.

(2) *Extended period forecast*—Predictions 3 to 5 days in advance.

(3) *Long period forecast*—Predictions for more than 5 days in advance. A statement of expected variations of weather elements from climatological normals.

d. Weather Summary—A description of the weather elements that have occurred at a point, along a route, or within an area during a specified period of time.

212. Forecast Available From AWS Detachments at Army, Corps, and Division Levels

a. General. The use of various weather elements from a forecast or a climatic summary will vary considerably between the levels of a com-

mand and even between units of the same level. Request for assistance or services beyond the capabilities of air weather service personnel at any echelon are forwarded to higher echelons. All weather detachments depend on the next higher echelon for backup data and forecast assistance. Therefore, when this backup assistance is not available because of the tactical situation, the quality of weather support will deteriorate.

b. Field Army. On the nuclear battlefield, the field army may exert influence throughout an area as large as 480 kilometers square. A command of this extent will have numerous requirements for weather information to insure effective employment of its forces. The weather detachment at army provides technical liaison with higher echelon weather agencies and provides planning guidance, coordination, and limited technical and logistical support for AWS detachments at lower echelons. This detachment furnishes daily forecasts for periods up to 48 hours, limited climatological information, flight forecasts, and facilities for editing observations made within the army area.

c. Corps and Division. The weather support required by corps and divisions differs from that required by an army because of the reduced area of operations and reduced planning time for operations. Corps and divisions require climatic information and extended period forecasts and, in addition, require current weather observations and short period forecasts.

213. Special Forecast and Climatology

a. In addition to the regular forecasts that are issued on a recurring basis, the Air Weather Service personnel are also responsible for special forecasts. One special forecast of considerable in-

terest to any commander is the severe weather forecast. Severe weather is defined as any type of weather or any value of a weather element which a commander considers a potential hazard to his equipment or personnel or the fulfillment of his mission. These special forecasts must be timely and accurate so that local precautionary measures may be taken to minimize property damage and personnel injuries. Weather stations at army level may be equipped with weather radar sets. These sets are capable of detecting and tracking thunderstorms and heavy precipitation areas within a radius of 160 kilometers of the station. Information concerning the location, shape, intensity, direction, and speed of severe weather movements can be determined and disseminated by the forecaster. A commander normally can plan on at least 2 hours notification of severe weather situations. In the future, a new radar set, capable of presenting a three-dimensional picture of storms within a 400-kilometer radius of the station, will replace the present weather radar.

b. The climatic summaries and studies are used to supplement the information contained in intelligence surveys. The summaries should be available to a commander at least 6 months prior to the period covered by the report. Certain items of information that describe a region may be required by staff members or the technical services in planning for a military operation. Examples of such requirements are the relation between precipitation, snow cover, and thaw dates used by the engineers when they prepare charts on soil trafficability. The wind and cloud patterns that may be expected at the surface and aloft during a certain season are needed by staff sections planning airborne operations.

CHAPTER 22

ENCODING AND EXCHANGE OF METEOROLOGICAL DATA
BETWEEN AIR WEATHER SERVICE AND ARMY ARTILLERY**214. Establishment of Liaison With Air Weather Service Detachments**

a. Many items of equipment and many methods employed by Air Weather Service (USAF) are identical to those in use by artillery met sections. In certain cases, the data obtained by an artillery met section will be of value to the weather forecaster. Similarly, data available from the Air Weather Service may assist the artillery met section in performing its mission. Therefore, information should be exchanged when practicable. Liaison for the exchange of weather information is directed by higher headquarters. However, the artillery met section should contact the nearest Air Weather Service installation as soon as possible after arrival in an area of operation. Personal liaison should be used to the maximum to work out the details of rapid transmission of data and to affirm the codes authorized for use.

b. Weather information may be exchanged by means of wire, radio, or messenger. The most expeditious means possible should be utilized. The manner of transmission of data is a detail which

should be worked out between the Air Weather Service installation and the artillery met section.

★215. Encoding Upper Air Meteorological Data for Exchange Between Army Artillery and Air Weather Service

Meteorological support of the field army requires that met data be exchanged between the army artillery met sections and the Air Weather Service detachments assigned to the field army. In order that this exchange may be accomplished routinely and efficiently, a coded message format, compatible with the two meteorological services and the communications means, is necessary. This paragraph specifies the standard code for use by artillery meteorological sections in support of an AWS unit.

a. *Upper Air Sounding Messages Format.* The data are encoded in five- and three-digit groups for convenience in radio teletypewriter transmission. The encoded message consists of three parts; the heading, the significant level data, and the rawin data. The present format is as follows:

Signifi-	Heading	METWQ	L ₀ L ₁ L ₂ GG	L ₀ L ₁ L ₂ gg	YYhhh	
cant	hhhhh	SSPPP	TTTUU	hhhhh	SSPPP	TTTUU
level	hhhhh	SSPPP	TTTUU	***	***	
data	66666	hhhhh	PPPTT	hhhhh	PPPTT	***
	Rawin	RAWIN	HHddd	fff	HHddd	fff
	data	HHddd	fff	HHddd	***	***

The data are recorded on DA Form 3583 (Meteorological Data for Artillery-Air Weather Service Exchange) (fig. 133). Rawin data are recorded on the back of the form (fig. 134).

b. *Heading.* The heading consists of four five-digit groups which identify the sounding station and the time of the balloon release.

(1) Group 1—METWQ.

METW—Transmitted to indicate that the message is encoded for exchange between Army artillery and the Air Weather Service.

Q—Is the number for the Q code for octant of the observing station. See table V for Q code.

Note. When using the Q code, latitude is always given first.

(a) When the Q code is 1, 2, 6, or 7, no value for longitude is encoded in more than three digits (99.9°). For a longitude equal to 100° or more, the first digit, 1, corresponding to 100, is dropped when encoding and added when decoding.

(b) When codes are used, meteorological stations will report coordinate location by geographic or UTM grid coordinates, as required. Code names for station locations are specified by appropriate standing signal instructions (SSI). Six-letter code words will be used. Number 9 of the Q code will be used when a station code name

METEOROLOGICAL DATA FOR ARTILLERY - AIR WEATHER SERVICE EXCHANGE									
For use of this form, see FM 6-15; the proponent agency is United States Continental Army Command.									
IDENTIFICATION METW	OCTANT Q	LOCATION LATITUDE (deg & tenths) LaLaLa	RELEASE TIME HR - GMT GG	LOCATION LONGITUDE (deg & tenths) LoLoLo	RELEASE TIME MIN - GMT gg	DATE Z YY	STATION HEIGHT (10's meters) hh		
METW	1	347	17	989	30	17	036		
SIGNIFICANT LEVEL DATA									
HGT MAN LVL hhhh	LEVEL NR SS	PRESSURE mb PPP	TEMPERATURE 1/10°C TTT	RELATIVE HUMIDITY % UU	HGT MAN LVL hhhh	LEVEL NR SS	PRESSURE mb PPP	TEMPERATURE 1/10°C TTT	RELATIVE HUMIDITY % UU
XXXX	00	967	294	40	XXXX		073	10	
XXXX	01	911	210	10	2060		050	12	
XXXX	02	862	145	10	XXXX		038	09	
0110	03	850	170	10	2380		030	11	
XXXX	04	822	230	10	XXXX		028	12	
XXXX	05	745	083	10	XXXX		021	04	
0274	06	700	083	10	XXXX		016	05	
XXXX	07	675	083	10	3092		010	96	
XXXX	08	630	037	33					
XXXX	09	610	013	10					
0543	10	500	607	10					
0700	11	400	727	10					
XXXX	12	373	762	10					
XXXX	13	XXX	XXX	XX					
0915	14	300	878	10					
XXXX	15	288	898	10					
	66	666							
1040		250	92						
1188		200	97						
1374		150	08						
XXXX		140	11						
XXXX		120	13						
XXXX		113	09						
1627		100	12						
<p>NOTE: Level numbers are numbered sequentially to the level where temperature is colder than -40°C. Then 66666 is transmitted to indicate that only a five-digit group will be transmitted for each level, 3 digits for pressure and 2 digits for temperature see Ch22, FM 6-15.</p>									

DA FORM 3583
1 MAR 70

REPLACES DA FORM 6-60, 1 MAR 62, WHICH IS OBSOLETE.

★Figure 138. Meteorological data recorded for Air Weather Service message.

is used or when the location is given by UTM grid coordinates. When military grid coordinates are used to identify the station location, $L_n L_n L_n$ will be the X coordinate and $L_o L_o L_o$ the Y coordinate to the nearest 1,000 meters.

(2) *Group 2*— $L_n L_n L_n G G$.

$L_n L_n L_n$ —The latitude of the observing station to the nearest 0.1°.

$G G$ —The hour (GMT) during which the sounding balloon was released. This may be any number from 00 through 23.

(3) *Group 3*— $L_o L_o L_o g g$.

$L_o L_o L_o$ —The longitude of the observing station to the nearest 0.1°.

$g g$ —The number of minutes past the hour at which the balloon was released. This may be any number from 00 through 59.

(4) *Group 4*— $Y Y h h h$.

$Y Y$ —The day of the month of the observation. This may be any number from 01 through 31.

$h h h$ —The altitude of the observing station to the nearest 10 meters. Altitudes below sea level are indicated by transmitting a 9 for the first digit. For example, an altitude of -30 meters would be transmitted as 903.

c. Significant Level Data. Data for each mandatory and significant level are encoded in 5-digit groups. Because humidity is not computed below -40° C. (normally at pressures around 200 mb) the significant level code is reduced to two five-digit groups when temperatures below -40° C. are reached ((2) and (3) below). Levels are selected on the radiosonde recorder record according to criteria set forth in chapter 7.

(1) *Significant Level*— $h h h h h S S P P T T T U U$.

(a) $h h h h h$ —Heights of mandatory levels in tens of meters, to the nearest ten meters.

(b) $S S$ —The number of the significant level. The first significant level is the surface level numbered 00. Levels are numbered consecutively from the surface up.

(c) $P P P$ —The significant level pressure in millibars. For encoding pressures greater than 999 millibars, the first

digit, 1, corresponding to 1,000 is dropped.

(d) $T T T$ —The significant level temperature to the nearest 0.1° C. encoded as follows: Temperatures of 0° C. and warmer are reported directly; for temperatures of -0.1° C. through -49.9° C., the minus sign is disregarded and 50 is added; for temperatures of -50.0° C. or below, the minus sign is disregarded and 50 is subtracted. For example, 6.2° C. is encoded 062, -8.7° C. is encoded 587, and -59.2° C. is encoded 092.

(e) $U U$ —The significant level relative humidity reported in whole percent. One hundred percent relative humidity is encoded 00.

(2) *Indicator Group*—66666.

66666—Transmitted as an indicator that the significant level will be coded in two five-digit groups and that neither level numbers, relative humidity values, nor tenths values of temperatures are reported for subsequent levels. The group 66666 further indicates that significant level temperatures are colder than -40° C.

(3) *Significant Level*— $h h h h h P P P T T$.

$h h h h h$ —Heights of mandatory levels.

$P P P$ —The significant level pressure in millibars.

$T T$ —The significant level temperature, encoded as explained in (1) (d) above, but reported to the nearest whole degree Celsius. For example, -53.2° C. would be encoded 03 (53.2 - 50 = 03.2).

d. Rawin Data. Rawin data are the wind directions and speeds at standard heights above the observing station (fig. 134). The code numbers of the standard heights are shown in table 6. The heights shown are the zone midpoint heights. The zone structure is the same as the zone structure for computer message winds and, to line 26, are the same winds as those prepared for a computer message (para 146 and 147). Above 20,000 meters, lines 27-31, winds are the same as fallout zone winds.

Table 6. Wind Height Code

HH code	Height (meters)	HH code	Height (meters)
00	Surface (MDP)	17	10500
01	100	18	11500
02	350	19	12500
03	750	20	13500
04	1250	21	14500
05	1750	22	15500
06	2250	23	16500
07	2750	24	17500
08	3250	25	18500
09	3750	26	19500
10	4250	27	21000
11	4750	28	23000
12	5500	29	25000
13	6500	30	27000
14	7500	31	29000
15	8500		
16	9500		

(1) *Indicator group*—RAWIN. RAWIN is transmitted to indicate that wind data will follow.

(2) *Wind groups*—HH ddd fff.

HH—The code for the height. This may be any number from 00 (surface) through 31. See table 6.

ddd—The wind direction to the nearest degree from geographic (true) north.

fff—The wind speed to the nearest knot.

★216. Determination of Height of Mandatory Pressure Levels

The procedure for determining the heights of the mandatory pressure levels is similar to that used in determining the height of the tropopause (para 198). The following steps are taken—

a. On chart ML-574/UM the heights of the mandatory pressure level above the preceding artillery zones is measured with the height scale in meters on scale ML-573.

b. The height measured is added to the height of the preceding artillery zone.

c. The height for each mandatory pressure level is reported in tens of meters to the nearest ten meters.

★217. General Rules for Encoding Data

a. All data reported are relative to the altitude of the artillery observing station (the met datum plane).

b. Missing data are encoded as X's.

c. The critical angle for wind data is 6°. This

6° angle is measured vertically above and/or horizontally from any terrestrial object. No wind data will be reported when the observed angles are smaller than the critical angle of 6°.

★218. Artillery Met Applications of a Message From Air Weather Service (AWS)

When Army artillery met sections do not have the capability of making upper air soundings, they will request upper air data from the Air Weather Service. Data will be furnished in appropriate DA Form 3583 code. Artillery or fallout met messages prepared from AWS data will show the same octant location as the AWS message. When local SOP's require the use of a coded location, the code of the artillery met section will be used. Date, time, and MDP will be the same as the AWS message.

★219. Computation of Artillery Zone Temperature and Density

a. Surface temperature, density, and station pressure as a percent of standard will be computed using the 00 line data of the significant level portion of the AWS message (fig. 135).

b. The upper air sounding will be plotted on chart ML-574/UM using the significant level data from the AWS message (fig. 135). The plotting procedures, the measurement of zones, and the determination of zone and ballistic values of temperature and density are the same as described in chapter 7.

★220. Computation of Zone Winds

The RAWIN portion of the AWS message is the midzone vector wind for the computer message zone structure. When a requirement for computer message winds exists, the RAWIN portions of the AWS message may be used after converting wind directions to mils.

a. When a NATO or fallout message is to be developed, appropriate zone winds must be computed using the RAWIN portion of the AWS message. The computation is done graphically on plotting board ML-122 using scale ML-577. In one case, as many as five AWS RAWIN winds must be plotted in order to produce a fallout zone wind and in other cases, the AWS RAWIN wind is used directly.

b. It is assumed that the vector winds of the AWS message are the average winds for the related zone. When computing NATO or fallout zone winds, it is necessary to take into account the relative thickness of the zones. In most cases

RAWIN DATA							
STANDARD HEIGHT (Meters)	HEIGHT CODE HH	WIND DIRECTION (Degrees) ddd	WIND SPEED (Knots) fff	STANDARD HEIGHT (Meters)	HEIGHT CODE HH	WIND DIRECTION (Degrees) ddd	WIND SPEED (Knots) fff
RAWIN				9500	16	222	016
SUR	00	174	004	10500	17	216	014
100	01	141	013	11500	18	213	028
350	02	172	014	12500	19	222	021
750	03	201	014	13500	20	238	017
1250	04	223	007	14500	21	352	016
1750	05	282	008	15500	22	002	019
2250	06	255	015	16500	23	357	025
2750	07	267	013	17500	24	042	023
3250	08	292	013	18500	25	060	026
3750	09	327	018	19500	26	088	029
4250	10	323	017	21000	27	094	021
4750	11	318	016	23000	28	098	028
5500	12	321	015	25000	29	094	026
6500	13	331	009	27000	30	086	038
7500	14	344	011	29000	31	094	051
8500	15	199	012				
Delivered to: <i>SWO</i>				Remarks:			
Received from: <i>3d Div Arty</i>							
Date: <i>3 MAY 69</i>		Time: <i>1912</i>		Flight number: <i>3</i>			
Recorder: <i>Langston</i>				Checker: <i>Bany</i>			

Figure 184. Rawin data recorded on back of AWS metro message form.

SURFACE OBSERVATIONS MESSAGE FOR AWS

For use of this form, see FM 6-15; the proponent agency is United States Continental Army Command.

LOCATION	OBSERVATION TIME (GMT)	WIND DATA			PREVAILING VISIBILITY (meters)	PRESENT WEATHER (code)	CLOUD DATA (Repeat as necessary)			TEMP DATA		STATION PRESSURE (mbs and tenths)	REMARKS AND SUPPLEMENTAL INFORMATION
		DIRECTION (nearest 10 degrees)	AVG SPEED (knots)	MAX SPEED (knots)			AMOUNT (eighths)	TYPE (code)	HEIGHT (100's of feet)	AIR (°C)	DEW POINT (°C)		
(1)	(2)	(3a)	(3b)	(3c)	(4)	(5)	(6a)	(6b)	(6c)	(7a)	(7b)	(8)	(9)
AC 23	0059 Z	140	03		9999		2	CS	240	09	06	QFE 1001.3	(FRM)
AC 23	0156 Z	000	00		8500	4LFGHZ	2	AC	110	07	05	QFE 1000.0	DSNT LTNG NE (FRM)
AC 23	0255 Z	160	02		0800	510Z	9	//	01	06	06	QFE 1000.2	VSBY 5-5W 0400 (FRM)
AC 23	0358 Z	170	06	11	7000	42FG	1	CB	15	04	02	QFE 1000.6	CB NW MOVG SE (CBW)
AC 23	0459 Z	290	23	40	0400	99XZTS	9	//	00	04	01	QFE 1001.0	HLSTO 13/4 INS (TAS)
AC 23	0556 Z	140	09		9999	94XXGR	2	CB	15	04	00	QFE 1001.3	CB SE MOVG SE (TAS)
AC 23	0657 Z	340	10	15	9999	83RASN	3	CU	25	03	00	QFE 1001.8	DSNT LTNG SE (CBW)
AC 23	0756 Z	360	12	21	8000	85SNSH	8	SC	40	01	MO4	QFE 1002.4	(FRM)
AC 23	0859 Z	350	10		9999		2	SC	35	MO2	MO7	QFE 1003.4	SINW DEP 2 INS (FRM)
AC 23							3	AC	80			QFE	

REMARKS:

PERIOD COVERED: FROM: 0100Z/13 MAR 70 TO: 0900Z/13 MAR 70

DA FORM 1, JAN 71, 3678

★ Figure 185. AWS message-radiosonde data.

THE SURFACE OBSERVATION MESSAGE FOR AWS IS ENCODED AS FOLLOWS

Group	Explanation	Group	Explanation
1	Location. Enter some mutually accepted means of identifying the observation station and location; e.g., latitude and longitude in degrees and minutes or a station identifier.		
2	Observation time. Enter the time the last element of the observation was observed to the nearest minute (GMT).		
3	Wind Data: a. Direction. Enter the direction from which the wind is blowing in degrees true north, to the nearest 10 degrees, using three digits; e.g., 287° as 290°, 73° as 070° etc. Enter variable direction as "999". When wind is calm enter "000" for direction. A ten minute average is desirable. b. Speed. Enter wind speed to the nearest whole knot using at least two digits. When the wind is calm, enter "00" for speed. Wind speeds of 100 knots or greater will be entered in three digits. c. Maximum Wind Speed. Enter to the nearest whole knot, in two digits (three digits when 100 knots or more). Enter only when the maximum wind speed exceeds the prevailing wind speed by five knots or more.		
4	Prevailing Visibility. Enter in meters using the reportable values in table Va of FM 6-16. Enter "9999" when the prevailing visibility is greater than six statute miles. When visibility is halfway between two reportable values, enter the lower numerical value.		
5	Present Weather. Enter the appropriate code, numbers and letters, in chart XIII.2 of FM 6-16. Note that two or more codes should be entered when there is no code to express a combination of phenomena occurring at the same time; e.g., a. For continuous drizzle of light intensity occurring with fog which is becoming thicker and in which the sky and/or clouds above are visible, enter both 51DZ and 46FG. b. For continuous rain and snow of light intensity occurring together, the combination code "68RASN" can be used.		
6	Cloud Data: a. Amount of Sky Cover. Enter the amount of sky obscured by the individual layer, in eighths; e.g., enter "4" for half the sky covered by cloud layer, "8" for a total overcast, etc. Enter "9" to indicate the sky and/or clouds are completely hidden by a surface based obscuring phenomena such as fog or by precipitation (i.e., a "totally obscured" sky condition).		
		7	Temperature Data: a. Air Temperature. Enter to the nearest whole degree Celsius. Precede each negative value with the letter "M"; e.g., -40C = M04, -39C = M39 etc. b. Dew Point Temperature. Enter to the nearest whole degree Celsius. Precede each negative value with the letter "M" as above.
		8	Station Pressure. Enter station pressure to the nearest tenth of a millibar to include the decimal. Always precede the value with "QFE".
		9	Remarks. Enter any remarks and supplemental information considered necessary to amplify preceding coded data or to provide additional data, such as precipitation amounts, snow depth, surface trafficability, sector visibilities which differ from the prevailing visibility, etc.
			Notes: (1) Enter all layers and enter in the ascending order or height; e.g., 4 SC 43 1 AC 100 1 CS 270. (2) Do not enter a group for a surface based obscuring phenomena such as fog or precipitation which hides less than 8/8 sky. However, a group may be added in remarks (column 9) to describe the condition; e.g., 6 FG / / for 6/8 fog and cloud type above unknown, 2 RA / / for 2/8 rain and cloud type above unknown, etc. (3) Make no entry for group 6a thru 6c when sky is "clear".

★ Figure 135—Continued.

only two zones of equal thickness are averaged.

c. To average two zone winds of equal thickness, first multiply the two zone wind speeds by 0.5 to give them equal weight and then make a vector (using ballistic wind plotting technique) of the lower zone wind and add to it the upper zone wind. The resultant vector plot is the average wind speed and direction (fig. 136).

d. In the instance of fallout zone 01 wind, AWS heights 01 through 05 must be averaged (fig. 137). Before plotting, the AWS winds are weighted, due to zone structure, as follows:

Windspeed of AWS height	Multiply speeds by
01 -----	0.10
02 -----	0.15
03 -----	0.25
04 -----	0.25
05 -----	0.25
Total -----	1.00

Figure 136. Average vector wind plot.

(Located in back of manual)

The AWS weighted wind 01 is plotted, weighted wind 02 is added to 01, weighted wind 03 is added to 02, weighted wind 04 is added to 03, and weighted wind 05 is added to 04 plot. The five AWS weighted winds are plotted and the resulting vector is measured to determine the zone wind speed and direction for fallout zone 1.

e. Table 7 shows the relation between AWS RAWIN zone winds to NATO and fallout zone structure and the weighting factors to be applied to AWS RAWIN zone winds.

f. In the case of a NATO message, the resulting zone vectors will be the zone winds. Ballistic winds must be plotted as in chapter 7.

Figure 137. Averaging fallout zone winds for AWS heights.

(Located in back of manual)

★221. Encoding Surface Observations Meteorological Data for Use by the Air Weather Service

Air Weather Service detachments with the field army are not manned or equipped to provide the detail of surface observations coverage required for accurate subsynoptic forecasts within the field army area. In recognition of this problem, Department of the Army has agreed that Artillery Meteorological Sections will provide surface observation information to AWS elements on a routine and regular basis (para 214 applies).

a. *Message Format.* The data are encoded in a

standard sequence to provide for convenient transmission by voice communications means. However, the format can be adapted for use with other communications means through coordination between the Air Weather Service installation and the Artillery met section concerned.

b. *Encoding of Data.* Surface observations data are encoded on DA Form 3678 (fig. 135). Use of this form is described on the back of the form (fig. 135). The data recorded on the form are encoded as follows:

(1) *Location.* A mutually acceptable means of identifying the observation station and location; e.g., latitude and longitude or a station identifier.

(2) *Observation time.* The time, to the nearest minute, that the last element of the observation was observed.

(3) *Wind data.*

(a) *Direction.* The direction from which the wind is blowing, in degrees reference true north, to the nearest ten degrees, using three digits. When wind direction is variable, enter 999; when wind is calm, enter 000 in the block.

(b) *Speed.* Wind speed, to the nearest whole knot, in at least two digits. When the wind is calm, enter 00.

(c) *Maximum wind speed.* Wind speed value, to the nearest whole knot, when the value exceeds the prevailing wind speed by 5 knots or more.

(4) *Prevailing visibility.* Visibility in meters, using the reportable values in table Va, FM 6-16.

(5) *Present weather code.* Number/letter combinations, shown in Chart XIII.2, FM 6-16, which describes the current weather phenomena.

(6) *Cloud data.*

(a) *Amount of sky cover.* The amount of sky obscured by the individual layer, in eighths. The figure "9" is used to indicate that the sky and/or clouds are completely hidden by a surface based obscuring phenomena such as fog.

(b) *Type(s) of cloud(s).* Abbreviation(s) for the cloud type(s) composing the layer, using the contractions shown in table Vb, FM 6-16. Only the predominant type of cloud for the layer is recorded, except when cumulonimbus (CB) is present and not predominant. In that case, an entry is made for each of the cloud types. Two slant strokes "/" are used to indicate a totally obscured sky condition.

(c) *Height of layer.* The height of the cloud layer, in hundreds of feet in at least two

digits (three digits for 10,000 feet and above). When the height is halfway between two reportable values, enter the lower numerical value.

Note 1: Enter all layers and enter in the ascending order of height.

Note 2: Do not enter a group for a surface based obscuring phenomena which hides $\frac{7}{8}$ or less of the sky. However, a group may be added in Remarks (column 9) to describe the condition.

Note 3: When the sky is "clear," no entry is made in the "Cloud Data" column.

(7) *Temperature data.*

(a) *Air temperature.* The ambient air temperature rounded to the nearest whole degree Celsius. Negative temperature values are preceded by the letter "M"; e.g., -4° C. = M04.

(b) *Dew point temperature.* The dew point temperature rounded off to the nearest whole degree Celsius. Negative temperature values are preceded by the letter "M"; e.g., -39° C. = M39. Chart XIII.1, FM 6-16 is utilized in determining the dew point temperature.

(8) *Station pressure.* Pressure at the met datum plane, recorded to the nearest 1/10th millibar.

(9) *Remarks.* Any remarks and/or supplemental information considered necessary to amplify or clarify the preceding coded data. Additional data, such as precipitation amounts, snow depths, etc., may also be recorded in this space.

Table 7. Composition of Zone Wind Structures.

For NATO zone number	Use AWS RAWIN heights	Multiply AWS RAWIN height speed by	For fallout zone number	Use AWS RAWIN heights	Multiply AWS RAWIN height speed by
SURF	00 (Surf)	1.0	SURF	00 (Surf)	1.0
01	01	1.0	01	01	0.10
02	02	1.0		02	0.15
03	03	1.0		03	0.25
04	04	1.0		04	0.25
05	05	1.0		05	0.25
06	06	0.5	02	06	0.25
	07	0.5		07	0.25
07	08	0.5		08	0.25
	09	0.5		09	0.25
08	10	0.5	03	10	0.25
	11	0.5		11	0.25
09	12	1.0		12	0.50
10	13	0.5	04	13	0.5
	14	0.5		14	0.5
11	15	0.5	05	15	0.5
	16	0.5		16	0.5
12	17	0.5	06	17	0.5
	18	0.5		18	0.5
13	19	0.5	07	19	0.5
	20	0.5		20	0.5
14	21	0.5	08	21	0.5
	22	0.5		22	0.5
15	23	0.5	09	23	0.5
	24	0.5		24	0.5
			10	25	0.5
				26	0.5
			11	27	1.0
			12	28	1.0
			13	29	1.0
			14	30	1.0
			15	31	1.0

PART SIX

SPECIAL APPLICATIONS AND MISCELLANEOUS OPERATIONS

CHAPTER 23

MEASUREMENT OF LOW-LEVEL WINDS FOR FREE ROCKETS

222. General

Winds have two major effects on the flight of a free rocket. One effect is the ballistic wind effect, and the other is the low-level wind effect. The ballistic wind effect is dominant only after burn-out of the rocket when the rocket is in a true ballistic flight. The ballistic wind effect on a free rocket is the same as that on an artillery projectile. The low-level winds are those winds encountered by the rocket during its powered flight, that short period of time between firing and burnout. For the Honest John rocket, this time is approximately 4 seconds. The low-level winds turn or cock the rocket into the wind (fig 138). This turning causes the thrust vector of the rocket to change and results in the rocket deviating from the intended path of flight. Corrections to rocket trajectories for ballistic winds are made in the same manner as corrections for artillery trajectories and are described in paragraph 24. The measurements of low-level winds and the corrections therefrom are made by launcher crew personnel at the launcher position just prior to firing. Low-level winds are continuously changing; therefore, time is of primary importance in measuring low-level winds and applying the corrections. The various methods of measuring the low-level winds are described in paragraphs 223 and 224. Application of corrections is described in the appropriate firing tables.

223. Aerovane Anemometers

a. The accurate measurement of a representative low-level wind is a difficult problem which has not been completely solved. A practical, method of measurement is by means of an Aerovane anemometer exposed 15 meters above the surface. The equipment currently issued for making this measurement is wind measuring set (windset) AN/MMQ-1() (fig 139) or AN/PMQ-6 (fig 140). These wind measuring sets are described in TM 11-6660-203-10. The essen-

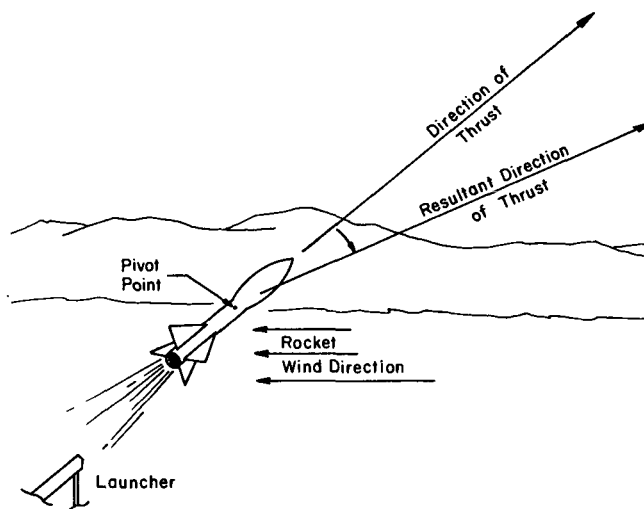

Figure 138. Low-level wind effect on rocket.

tial components of the sets are a telescoping mast (15 meters), a wind transmitter, and an indicator. The indicator is positioned remotely from the mast and usually at the fire control point from which the rocket is fired. Indicator ID-624() reads out range and cross wind corrections in miles per hour. The anemometer (fig 141) is activated by a six-blade impeller, which reacts to a wind speed greater than 2 or 3 knots. As the impeller rotates, it turns the armature of a small generator, which develops a voltage proportional to the wind speed. The voltage generated is applied across a sinecosine potentiometer from which two outputs are taken. One, the cosine output, is a voltage proportional to the range wind, that wind component parallel to the direction of the launcher. The other is the sine output, which is a voltage proportional to the cross wind, that wind component perpendicular to the direction of fire.

b. The wind measuring set is emplaced in an open area away from any obstructions that would

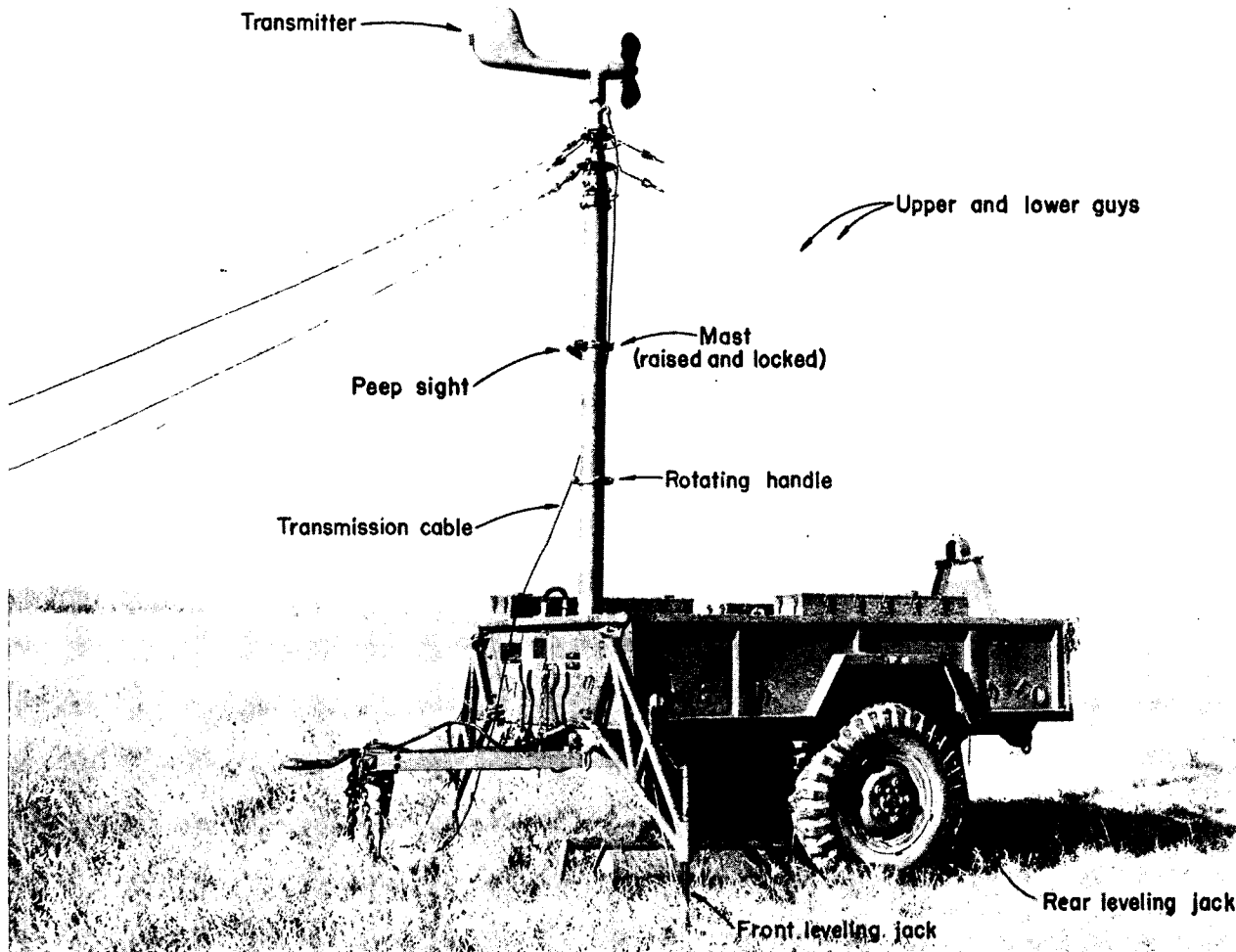

Figure 189. Wind measuring set
AN/MMQ-1().

interrupt the existing wind pattern. The set should be emplaced approximately 50 meters in front of the rocket launcher and for safety at least 25 meters to the side of the trajectory. The mast initially should be oriented parallel to the azimuth of fire. If the deflection correction (met and rotation) exceeds 25 mils, the mast should be reoriented to the corrected firing azimuth before correction for low-level winds are determined. The measurement must be corrected to account for the fact that wind speeds generally increase with height and for the fact that the wind used for corrections should be the mean wind encountered by the rocket from the surface to the height of burnout. Hence, wind measuring set readings must be corrected by weighting, to account for height of burnout and wind speed variance. The correction factors for the 762-mm rocket (Honest John) are described in appropriate firing tables.

c. After a low-level wind has been measured and corrected, the launcher crew must apply the corrections to the settings on the launcher. The computation and setting of corrections requires about 2 minutes. Because of the fluctuations of low-level winds, it is probable that the value of the measured wind will change by the time of firing. Two techniques may be used to overcome this deficiency. One system is the recurring wind technique, wherein a wind measurement is made and the rocket is fired when the same wind recurs within a tolerance of plus or minus 1 knot. The other system is the technique of predicting wind, wherein the measured wind is averaged for 5 minutes and it is assumed that the average wind will persist until the rocket is fired. The recurring wind technique will produce the most valid low-level wind corrections but this technique cannot be used if the rocket is to be fired at a specific in-

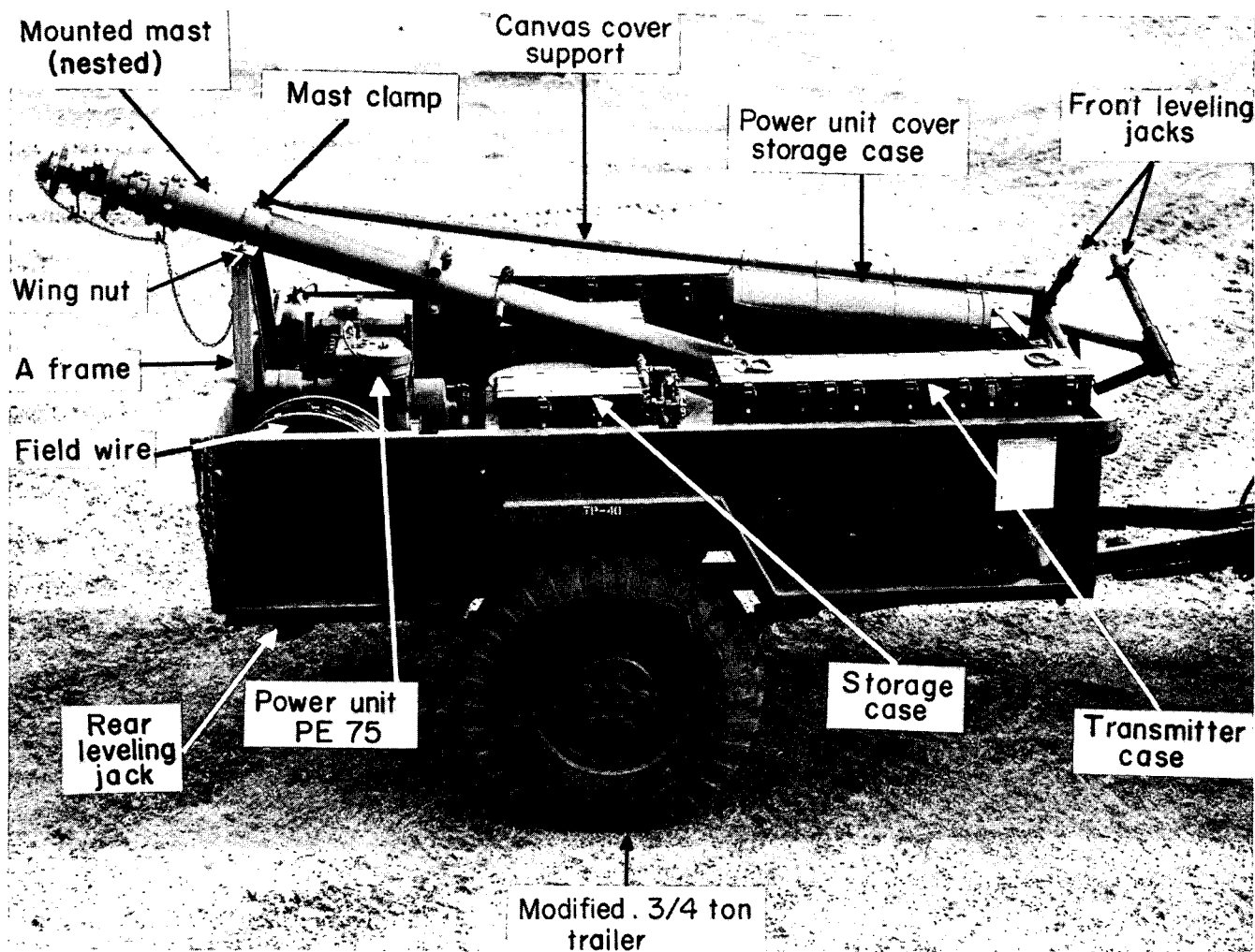

Figure 139—Continued.

stant, since the measured wind may not occur again at the time required to fire. For detailed information on application of wind corrections, see FM 6-40-1.

224. Pilot Balloon Observation for Measurement of Low-Level Winds

a. Low-level winds may be measured by means of a single theodolite observation of a pilot balloon. Because of the erratic rate of rise of a pilot balloon, the wind computed from a single theodolite observation is not as valid as a measurement with a wind measuring set. The single theodolite-balloon technique may be used as an alternate method. For this measurement, a theodolite is set up and oriented near the launcher, preferably upwind at a distance of approximately 50 meters. The distance is not critical. Installation and use of

the theodolite are described in paragraph 53. *The theodolite must be oriented so that the zero direction of the theodolite is in the direction of fire and not in the direction of true north.* This orientation may be accomplished by one of the three methods outlined below.

(1) *Panoramic telescope method.* The panoramic telescope is the optical instrument used to lay the launcher for direction. After the launcher has been laid, the following procedure may be used:

(a) Set up and level the theodolite.

(b) Obtain the deflection angle to the theodolite from the launcher by commanding DEFLECTION ANGLE, MET THEODOLITE.

(c) When facing the direction of fire, if the launcher is left of the theodolite, add 3,200 mils to the deflection angle. If the launcher is right of the theodolite, use deflection angle directly.

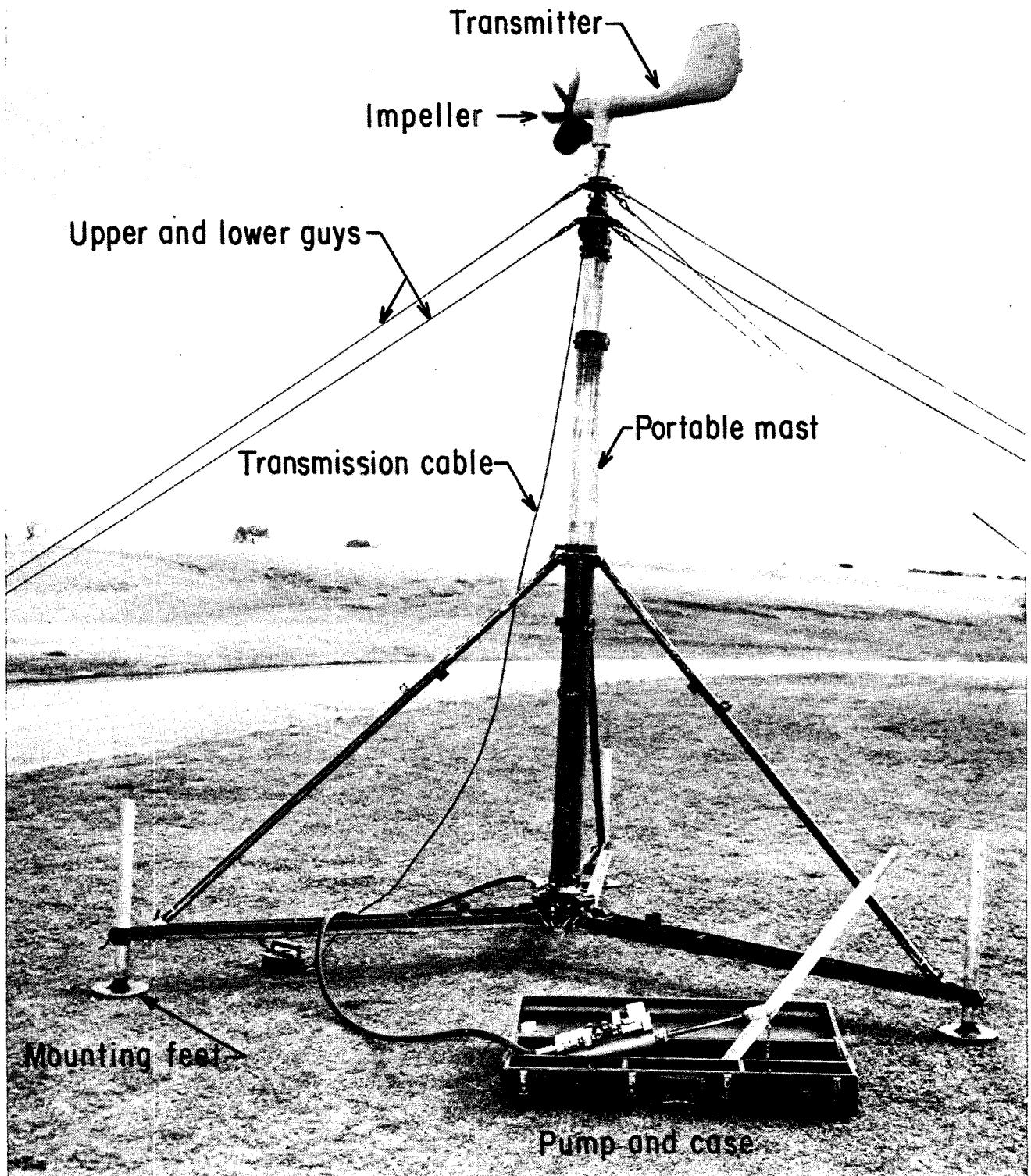

Figure 140. Wind measuring set AN/PMQ-6.

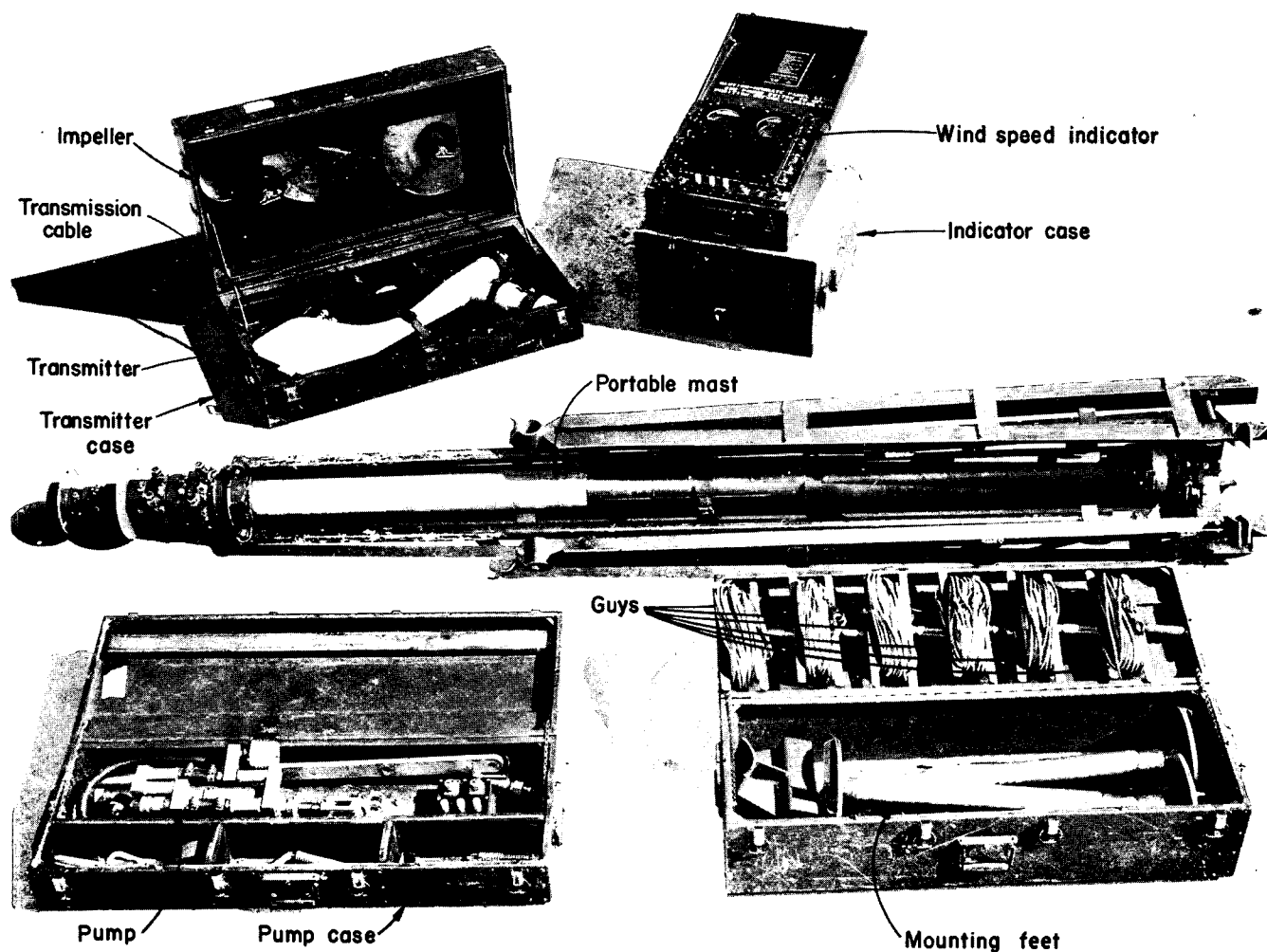

Figure 140—Continued.

Note. If the panoramic telescope has a 0-6,400 mil scale, subtract 3,200 mils when the launcher is right of the theodolite.

(d) Convert the deflection angle to degrees and set it on the azimuth scale. Engage the azimuth tracking controls.

(e) Loosen the azimuth calibration clamp on the theodolite.

(f) Sight the theodolite on the panoramic telescope. Tighten the azimuth calibration clamp. Adjust precisely. The theodolite is now oriented.

(2) *Orienting angle method.* The orienting angle method requires that the unit survey crew establish an orienting line in the firing position parallel to the launcher orienting line with a stake for the location of the theodolite and an identification of a distant aiming point of known direction. The following procedure is used:

(a) Set up and level the theodolite over the stake.

(b) Obtain the orienting angle from the launcher platoon leader and convert the orienting angle to degrees and tenths of degrees.

(c) Disengage the azimuth tracking control on the theodolite and set the orienting angle on the azimuth scale.

(d) Engage the azimuth tracking control and loosen the azimuth calibration clamp.

(e) Orient the theodolite approximately by sighting on the distant aiming point, using the fast motion.

(f) Tighten the azimuth calibration clamp and precisely orient the theodolite by using the azimuth calibration adjust. The theodolite is now oriented.

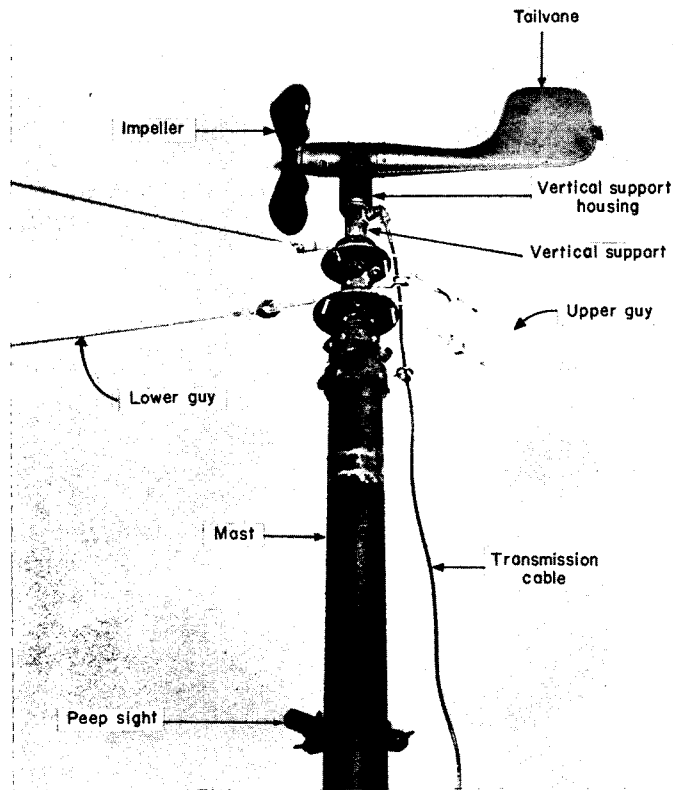

Figure 141. Anemometer.

(3) *Compass method.* When the launcher is laid by the compass method, the following procedure is used:

(a) Obtain the azimuth of fire from the launcher platoon leader. Convert the direction to degrees and tenths of degrees.

(b) Subtract the direction of fire from 36° and then apply the correction for the declination constant. The value of the declination constant may be obtained from a map of the local area. An east declination is added, and a west declination is subtracted.

(c) Disengage the azimuth tracking control and set the angle computed in (b) above on the azimuth scale of the theodolite. Subtract 360° if necessary.

(d) Engage the azimuth tracking control and loosen the azimuth calibration clamp.

(e) Lower the lifter level on the theodolite compass and allow the magnetic needle to rotate freely on its axis.

(f) Center the compass needle by means of the nonrecording motion of the theodolite.

(g) Tighten the azimuth calibration clamp. The theodolite is now oriented.

b. The wind measurement is made by means of single observation of a 30-gram balloon. For inflation and release of a 30-gram pilot balloon, see paragraphs 58 and 63. A single observation of the balloon is read at a time dependent on the quadrant elevation setting of the rocket launcher and the predicted wind profile. A prediction of the wind profile is simplified to "nighttime" conditions and "other than nighttime" conditions. The quadrant elevation-time of observation relationship is dependent on the configuration of the rocket. This relationship for the Honest John rocket is shown in the appropriate firing tables.

c. The procedure for measuring the wind is as follows:

(1) From the launcher crew, obtain the time of observation.

(2) Release the balloon 5 minutes prior to firing (X-5) and track the balloon with the theodolite.

(3) Read and record the vertical and azimuth angles of the balloon at the time obtained in (1) above.

(4) To determine the effective rocket wind speed in knots, use the vertical angle recorded to enter Table Ic, FM 6-16, Wind Speed for Zone 1 (Knots), 54-Second Reading, 30-Gram Balloon. This wind speed is the effective wind for the rocket and is not the mean wind for zone 1. Use chart XI, FM 6-16, to convert knots to miles per hour.

(5) To compute the component wind corrections for the rocket, multiply the effective rocket wind speed by the sine value of the balloon azimuth angle to obtain the range wind component and by the cosine value of the balloon azimuth angle to obtain the cross wind component. Use the slide rule. For example, range wind component = effective wind \times sine of azimuth; cross wind component = effective wind \times cosine of azimuth. The range wind could be either a headwind or a tailwind depending on the azimuth of the wind. Likewise, the cross wind could be either right or left. By using a wind compass (fig 142), the sense of the component values may be determined so that the corrections may be applied in the same manner as those for the reading from wind measuring set AN/MMQ-1 ().

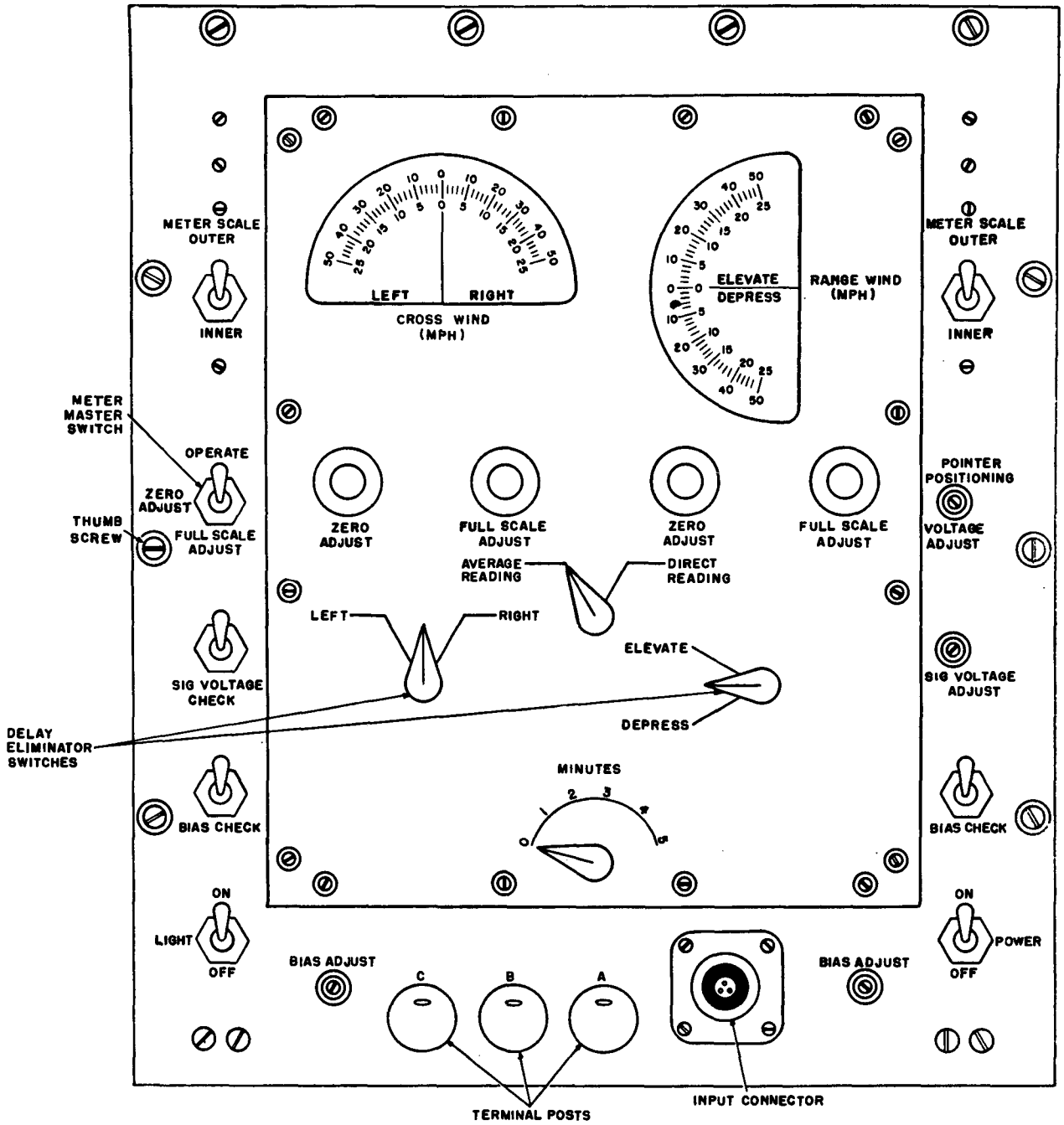

NOTE:
 ON SOME MODELS OF THE INDICATOR THE **RANGE WIND (MPH)** METER IS MARKED **HEADWIND** **TAILWIND** INSTEAD OF **ELEVATE** **DEPRESS** THE RIGHT-HAND DELAY ELIMINATOR SWITCH IS MARKED **HEADWIND** INSTEAD OF **ELEVATE** AND **TAILWIND** INSTEAD OF **DEPRESS**

WIND INDICATOR PANEL

Figure 141—Continued.

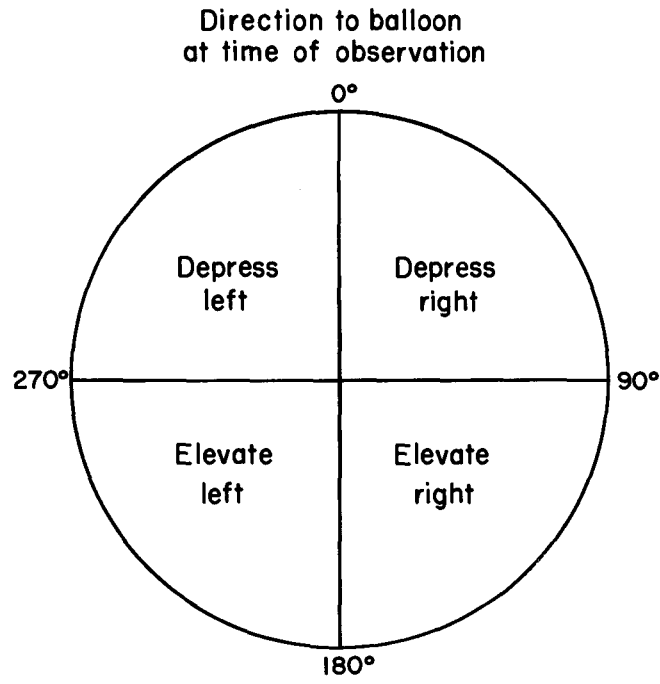

Figure 142. Wind compass for low-level winds.

CHAPTER 24

ARCTIC AND JUNGLE OPERATIONS

Section I. ARCTIC OPERATIONS

225. General

a. No specific instructions can be given which will cover all arctic operations. Conditions will vary greatly from season to season and from one area to another. The types of surfaces over which operations are conducted will vary as greatly as the weather. During warm summer months, the surface may be one of tundra or muskeg. In winter, the surface normally will be covered with ice and/or snow of varying depths. The instructions in this section pertain to operations under conditions of extremely low temperatures. Before a unit or an individual moves into an arctic region, a reference on climatology should be checked to ascertain the meteorological conditions that may be expected in that area.

b. The general area in which the met section operates will be determined by the area of operations of the unit to which it is assigned. The location of the met section will be limited further by the mobility of its vehicle; therefore, it usually will be near cleared roads or trails. The rules for selecting the sites for the individual items of meteorological equipment are the same as those given in preceding chapters. In addition, the equipment should be located so that personnel making an observation or performing maintenance will be exposed for a minimum amount of time. An arrangement of guide ropes should be provided to assist the observers in moving from one installation to another during periods of extremely limited visibility.

226. Operating Procedures and Maintenance

a. Test under conditions of extreme cold have proved that the mission of an artillery met section can be accomplished with the equipment currently authorized. With proper maintenance and winterization, the met equipment will generally function as well in arctic climates as in temperate climates. Hardships will be alleviated, to some extent, by the proper use of the clothing and equipment issued. The mobility of the section will

decrease, to the same degree as the mobility of all units equipped with wheeled vehicles decreases for operation in extreme cold.

b. The rules for operating procedures and use of the equipment are generally the same as those given in preceding chapters. Installation of equipment requires more time under conditions of extremely low temperatures than under conditions of moderate temperatures. Also, it will be extremely difficult to maintain the rigid schedule of flights which is expected in Temperate Zones. Numerous difficulties will develop; their corrections will depend on the training and experience of personnel and on the facilities and supplies available in the area.

c. Maintenance of equipment must be a continuous process. Vehicular equipment and the power unit must receive more attention in low temperatures than in the Temperate Zones.

d. For information relating to permanent or semipermanent operation in the Arctic, see FM 31-70.

e. Normal lubrication procedures for meteorological equipment are inadequate for operations in extremely low temperatures (below -35° C.) for the following reasons:

(1) Congealing of lubricants increases the torque required to operate some equipment, causing erroneous meter readings or recordings.

(2) Thickening of lubricants prevents capillary flow of oil through wicks and circulatory systems, thus preventing the oil from lubricating properly.

(3) Certain lubricants have been developed for use in low temperatures to help combat these conditions. For information regarding lubricants for met equipment in extremely low temperatures, refer to the appropriate technical manuals listed in appendix A.

f. When the temperature is -35° C. or lower, care must be exercised in using equipment outside. For example, theodolite material becomes extremely brittle and shatters easily in low temperatures. The instrument should be placed outside at least 1 hour prior to using, and care must

be taken by the operator not to exert any unnecessary pressure in adjusting the instrument. The focusing knob should be present before the instrument is taken outside to prevent possible breakage. Antifog compound should be used on lens.

g. Several other special precautions which must be observed when operating in cold weather are listed below:

(1) *Cables.* Extra care must be taken in handling electrical cables. Cold temperatures cause the insulation to become extremely hard and brittle; bending will cause breakage.

(2) *Safety precautions.* Personnel must ground themselves, as well as the equipment, when using hydrogen. Static electrical charges are severe, and extreme care must be taken in grounding procedures. Winter woolen clothing must be kept from rubbing against the hydrogen-filled balloons. When operating in the Arctic, every effort should be made to obtain helium for balloon inflation.

(3) *Inflation nozzles.* Extra nozzles should be requisitioned for inflating balloons, since the nozzles must be thawed between flights.

(4) *Personnel.* Metal should not be handled with the bare hands, since the flesh will freeze and stick to the metal.

(5) *Rawin set.* The rawin set must be warmed up at least one-half hour before any movement of the set for operation is attempted. The set should be moved by hand in elevation and azimuth before applying electrical power. Care

must be taken to insure that the equipment is leveled before each flight, since the thawing and freezing of the soil causes a constant movement of the equipment.

(6) *Psychrometers.* Since temperatures are almost always below 0° C., the rule is to allow ice to form on the wet bulb before use, since the heat of fusion released in the freezing of the water-saturated wick will cause erroneous readings. When temperatures are lower than -5° C., the wet-bulb reading is not necessary for ballistic or sound ranging computations. In this case, the arctic thermometer ML-352/UM should be used. The temperature scale on this thermometer is from 35° F. to -79° F.

(7) *Vehicles and generators.* The technical manuals and bulletins for vehicles and generators are listed in DA Pamphlet 310-4 and issued by the area command. Vehicles and the plotting area inside the van should have at least one window open for ventilation to prevent carbon monoxide poisoning.

(8) *Radiosondes.* Care should be taken not to spill any water on the plug that connects the baseline check set to the radiosonde, since the water may freeze. After the baseline check is completed the radiosonde should be allowed to weather outside, away from all buildings. A check should be made prior to release to insure that the correct surface temperature is being measured by the radiosonde.

Section II. JUNGLE OPERATIONS

227. General

a. When military operations are conducted in jungle regions, equipment and supplies are subjected to climatic conditions far different from those of temperate regions. The heavy rainfall and the continuously high relative humidity of most jungle areas introduce numerous problems in the performance and serviceability of equipment that are not encountered in temperate regions. In jungle warfare, all items of materiel must be adequately protected against the effects of prolonged exposure to the high temperature and humidity of the air and the ravages of insects and fungi.

b. Microscopic plant (fungi) forms and grows on materials that remain wet for long periods of time. Well-known forms of such growths are mold, mildew, and slime. These fungi secrete a corrosive fluid which is detrimental to wood, rub-

ber, wax, paper, fabrics, cork, leather, wool, and glass as well as to metals and insulation on electrical conductors.

c. A few general effects which result from inadequate protection against excessively high temperature, relative humidity, and/or fungi are listed below.

(1) Corrosion of many materials is greatly accelerated.

(2) Radio and electronic equipment become inoperable.

(3) Fabric materials become unserviceable.

(4) Etching of glass renders optical instruments unusable.

228. Treatment of Equipment

a. Equipment used in the jungles can be protected by various means. The equipment can be treated with a protective fungicidal, moisture-re-

sistant coating; the components can be redesigned; or materials can be substituted to reduce or eliminate the effect of moisture and fungi on the equipment. A moisture-resistant and fungi-resistant treatment which provides a reasonable degree of protection against fungus growth, insects, corrosion, salt spray, and moisture has been adopted for signal corps equipment. This fungi-resistant varnish or lacquer is applied with either a spray gun or a brush. This treatment is generally performed at the factory or by field maintenance personnel.

b. Thorough application of a fungicidal varnish or lacquer will protect the covered parts from the detrimental effects of both moisture and fungi for approximately 6 months. However, when the equipment is used under extreme weather conditions, it will probably be necessary to apply the treatment more often.

c. Dust also is a formidable enemy in the tropics. It sticks to any object with which it comes in contact, forming a hard crust over the surface. In addition to being harmful to electrical switches, relays, and capacitors, dust acts as an excellent medium for airborne fungus spores, which attach themselves to the equipment and instantly begin to grow. For these reasons, every

possible effort should be made to keep dust from settling on equipment.

229. Special Operating Procedures

a. Special precautions must be taken when operating met equipment in tropical climates. Great care must be taken to prevent the treated surfaces from becoming chipped, dented, scratched, or otherwise defaced; such conditions provide a vulnerable point for damage by moisture and/or fungi. The need for frequent and thorough inspection of all treated equipment is emphasized. Varnish that is cracking, peeling, or showing a whitish color, should be cleaned off, and a new coat should be applied. If any treated surface accidentally becomes marred, scratched, cut, dented, or otherwise defaced, the damaged portion should be repaired and covered immediately with the protective varnish.

b. If hydrogen is generated too rapidly, the chemical reaction of the calcium hydride charges may be controlled by the number of holes punched out in the top of each charge.

c. See appropriate technical manuals for special considerations in operation of specific pieces of equipment.

CHAPTER 25

DETERMINATION OF TEMPERATURE AND HUMIDITY INDEX

230. Purpose of a Temperature and Humidity Index

For some time, there has been a need for a method of measuring the amount of discomfort to which the human body is subjected during hot and humid days. Generally speaking, when the air temperature is extremely high and the relative humidity is also high, a person perspires more than usual, especially when performing heavy labor. The United States Weather Bureau has established a standard system to be used in their installations for determining a temperature and humidity index, sometimes called the discomfort index. This index was reported to the general public for the first time in 1959.

231. Computation of Temperature and Humidity Index

The temperature and humidity index (THI) is computed by applying a simple linear adjustment to the sum of the dry-bulb and wet-bulb readings obtained from the psychrometer. The formula is $THI = (t_d + t_w) 0.4 + 15$, where t_d is the dry-bulb temperature and t_w is the wet-bulb temperature, both in degrees Fahrenheit. The two temperatures are added, the sum multiplied by 0.4, and 15 added to the product. The figures 0.4 and 15 are arbitrary numerical constants determined by Weather Bureau mathematicians. The final result is the temperature and humidity index.

Example: Temperature and humidity index = $(t_d) 91.4^\circ \text{ F.} + (t_w) 85.6^\circ \text{ F.} = 177.0 \times 0.4 = 70.8$ or 71 (rounded off) + 15 = 86.

Note. Although every person has a different reaction to the heat and humidity, the Weather Bureau has calculated the discomfort index based on averages. The wind effect is not considered in this index. When the temperature and humidity index is 70, 10 percent of the people in the area are uncomfortable; when the index is 75, 50 percent of the people are uncomfortable; when the index is 80 or higher, everyone is uncomfortable. An index above 85 is considered the danger zone.

232. Wet-Bulb Globe Temperature Index

a. A wet-bulb globe temperature index

(WBGT), as specified by the American Society of Heating and Ventilating Engineers, has been used as a work discomfort index. This index is more realistic than the temperature and humidity index but is more difficult to compute. Generally, artillery met sections do not have a capability of measuring a WBGT index. Artillery met sections could be equipped to make the measurement at fixed installations.

b. The WBGT index is computed from reading of (1) a stationary wet-bulb thermometer exposed to the sun and to the prevailing wind, (2) a black globe thermometer similarly exposed, and (3) a dry-bulb thermometer shielded from the direct rays of the sun. All readings are taken at a location representative of the conditions to which men are exposed. The wet-bulb and black globe thermometers are suspended in the sun at a height of 4 feet above ground, as shown in figure 143. A period of 30 minutes should elapse before readings are taken.

c. The wet-bulb thermometer is a standard, laboratory, glass thermometer with its bulb covered with a wick (heavy white corset or shoe string). The wick extends into a flask of clean water, preferably distilled water. The mouth of the flask should be about three-fourths of an inch below the bulb of the thermometer. The water level in the flask should be high enough to insure wetting of the wick. The water should be changed daily after rinsing the flask and washing the wick with soap and water. To avoid erroneous readings, the water and wick must be free of salt and soap.

d. The globe thermometer consists of a 6-inch hollow copper sphere painted a dull black color on the outside and containing a thermometer with its bulb in the sphere. The thermometer stem protrudes to the outside through a rubber stopper. The stopper is tightly fitted into a brass tube soldered to the sphere (fig 143). The sphere has two small holes near the top used for suspending the sphere with piano wire. The globe must be kept dull black at all times and must be

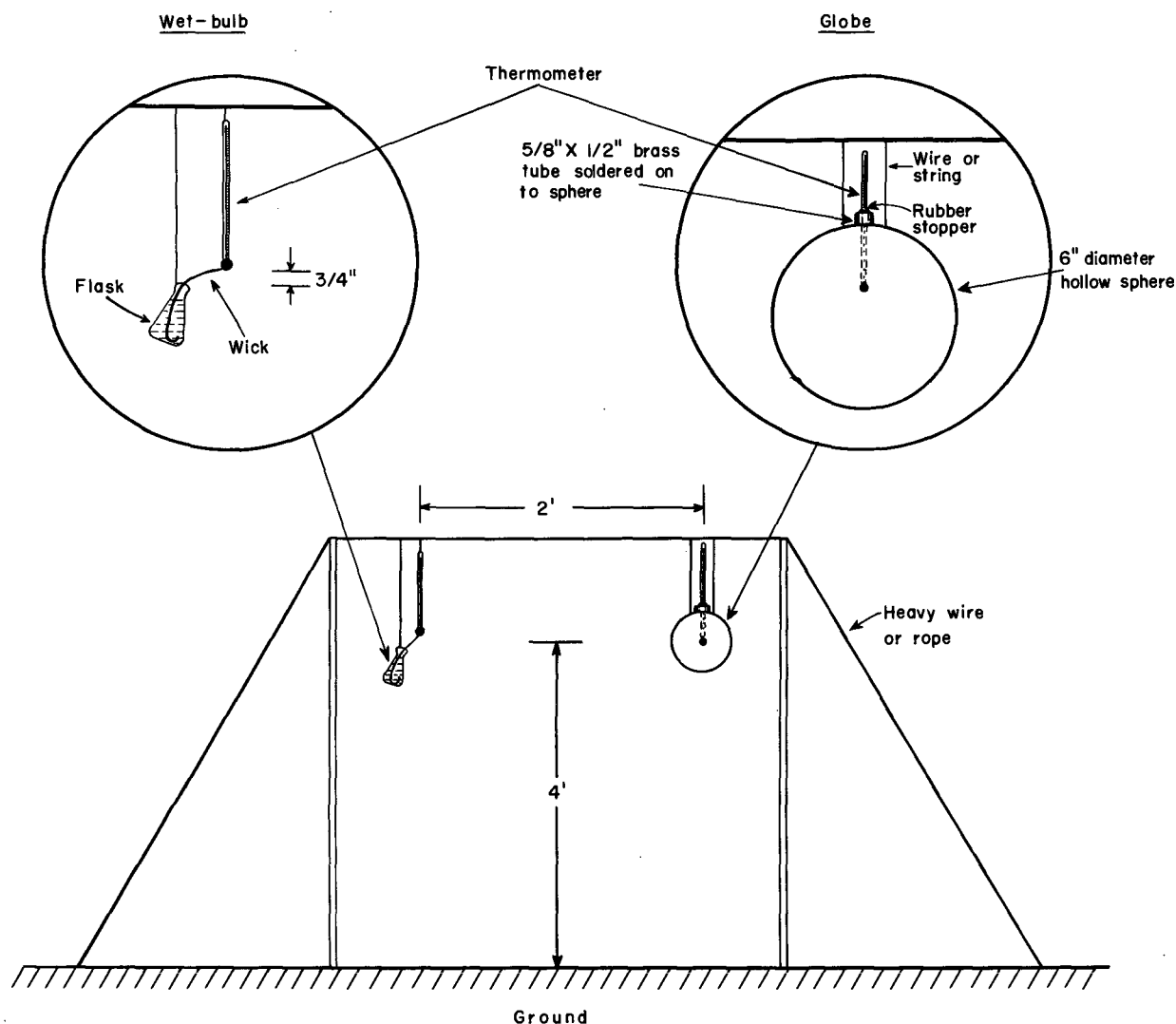

Figure 143. Equipment for measuring WBGT index.

kept free of dust or rain streaks by dusting, washing, or repainting if necessary.

e. The WBGT index is computed by using the formula $WBGT = [(WBT) \times 0.7] + [(BGT) \times 0.2] + (t_d \times 0.1)$, where WBT is the wet-bulb temperature, BGT is the black-globe temperature, and t_d is the dry-bulb temperature (shade).

Example:

WBT	$80^\circ \text{ F} \times 0.7 = 56^\circ$
BGT	$120^\circ \text{ F} \times 0.2 = 24^\circ$
t_d	$90^\circ \text{ F} \times 0.1 = 9^\circ$
WBGT	$= 89^\circ$

233. Use of the WBGT Index in the Control of Physical Activity

The proponents of the WBGT index have proposed the standards for application of the index. It should be emphasized that the temperatures

must be measured at a site which is the same or closely approximates the environment to which personnel are exposed.

a. When the WBGT index exceeds 80° , discretion should be used in planning heavy exercise for unseasoned personnel.

b. When the WBGT index reaches 85° , strenuous exercises, such as marching at standard cadence, should be suspended for unseasoned personnel during their first 2 weeks of training. At this temperature, training activities may be continued on a reduced scale after the second week of training.

c. Outdoor classes in the sun should be avoided when the WBGT index exceeds 85° .

d. All physical training should be suspended when the WBGT index reaches 88° . Hardened

personnel, after having been acclimated each season, can carry on limited activity at a WBGT index of 88° to 90° for periods not exceeding 6 hours a day (Technical Bulletin MED 175).

234. Wind Effect on Temperature

Air movement a great influence on the effect of temperature on personnel. A soldier working in a well-ventilated area can withstand a higher temperature than a soldier working in a confined

area. The temperature and humidity index or the WBGT index may be modified to some lower value when the air movement is known. At low temperatures, the effect of the wind is quite pronounced and is described in chapter 26 as wind chill. Wind effect temperature tables have not been computed for hot temperatures. An indication of effect of wind on hot temperatures can be seen by examining the top line of table VII, the wind chill table, in chapter 26.

CHAPTER 26

DETERMINATION OF WIND CHILL FACTOR

235. Purpose of a Wind Chill Factor

a. The human body is greatly affected by wind which sets in motion the process of convective cooling. This cooling alters the human body's metabolism and greatly increases the danger of freezing any exposed tissue. The wind removes the layer of radiated heat which normally surrounds the human body, unless this heat is trapped between layers of clothing with a wind-resistant outer garment.

b. In any future campaign where dispersion and isolation will be the rule rather than the exception, commanders may not be able to obtain immediate advice from a medical officer for the prevention of cold injuries to troops. Thus, a commander must be able to recognize environmental conditions which are likely to cause cold injuries and must consider appropriate precautions in preparing and planning operations. Planning should include the timely requisitioning of supplies and equipment, the training of personnel

to operate in the cold, and the provision for receipt, dissemination, and utilization of met data.

236. The Wind Chill Table

a. The wind chill table (table 8), using the arguments of temperature in degrees Fahrenheit versus wind velocity in miles per hour, has been constructed by the U.S. Army Medical Service research staff in order to establish a means of determining the effectiveness of military operations, primarily the troops involved, under extreme weather conditions. The wind chill table is used to determine the wind chill factor. Instructions for using this table are printed at the bottom of the table with an example problem illustrated.

b. There may be instances when wind velocity will be given in knots and temperature in degrees Celsius. The formulas for converting to miles per hour and degree Fahrenheit are shown as a footnote to table 8. See also conversion tables, table Ii and chart XI, FM 6-16.

Table 8. Equivalent Temperatures on Exposed Flesh at Varying Wind Velocity (Wind Chill)

Temperature (degrees Fahrenheit)	Wind velocity (miles per hour)										Factor
	45	35	25	20	15	10	5	3	2	1	
90	89.5	89	88.5	88	87.5	87	86	84.5	83		
82	81	80.5	80	79.5	78	74	72.5	70	60		
72	71	69.5	68	67	65	57	53.5	47.5	23		
63	61	59	57	55	52	39	34.5	20	-11		
51	49	47	45	42.5	38	18.5	11	0	-27		
41	39	36	34	30.5	25	0	-9	-23.5	-38		
30	28	25	23	18	11	-16.5	-40	Below -40	Below -40		
20	18	14	11	6	-2	Below -40	Below -40	do	do		
10	7.5	3	0	-6	-15	Below -40	Below -40	do	do		
0	-2.5	-8	-12	-18	-29	Below -40	Below -40	do	do		
-11	-14	-18	-23	-30	Below -40	do	do	do	do		
-21	-24	-30	-35	Below -40	do	do	do	do	do		
-32	-35	-40	-40	do	do	do	do	do	do		

(1) Obtain the temperature and wind velocity.
 (2) Locate the wind velocity column corresponding to the expected wind speed (or the wind speed closest to this).
 (3) Read down this column to the temperature corresponding to the expected temperature (or the temperature closest to this).
 (4) On the same line as the temperature, read the value in the column for 0 wind velocity. This value is the equivalent temperature.

Example: Weather information gives the expected temperature to be 35° F. and the expected wind velocity to be 20 miles per hour at midnight. Locate the 20 mph column and read down this column to the temperature nearest 35° F. The nearest temperature is 34° F. From 34° F. move all the way to the right on the same line and find the factor of -38° F. The factor -38° F. means that with a temperature of 35° F. and a wind speed of 20 mph, the rate of cooling of all exposed flesh is the same as -38° F. with no wind.

Conversion formulas:
 °F. = 9/5 (° C.) + 32
 MPH = Knots (0.868)
 °C. = 5/9 (° F. - 32)
 Knots = MPH (1.152)

CHAPTER 27

INSPECTIONS AND INSPECTION CHECKLISTS

Section I. GENERAL

237. General

Inspections are essential to insure that the mission is prepared to accomplish its assigned mission at all times. Systematic inspections provide the best insurance against unexpected breakdowns at a critical moment when maximum performance is essential. All inspections of equipment are conducted under command authority. They are the means by which commanders at all echelons ascertain the serviceability of equipment and the status of maintenance.

238. Command Maintenance Management Inspections

a. Command maintenance management inspections insure the proper utilization of equipment, supply economy, compliance with the maintenance principles set forth in Department of the Army publications, and evaluated operational readiness. Command maintenance management inspections are conducted as prescribed in AR 750-8. They are intended to make available to Commanding General, U.S. Continental Army Command; ZI Army Commanders; Commanding General, Military District of Washington, U.S. Army; overseas commanders; Commanding General, Air Defense Command; and heads of technical services a single inspection report on the following factors:

- (1) Serviceability, proper usage, and operational readiness of a unit's major items of equipment, together with their applicable on-vehicle and on-carriage materiel.
- (2) The adequacy and effectiveness of organizational and/or field maintenance operations.
- (3) The efficiency of repair parts supply procedures directly supporting maintenance operations.
- (4) The proficiency of unit maintenance personnel.
- (5) Future maintenance and exchange requirements derived from shortcomings disclosed during the inspection.

b. The checklist of Signal Corps equipment in appendix B will be used to inspect organizational maintenance and related supply facilities during command maintenance inspections. This checklist is normally used by major commanders and signal corps spot check inspection teams.

239. Spot Check Inspections

Spot check inspections are performed for the purpose of ascertaining the adequacy and effectiveness of organizational maintenance. Major commanders and the heads of Department of the Army agencies are responsible for insuring that spot check inspections are performed on equipment or organizations and activities under their command. Spot check inspections are described in chapter 8, DA Pam 700-2.

a. There are two types of spot check inspections—those ordered at division or higher level and conducted by technical service teams; those ordered below division level and conducted by organizational maintenance personnel. Both types have the same basic characteristics and purposes. They may be accomplished with or without prior warning to the unit to be inspected. The purposes of the spot check inspection are—

- (1) To detect incipient failures before equipment becomes unserviceable.
- (2) To insure the adequacy and effectiveness of organizational maintenance and supply procedures.
- (3) To ascertain the availability and use of technical manuals and lubrication orders.
- (4) To determine the accuracy of records.
- (5) To check authorized levels of equipment, repair parts, and supplies.
- (6) To check practice of supply economy and preservation and safekeeping of tools.
- (7) To check knowledge of proper procedures for requisitioning supplies and equipment.

b. The checklist in appendix B will be used to determine minor shortcomings in Signal Corps equipment inspected. This checklist will normally

be used by Signal Corps spot check inspection teams at division or higher level. Organizational maintenance personnel conducting spot check

inspections below division level may use the same checklist.

Section II. COMMAND INSPECTIONS

240. General

a. Command Responsibility. Commanders are required to insure that all equipment issued or assigned to their command is maintained in a serviceable condition and is properly used and that personnel under their command comply with technical instructions. The first requirement for attaining a high standard of maintenance is a program to keep the commander informed as to the state of maintenance within his command. This is best accomplished through maintenance inspections. The battalion is generally considered the largest unit in which a commander can be fully aware, by personal observation and inspection, of the condition of all types of weapons and equipment for which he is responsible.

b. Direct Responsibility. Direct responsibility is defined as responsibility of individuals for equipment entrusted to them for their individual use or use by subordinates.

241. Inspections

Strictly speaking, all inspections are a command function in that they are always conducted under command authority. However, the principal characteristic of the command inspection is that the commander personally participates. There are two types of command inspections, formal and informal.

a. Formal Command Inspections. The formal command inspection involves advance notice and a set procedure. It normally applies to all phases of unit activity, including personnel and all types of equipment. This thorough inspection of the unit requires considerable time and preparation. The advance notice should specify the units to be inspected and the manner in which the inspection will be conducted (including the specific way in which equipment is to be displayed).

(1) Although the commander personally participates, he employs inspecting parties to assist him with the inspection. These inspecting parties include various members of his staff and technical assistants. Specific composition of the parties depends on the level at which the inspection is being conducted.

(2) The formal command inspection is only one element in the overall inspection system, and it has certain specific purposes and advantages. It

gives the unit time to prepare and that is what is intended. Thus, subordinate unit commanders are given an opportunity and the incentive to evaluate their unit's preventive maintenance program and to correct shortcomings. However, it should be kept in mind that the ability of the unit to properly prepare to lay out its equipment in neat and orderly fashion and, in general, to be prepared to "meet the commander" is some indication of unit morale and efficiency.

b. Informal Command Inspections.

(1) The informal command inspection is also characterized by the commander's personal participation. However, unlike the formal command inspection, the informal command inspection can be made at any opportune time or place and is usually made without prior notice. The informal inspection differs from the formal inspection in another respect, it provides the commander with firsthand information on the actual day-to-day condition of his equipment and the maintenance proficiency of the personnel. Usually the informal inspection will involve no set procedure.

(2) The informal command inspection is the day-to-day life blood of the preventive maintenance program. It is a normal part of the commander's daily check of his units. Preventive maintenance is every soldier's job.

242. Inspection Procedure

This paragraph outlines a detailed inspection procedure and layout for each group of equipment in the met section and lists the essential items to be inspected. Introductory remarks concerning each group of equipment describe a suggested method of inspection to best determine both the operating efficiency of the equipment and, where applicable, the proficiency of the personnel operating the equipment. In addition to the checks listed, the inspector should insure that preventive maintenance, as outlined in chapter 6, is being performed by the operating personnel.

a. Checklist. The checklist in appendix B may be used by commanders as an overall checklist to determine minor discrepancies in met sections.

b. Layout of equipment. There are no regulations that state how the met equipment will be displayed. However, it should be displayed in a

neat, orderly, and military manner to facilitate the inspection procedure. Equipment should be displayed in such a manner that all nomenclatures or numbers can be seen. If the equipment has a carrying or packing case, it should also be displayed. When tool sets are displayed, the tools should be displayed in the sequence shown on the parts list. This will save time for the inspector as well as the section personnel. Every item should be displayed.

c. Surface Observation Equipment. For the best results, surface observation equipment is inspected during normal operation. While the equipment is being used, the commander has an opportunity to check on the proficiency of the personnel, as well as on the physical condition and operating efficiency of the equipment. The following checklist emphasizes the essential items to be inspected:

- (1) Are all components present and clean?
- (2) Are authorized spare parts on hand?
- (3) From a brief visual inspection, are there any broken or missing parts or any parts that require maintenance and repair?
- (4) Does the theodolite track properly with the tracking controls engaged?
- (5) Can the theodolite be properly leveled?
- (6) Do the night lights on the theodolite work (brightness control on the crosshairs and scale lights)?
- (7) Is the wick of the psychrometer clean?
- (8) Do the two thermometers of the psychrometer indicate identical temperatures when the psychrometer is whirled with the wick removed? If not, is an appropriate temperature correction recorded?
- (9) Does the barometer pointer move when the barometer face is lightly tapped?
- (10) Does the anemometer function properly and is the density correction chart available?

Note. If the surface observation equipment cannot be inspected during operation, figure 24 is a guide for the equipment layout for the inspection. For detailed information on equipment, see appropriate technical manuals.

d. Inflation Equipment. Inflation equipment should be inspected under the same conditions as the surface observation equipment, i.e., under normal operating conditions.

- (1) Are all components present and free from thick deposits of residue? (It is impossible to keep the inflation equipment, particularly the generator and 32-gallon water can, free from residue. However, vigorous cleaning of this equip-

ment immediately after use will keep it operational.)

- (2) From a brief visual inspection, are there any broken or missing parts or any parts that require maintenance and repair?

- (3) Are authorized spare parts on hand.

- (4) Are all hoses and internal passages of the generator and nozzles free from clogging deposits of residue?

- (5) Do the generators, hoses, or connections leak gas?

- (6) Are all metal surfaces of the inflation setup properly grounded? (See paragraph 57a for proper grounding procedure).

- (7) Is the inflation area free of debris (empty calcium hydride cans, packing cases, balloon cartons, etc) and is the water used in the inflation generator properly disposed of? (This white residue must be disposed of to maintain camouflage discipline.)

- (8) Is the inflation tent relatively draft proof and oriented with the rear of the tent facing into the direction of the prevailing wind?

- (9) Is the inflation area clearly marked as a "No Smoking" area?

- (10) Are pilot balloons weighed off for proper rate of rise?

- (11) Are provisions made for conditioning pilot and sounding balloons (TM 11-6660-222-12)?

Note. If the inflation equipment cannot be inspected during operation, figures 36 and 37 are guides for the equipment layout for the inspection. For detailed information on inflation equipment, see TM 11-6660-222-12 and TM 11-2413.

e. Plotting Equipment. All plotting equipment should be clean, with all lines, numbers, and writing thereon clearly legible. Plotting scales and rules should show no signs of warping or cracking. Plotting equipment should be cleaned with soap and water, never with cleaning solvents or oils. The slide rule is delicate and should show no signs of abusive use. It is important that all plotting equipment described in chapter 6, section IV is available to the met section and is in a usable condition, since all of this equipment is required for normal operation. If the plotting equipment is not being used at the time of the inspection, figure 22 is a guide for the equipment layout for the inspection. For further information on plotting equipment, see TM 11-6660-218-12, TM 11-6660-218-25P and TM 11-2442.

f. Communication Equipment. The communica-

tion equipment is observed most effectively while in operation. If all components are operating properly, a two-way conversation is possible. The communication wire should never be anchored to the theodolite tripod leg, as any sudden tension on the wire might result in upsetting and seriously damaging the theodolite. All splices in the wire should be securely covered with friction tape. Tools should be clean and in a usable condition. If the communication equipment cannot be inspected in the operating setup, figure 31 is a guide for the equipment layout for the inspection. For detailed information of equipment, see TM 11-5805-201-12 and -35.

g. Rawin Set AN/GMD-1(). An overall evaluation of the condition of the rawin set is made best from an observation of its operation during a radiosonde flight. Proper operation of the rawin set is indicated by the continuous reception of the met signal at the radiosonde recorder and the automatic printing of angular data at the control-recorder. Also, if the rawin set is operating properly, it will automatically track the balloon-borne radiosonde. A positive answer to each of the following questions indicates efficient operation and proper utilization of the rawin set by the operating personnel:

(1) Does the antenna follow the radiosonde smoothly?

(2) Does the AN/GMD-1() operate without harsh or clashing noises or excessive vibrations?

(3) Is the position of the radiosonde centered in the reticle of the telescope? (If not, is there a correction being applied to the angular data extracted from the control-recorder tape?)

(4) Are all cables connected securely?

(5) Is the main cable entrenched at all points where vehicles are likely to run over it? (Six inches or deeper if tracked vehicles are expected in the vicinity.)

(6) Is the main cable free of sharp bends and is there sufficient slack at each end to prevent damage to the cable or cable connectors?

(7) Is the orientation and leveling of the rawin set checked before each flight?

(8) Do the angles on the control-recorder-tape read the same as the angles on the AN/GMD-1()?

(9) Is the rawin set grounded?

(10) Is the angular data from the control-recorder tape legible?

(11) Are preventive maintenance forms used?

Note. For further information on this maintenance and inspection checklist, see appropriate technical manuals.

h. Radiosonde Recorder AN/TMQ-5(). An overall evaluation of the condition of the radiosonde recorder is made best from observation of its operation during a radiosonde flight. The operation of the radiosonde recorder depends on the proper reception of the met signal by the rawin set. After the inspector has checked the rawin set, he may apply the checks listed below to the radiosonde recorder. A positive answer to each question indicates efficient operation and proper utilization of the recorder by the operating personnel.

(1) Does the recorder pen respond smoothly and rapidly to changes in the met signal?

(2) Is the vent open at the top of the recorder and is the fan turned on?

(3) Does the pen print exactly at zero when the SIGNAL SELECTOR switch is in the SC position?

(4) Are the baseline check and release data entered on the recorder record?

(5) Has the response of the recorder been checked recently for linearity?

(6) If the response is not linear, has a correction chart been prepared?

(7) Are the cabinet and the accessories case free of rust, corrosion, and moisture?

(8) Are all controls free of binding, scraping, and excessive looseness? (Controls should not be checked while a flight is being recorded.)

(9) Are all external cables and shock mounts free of cuts, breaks, fraying, deterioration, kinks, and strains?

(10) Is the fan operating without overheating?

(11) Is the area behind the fan free of dust and dirt?

Note. The radiosonde recorder AN/TMQ-5 should be displayed as in figure 54, if it is not in operation. For detailed information on the radiosonde recorder AN/TMQ-5, see the appropriate technical manual.

i. Radiosonde Baseline Check Set AN/GMM-1(). The inspector can best inspect the operation of the baseline check set during the performance of a baseline check. Positive answers to the following questions indicate efficient performance of the baseline check and satisfactory condition of the baseline check set:

(1) Is the fan turned on while the check is being performed?

(2) Is the radiosonde positioned so that the

temperature element is on the right side of the baseline check set?

(3) Are the test leads from the radiosonde properly connected?

(4) Does the plastic cup contain sufficient water to wet the wick of the psychrometer inside the set?

(5) Is the water fresh?

(6) Is the chamber door fastened?

(7) Is the baseline check continued until successive traces of temperature, humidity, and reference that are printed on the radiosonde recorder record repeat one another in an identical pattern?

(8) Are the baseline check set data checked (verified) by reference to the humidity-temperature computer *before* the radiosonde is removed from the baseline check set?

(9) Is the radiosonde removed from the chamber, weathered, and released without undue delay?

Note. An actual physical inspection of the baseline check set is made when the equipment is not in use. If the inspection is attempted while making a baseline check, interference will result. There should be no movement of personnel around the baseline check set while the baseline check is in progress. The control unit may be on top of the set or it may be remotod as far away as 30 meters using the cable for remote control. Figure 56 shows the baseline check set AN/GMM-1 with door open and radiosonde properly installed. When the set is not in operation, the packing case, reel, and cable are also displayed. For detailed information on the baseline check set, see TM 11-6660-219-12.

j. Frequency Standard TS-65()/FMQ-1. The inspector should check to see that all components of the test set are present and that condition is serviceable. The frequency standard is inspected with best results when the equipment is being used. Figure 55 shows the equipment layout for inspection. Cable CX-2337/TMQ-5 should be displayed with the frequency standard. For detailed information on the equipment, see TM 11-6625-213-12.

k. Test Set TS-538/U. The inspector should insure that all components of the test set are present and are being properly used. Test set TS-538/U is inspected with best results when the set is being used. Figure 57 shows the layout for inspection. For detailed information on the test set, see TM 11-6625-213-12.

l. Power Units. A thorough operational check of the power units may be made by using DA Form 2404 (Equipment Inspection and Maintenance Worksheet). The inspector should insure that the personnel of the section are performing preventive maintenance on these power units and that DA Form 2404 is completed when applicable. DA Form 2404 may also be used for a command maintenance or a spot checklist for both Signal Corps and Engineer power units. For detailed information on the 10 kw power units, see TM 5-6115-232-10.

CHAPTER 28

DETERMINATION OF PRESSURE ALTITUDES

243. Pressure Altitude Requirements

Such devices as missile altimeters, drone altimeters, and barometric fuzes require presetting so that they function at a specified height above the surface. The specified height is measured by a pressure-sensitive element. Because pressures at specified altitudes change with time, altimeters and barometric fuzes must be set just prior to use. Pressures at specified altitudes can be measured by a radiosonde, predicted from surface observations, or forecast. Forecasts of pressure are provided by the Air Weather Service and may be obtained by request through the S2-G2 channels. Radiosonde measurements of the atmosphere are routinely made by artillery met sections. These sections accurately determine the pressure at specific altitudes by measuring heights along a virtual temperature sounding curve plotted on chart ML-574/UM. The procedure is described in paragraph 141. In this chapter, a simple method is described whereby pressure altitudes may be predicted from surface measurements.

244. Pressure Altitude Relations

Pressure difference between any two altitudes in the atmosphere is a function of the mean virtual temperature of the air between the two levels. The relationship is shown graphically in figure 144. This graph relates pressure, difference in altitude, and mean virtual temperature in accordance with the hydrostatic equation. The vertical lines are mean virtual temperature lines (isotherms); the horizontal lines represent height in 50-meter intervals up to 4,000 meters. The oblique lines are isobars (lines of constant pressure).

245. Prediction of Pressure Altitude From Surface Measurements

a. The accurate determination of a pressure altitude depends on an accurate measurement of the surface pressure and a good estimate of the

mean virtual temperature of the air between the surface and the altitude under consideration. The surface pressure is measured by barometer ML-102() or a similar instrument. The use and operation of barometer ML-102 () are described in paragraph 50.

b. The mean virtual temperature can be estimated when the surface virtual temperature and the difference between the surface and the pressure altitudes are known. It may be assumed that the virtual temperature will decrease with an increase in altitude at the standard lapse rate of 6.5° C. per 1,000 meters. Also, it may be assumed that the mean temperature will be the same as the predicted midpoint temperature. The predicted midpoint temperature is obtained by *subtracting* from the surface virtual temperature the product of 6.5° C. times half the altitude difference in kilometers.

Example:

Surface virtual temperature	= 17.8° C.
Pressure altitude	= 826 meters
Surface altitude	= 624 meters
Height difference	= 202 meters
	202 meters = 0.202 kilometers
6.5° C. × 1/2(0.202 km)	= - (0.7)
Mean virtual temperature	= 17.1° C.

The determination of surface virtual temperature is explained in paragraph 161b.

c. The pressure-Height Chart, Chart XIV in FM 6-16, is used to compute the pressure. A point is plotted on the chart at the intersection of the surface pressure isobar and the *mean* virtual temperature isotherm. From this point, the distance corresponding to the difference in height between the surface altitude and the pressure altitude is measured along the mean virtual temperature isotherm, and a second point is plotted. A dashed line is drawn between two points. The pressure established by the second plotted point is the predicted pressure. The determination of a

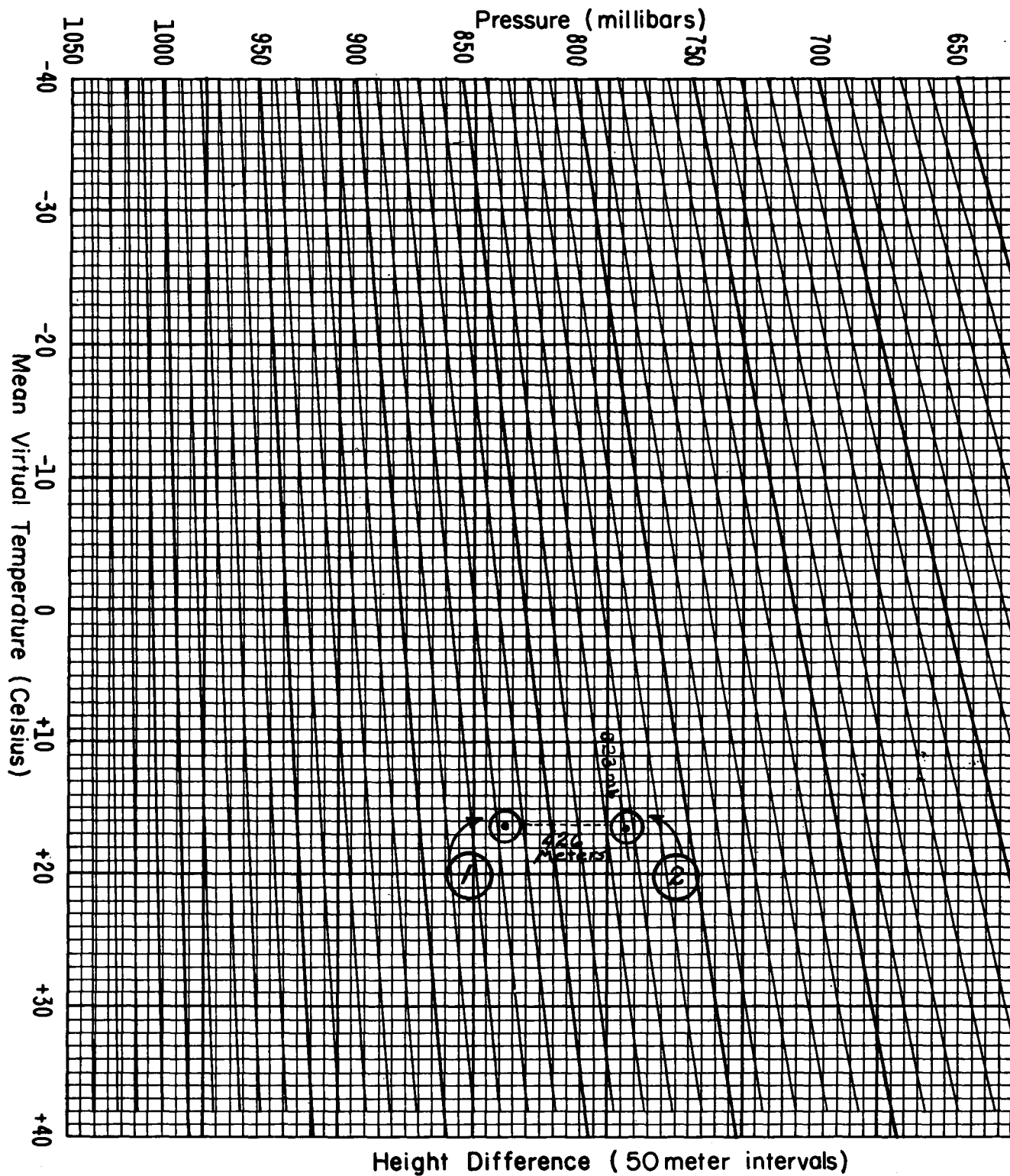

Figure 144. Pressure-height chart.

predicted pressure (fig 144) is illustrated below.

(1) *Measured surface data.*

- Surface pressure = 866 mb
(measured)
- Surface dry-bulb temperature = 16.4° C.
- Surface wet-bulb temperature = 13.3° C.
- wet-bulb depression = 3.1° C.
- Surface virtual temperature (table 1a, FM 6-16) = 17.8° C.

(2) *Computation of altitude difference.*

- Pressure altitude = 1,050 meters
- Surface altitude = 624 meters
- Altitude difference = 426 meters

(3) *Computation of mean virtual temperature.*

- 6.5° C. × 1/2(0.426 km) = 1.4° C.
- Surface virtual temperature = 17.8° C.
- Less altitude diff correction = 1.4
- Mean virtual temperature = 16.4° C.

(4) *Surface plot (1, fig 144).* A point is plotted on the pressure-height chart at a surface pressure of 866 mb and a mean virtual temperature of 16.4° C.

(5) *Pressure altitude plot (2, fig 144).* The distance corresponding to the difference in height

of 426 meters is plotted, and the pressure is read as 823 mb. Therefore, the pressure at an altitude of 1,050 meters is predicted as 823 millibars.

246. Validity of Predicted Pressure

Pressures predicted in the manner described in paragraph 245 are most valid at the time and place of the surface measurement. The smaller the height difference, the more valid the pressure determined. The same elements which invalidate a ballistic met message also invalidate a predicted pressure. Those elements are time, distance, terrain, and weather change. When an inversion (increase of temperature with height) exists between the surface and the pressure altitude under consideration, some error will be introduced in the computation of mean virtual temperature with the lapse rate of 6.5° C. per kilometer. A predicted pressure may be considered valid for a period of 2 hours and up to distances of 50 kilometers. When prominent terrain features, such as mountains or large lakes, intervene, the valid distance should be reduced. When rapid weather changes are occurring, both the valid time period and the valid distance should be reduced. Because of the infinite variety of weather patterns and terrain, no specific figures can be given as to how much to reduce the valid time and distance.

CHAPTER 29

DECONTAMINATION OF EQUIPMENT

247. General

a. Equipment which has been contaminated by a chemical, biological, or radiological agent constitutes a danger to personnel. Decontamination is the process of making any contaminated place or object safe for unprotected personnel. This can be done by covering, removing, destroying, or changing into harmless substances the contaminating agent(s). Generally decontamination is required only when a persistent agency has been used. A decision of a unit commander to carry out a decontamination operation will be based on the effect it will have on the unit mission. Extreme care must be exercised during decontamination. This care will include protection of personnel, moving of equipment before and/or after the application of neutralizing agents, or any combination thereof.

b. Although specific procedures are outlined below for the decontamination of exterior surfaces, the only known procedure for interiors and electronic components is that of aeration.

c. DS2 is effectively used in many cleaning procedures. See TM 3-220.

248. Decontamination of Chemical Agents

a. Rawin Set AN/GMD-1 (). When contamination is visible, apply a thin slurry (mixture of chlorinated lime and water) on exterior surfaces. Wash off the slurry with water, scrub with soap and water, and rinse thoroughly.

b. Control-Recorder. Decontaminate the exterior of the control-recorder in the same manner as the exterior of the rawin set. In addition, remove and discard the roll of paper tape.

c. Cables. Decontaminate the exposed parts of any cable by washing with soap and water only.

d. Theodolite. If the theodolite is exposed, clean as soon as possible with alcohol.

e. Baseline check Set, Radiosonde Recorder, and Like Equipment. The baseline check set, radiosonde recorder, and like equipment are decontaminated in the same manner as the rawin set and control-recorder. Discard the chart roll in the radiosonde recorder and replace it with a new chart roll.

f. Balloon Inflation Launching Device. Light contamination may be neutralized by aeration alone. For heavy contamination, apply slurry on surfaces which personnel are likely to touch and rinse thoroughly.

g. Weapons. Remove dirt, dust, grease, and oil; allow surfaces to air and then apply slurry. DS2 may be used on all metal surfaces except the bore. Hot water and cleaning solvent are also effective on metal surfaces and may be used in the bore. After decontamination, weapons should be dried and oiled.

h. Ammunition. Exposure to air and wind is the only practical method of decontaminating small-arms ammunition.

i. Automotive Equipment and Power Units. Light contamination may be neutralized by aeration. For heavy contamination, use slurry on surfaces which personnel are likely to touch. For remaining surfaces, wash vehicle or unit with water, scrub with soap and water and rinse thoroughly, or aerate.

249. Decontamination for Biological and Radiological Agents

After a biological or radiological attack the unit commander must, as with chemical contamination, make the decision as to whether or not to carry out decontamination. Biological and radiological decontamination is usually more difficult than chemical. Detailed methods to be followed are found in TM 3-220.

CHAPTER 30

DESTRUCTION OF EQUIPMENT

250. General

a. Tactical situations may arise in which it is necessary to abandon equipment in the combat zone. In such a situation, all abandoned equipment must be destroyed to prevent its use and compromise by the enemy.

b. The destruction of equipment subject to capture or abandonment in the combat zone will be undertaken only upon authority delegated by the division or a higher commander.

251. Principles

All met sections should prepare plans for destroying their equipment in order to reduce the time required, if destruction becomes necessary. The principles to apply are as follows:

a. Plans for destruction of equipment must be adequate, uniform, and easily carried out in the field.

b. Destruction must be as complete as the available time, means, and personnel will permit. Since complete destruction requires considerable time, priorities must be established so that the more essential parts are destroyed first.

c. The same essential parts must be destroyed on all like units to prevent the enemy from constructing a complete unit.

d. Spare parts and accessories must be given the same priorities as the parts installed on the equipment.

252. Methods

To destroy equipment adequately and uniformly, all personnel of the section must know the plan of destruction and priority of destruction.

a. *Smash.* Smash the controls, tubes, switches, loudspeakers, printing mechanisms, timers, clocks, all instruments on control panels, cylinder heads and blocks, carburetors, magnetos or distributors, storage batteries, fuel pumps, generators and starters, water pumps, telescopes, and testing equipment. Use sledges, axes, handaxes, pickaxes, hammers crowbars, or any heavy tool that will smash.

b. *Cut.* Cut the cords, wiring, cables, fuel and oil lines, generator windings, belts, ignition wires, radiators, tripods, and all remote cables, lines, and wires. Use axes, handaxes, machetes, or any other tool that will cut.

c. *Burn.* Burn the cords, wiring, manuals, cables fuel, oil, packing or carrying cases, tenting, wooden tripods, records, and instructions. Burn anything that will burn. Use gasoline, kerosene, oil, flame throwers, or incendiary grenades. When time is very limited, incendiary grenades are the most effective.

Warning. Gasoline vaporizes rapidly and may explode when ignited, causing injury or death to personnel nearby. When setting fire to gasoline-soaked material, stand away from the material and throw a lighted torch into it.

d. *Bend.* Bend the panels, cabinets, chassis, tools, housings, fuel tanks, skids, bases, and all other metal parts not otherwise destroyed.

e. *Explode.* To explode the equipment, use firearms, grenades, dynamite, or TNT.

f. *Dispose.* If time permits, dispose of the destroyed parts by burying them in slit trenches, fox holes, or other holes; by scattering them or by throwing them into streams or lakes.

CHAPTER 31

SAFETY PRECAUTIONS

253. General

In addition to the normal safety precautions to be observed in handling heavy equipment and practiced by the individual soldier, the meteorological personnel must be extremely cautious in handling the electrical equipment and hydrogen inflation equipment.

254. Hydrogen

Hydrogen gas is highly inflammable. Therefore, helium, an inert gas, should be used to inflate the balloons when possible. If bottled hydrogen or the hydrogen generator must be used, carefully observe the following safety precautions:

a. Display conspicuous warning signs where hydrogen is generated, used, or stored.

Example: DANGER—HYDROGEN—NO SMOKING WITHIN 15 METERS.

b. Never light a match, smoke, or cause a spark near a site where hydrogen is being generated or used. Remove all possible sources of flames and sparks.

c. If possible, wear rubber-soled shoes during the inflation.

(1) *Do not* wear shoes with exposed nails which might strike against metal, stones, or concrete floors and produce a spark.

(2) *Do not* drop or strike metal tools against anything that might cause a spark.

d. Remove all metallic objects, such as watches and eyeglasses, from personnel involved in the inflation of a balloon.

e. Never mix hydrogen with air. Expel all the air from the balloon before filling it with hydrogen.

f. *Do not* expose the hydrogen cylinder or generator to the sun. Always store hydrogen bottles and calcium hydride in the shade.

g. Static electricity is easily generated on days of low relative humidity. On such days, inflate the balloon slowly and lightly sprinkle the inflation area with water if the air temperature is above freezing.

h. Remove all constrictions from the balloon neck. Keep all hydrogen passages clear.

Caution: Unless all the talc is shaken out of

the balloon, talc may enter and clog the inflation nozzle.

i. When using bottled hydrogen gas, inflate the balloon slowly to avoid bursting or overinflation.

Warning: If the hissing sound of a gas leaking from the balloon is heard, close the cylinder valve immediately. Twist the neck of the balloon, remove it from the inflation launching device and release it.

j. Never deflate a hydrogen-filled balloon. Turn it loose.

k. When wearing heavy woolen or fur clothing in the immediate area in which inflation is in progress, wear a wrist band of metal connected to a flexible wire which is connected to a good ground. This will provide a path to ground for static electricity.

l. Ground the inflation equipment to provide a path to the ground for any static electricity generated in the equipment. Use wire to interconnect all metal parts of the inflation equipment (para 57).

m. Never remove the hydrogen generator from the water until the generation of hydrogen has stopped. Removing the generator from the water while hydrogen is being generated may cause an explosion. If the balloon is fully inflated before the calcium hydride charges are expended, dissipate the excess gas.

n. Pressure may exist within the calcium hydride charge; therefore, when punching the first knockout hole in the can, turn your face away to prevent possible injury.

o. For further information on hydrogen safety precautions see TM 11-6660-222-12 and TM 11-2413.

255. Electrical Equipment Safety Precautions

The first rule of safety is: *Be Careful:* Never touch a point in a circuit unless you know that it is not alive. The most dangerous circuits, high-voltage or low-voltage, are those which can deliver high currents. The danger is even greater when dampness is present or when the hands are perspiring.

a. Rawin Equipment. The following safety precautions must be observed when operating the rawin equipment.

(1) Do not make cable connections while power is being supplied to the system. Either open the main circuit breakers or turn *off* the power generator.

(2) While making electrical adjustments, keep one hand in your pocket so as not to touch "ground" during adjustment.

(3) Make certain that power is *off* before attempting to replace burned-out fuses.

(4) Make certain that the main assembly is adequately grounded at all times.

(5) Have the maintenance technician periodically check for shorts between the power line and equipment chassis.

(6) Make no adjustments on the main assembly during electrical storms.

(7) Assume that all electrical components possess lethal voltage until proven otherwise.

(8) *Do not* use steel wool to clean electrical

equipment or electrical equipment cabinets. Minute particles may enter the case and cause harmful internal shorting or grounding of circuits.

b. Power Generators. The following safety precautions must be observed when operating electrical power generators.

(1) Make sure the generator is properly grounded.

(2) Make sure the circuit breakers are in the OFF position before plugging in power cables.

(3) Do not attempt an adjustment or changes in wiring while the unit is in operation.

(4) Exercise extra precaution when the generator is being operated on wet or damp ground.

(5) Do not service the unit with gasoline while the unit is in operation.

(6) Since exhaust fumes are poisonous, provide adequate ventilation when power generators are being operated in confined spaces.

(7) The generator access panel should be closed while the power unit is in operation.

CHAPTER 32

QUALIFICATION TESTS FOR METEOROLOGICAL SPECIALISTS

256. Purpose

This chapter prescribes the tests to be given in the qualification of meteorological specialists. The tests are designed to measure the skill of the individual in artillery meteorology. School training or a technical background is not required prior to taking these tests. The tests are designed to determine the relative proficiency of the individual in the performance of duties as a member of a met section. The tests are not designed to determine the relative proficiency of the met section. The tests serve as an incentive for individuals in met sections to expand their knowledge to cover all duties in the section thereby increasing their value to the organization.

257. Preparation of Tests

a. The tests will be prepared under the direction of the battalion commander. The following considerations should guide their preparation.

b. The tests must be standardized so that the difference in test scores between any two individuals will be a valid measurement of differences in their skills.

c. Each individual in the section is a prospective candidate and the tests should be available upon his request.

258. Test Organization

The qualification tests are organized to allow the individual to take one test at a time if desired. A single test, when started, will be conducted from start to finish without interruptions.

259. Administration of Tests

a. The battery commander will be responsible for the testing of personnel within his battery. Generally, tests will be administered as follows:

(1) An officer, warrant officer, or enlisted man who is fully qualified and experienced in meteorology will be detailed as "examiner" to administer the tests.

(2) A complete, well-trained manning crew will be made available to operate the equipment, as needed, during the conduct of these tests. If a candidate fails any test because of the examiner or any assistant, the test will be disregarded and the candidate will be given another test of the same nature.

(3) The examiner will explain to the candidate the scope of the test and indicate the personnel who will act as his assistants. The examiner will critique the candidate's performance at the completion of the test and turn in the tentative score to the battery commander. The battery commander will finalize the score and forward the test score to the battalion.

b. In order to conserve expensive radiosonde equipment, the following coordinating instruction will be followed in administering the tests outlined in paragraphs 273 through 280.

(1) The tests outlined above will be conducted immediately before, during, and immediately after one radiosonde ascent. The test will be based on data collected and recorded during this ascent.

(2) All equipment required to produce a meteorological message by the radiosonde method will be made available for these tests.

(3) The tests will be conducted in the sequence in which they are presented in the test.

(4) Care will be taken to insure that the candidate and the assisting crew are familiar with the sequence and requirements of the tests.

260. Qualification

Minimum percentage scores required for qualification in the tests are as follows:

<i>Individual Classification</i>	<i>Percentage score</i>
Expert	90 percent
First-class specialist	80 percent
Second-class specialist	70 percent

261. Outline of Tests

Para No.	Subject	Number of tests	Points each	Maximum credit
262.	Theodolite ML-474/GM	3	1	3
263.	Hydrogen generator ML-303/TM and 30-gram pilot balloon	1	2	2
264.	Tracking pilot balloon	1	4	4
265.	Communication equipment	2	1.5	3
266.	Psychrometer ML-224	2	1.5	3
267.	Barometer ML-102	3	0.5	1.5
268.	Power unit 10Kw	3	1	3
269.	Plotting ballistic wind data from pibal observation	1	7	7
270.	Plotting and computing weather data for sound ranging	3		5
	Test 1 and 3	(2)	(1)	(2)
	Test 2	(1)	(3)	(3)
271.	Assembly, orientation, nomenclature, and maintenance of the rawin set AN/GMD-1()	4	1	4
272.	Nomenclature and presetting procedures for radiosonde recorder AN/TMQ-5()	2	2	4
273.	Preparation of the radiosonde AN/AMT-4() for flight	3		3.5
	Tests 1 and 2	(2)	1	(2)
	Test 3	(1)	1.5	(1.5)
274.	Preparation of train	1	1	1
275.	Hydrogen generator set AN/TMQ-3 and sounding balloon	1	4	4
276.	Baseline check	3		4
	Tests 1 and 2	(2)	1	(2)
	Test 3	(1)	2	(2)
277.	Operation of rawin set AN/GMD-1()	1	4	4
278.	Obtaining and evaluating the radiosonde record	1	9	9
279.	Determining ballistic densities and temperatures from radiosonde data	3		7
	Test 1	(1)	3	(3)
	Tests 2 and 3	(2)	2	(4)
280.	Determining zone winds from radiosonde data	3		10
	Test 1 and 2	(2)	1	(2)
	Test 3	(1)	8	(8)
281.	General and artillery meteorology	1	18	18
	Total	42		100

262. Theodolite ML-474/GM

a. Scope of Tests. Three tests will be conducted in which the candidate will be required to assemble, level, orient, check adjustment, and give the nomenclature of the theodolite ML-474/GM.

b. Special Instructions.

(1) The following equipment will be made available to the candidate.

(a) One theodolite ML-474/GM in carrying case.

(b) One tripod ML-78.

(2) One assistant will be furnished to help the candidate in checking the adjustment of the theodolite.

(3) The examiner will furnish the candidate the local magnetic declination and the location and angle of an established datum line.

c. Outline of Tests.

Test No.	Examiner commands—	Action of candidate
1	ASSEMBLE AND LEVEL THE THEODOLITE.	Removes the theodolite from the carrying case and assembles it on the tripod. Levels the instrument as prescribed in TM 11-6675-200-10.
2	ORIENT THE THEODOLITE BY THE MAGNETIC COMPASS AND ESTABLISHED DATUM LINE.	Orients the theodolite by the magnetic compass and by an established datum line as prescribed in TM 11-6675-200-10.
3	NAME PARTS DESIGNATED. (Examiner points to the following parts: compass, azimuth calibration adjustment, leveling screws, azimuth scale, elevation scale, brightness control, bubble levels, azimuth tracking control, elevation tracking control.)	Names the designated parts, using the nomenclature specified in TM 11-6675-200-10.

d. Penalties.

(1) *Test 1.* A penalty of 0.5 point will be assessed for each of the following errors:

(a) Any error in assembling the instrument to the tripod.

(b) Inability to level the instrument.

(2) *Test 2.* A penalty of 0.5 point will be assessed for an error of more than 0.5° in orienting the theodolite by the magnetic compass or by an established datum line.

(3) *Test 3.* A penalty of 0.1 point will be assessed for each error in nomenclature.

e. Credit. If each test is performed correctly, a maximum credit of 1 point will be awarded for each of the three tests.

263. Hydrogen Generator ML-303/TM and 30-Gram Pilot Balloon

a. Scope of Test. One test will be conducted in which the candidate will be required to generate the necessary hydrogen gas and inflate and shelter a 30-gram balloon.

b. Special Instructions.

(1) The following equipment will be furnished the candidate:

(a) One hydrogen generator ML-303/TM.

(b) Six balloons, 30-gram (two of each of the following colors: black, white, and red).

(c) One balloon nozzle ML-373/GM.

(d) The calcium hydride charges ML-304A/TM.

(e) One ball of twine RP-15.

(f) One pocket knife.

(g) One can, corrugated, nesting, 24-gallon.

(h) Twenty gallons of water.

(i) Three calcium hydride charges ML-305A/TM.

(j) Grounding equipment.

(2) The candidate will be required to assemble the hydrogen generator as part of the test.

(3) The balloons will be conditioned prior to the test, if required.

(4) The inflated balloon will be tied down in a sheltered place for use in a subsequent test.

(5) No penalty will be assessed for balloon breakage unless breakage is caused by carelessness on the part of the candidate.

(6) Candidate will select and prepare the balloon for inflation before generating the hydrogen.

c. Outline of Test.

Examiner commands—	Action of candidate
GENERATE HYDROGEN AND INFLATE A 30-GRAM BALLOON.	Generates hydrogen. Chooses a balloon of the proper color and inflates and ties it down.

d. Penalties.

(1) A penalty of 0.35 point will be assessed for each of the following errors:

(a) Use of an incorrect calcium charge.

(b) Failure to clean the generator properly after inflating the balloon.

(c) Failure to immerse the generator properly while generating the hydrogen.

(d) Use of a balloon of the wrong color for current weather conditions.

(e) Failure to weigh off the balloon correctly.

(f) Failure to inspect the inflated balloon for defects.

(g) Failure to properly ground all inflation equipment.

(2) Time penalties will be assessed as follows:

Time in minutes, exactly or			
less than	15	20	25
Penalties	0	0.5	1.0

e. Credit. If the test is performed correctly within the minimum time limits, a maximum credit of 2 points will be awarded.

264. Tracking Pilot Balloon

a. Scope of Test. One test will be conducted in which the candidate will be required to track a pilot balloon and read the scales of the theodolite.

b. Special Instructions.

(1) The following equipment will be furnished the candidate:

(a) One theodolite ML-474/GM.

(b) One tripod ML-78.

(2) One assistant examiner, preferably a trained weather observer, will be made available to release the balloon and act as timer-recorder.

(3) The following equipment will be furnished the assistant examiner:

(a) Two copies of DA Form 6-42 (Ballistic Winds From Observations of 30- or 100-Gram Balloons).

(b) One clip board.

(c) One timer PH-29 or FM-19.

(d) One pencil, 3H.

(e) One 30-gram or 100-gram balloon, properly inflated, and of the proper color.

(4) The balloon should be tracked for at least 10 minutes and 24 seconds.

(5) The examiner will check the tracking by observing the balloon through the open sight of the theodolite.

c. Outline of Test.

Examiner commands--	Action of candidate
TRACK PILOT BALLOON.	Tracks the balloon and reads the scales of the theodolite at the command READ, as prescribed in para 166, until directed to cease tracking.

d. Penalties. A penalty of 1 point will be assessed for each of the following errors:

(1) Any appreciable inaccuracy in tracking.

(2) Inability to operate the theodolite properly and without clumsiness.

(3) Failure to announce the elevation and azimuth readings promptly, accurately, and in the prescribed sequence at the command READ.

(4) Failure to stop tracking immediately at the command READ.

e. Credit. If the test is performed correctly, a maximum credit of 4 points will be awarded.

265. Communications Equipment

a. Scope of Tests. Two tests will be conducted in which the candidate will be required to estab-

lish communication between a plotting central and the theodolite, test the operation of the sound-powered telephones, and give the nomenclature of the communication equipment.

b. Special Instructions.

(1) The following equipment will be furnished the candidate:

(a) Two head and chest sets HS-25.

(b) One spool DR-8 with 1/4 mile of wire WD-1/TT.

(c) One tool equipment TE-33.

(d) Two jacks, JK-54.

(e) Sandpaper.

(f) One bristle brush, soft.

(2) The examiner will designate the location of the plotting central and the observation point to the candidate.

(3) One assistant examiner will be made available to assist the candidate in circuit checking.

c. Outline of Tests.

Test No.	Examiner commands--	Action of candidate
1	ESTABLISH COMMUNICATION AND TEST OPERATION.	Installs and assembles sound powered telephones. Checks for good connections.
2	NAME PARTS DESIGNATED. (Examiner points to five of the following parts: Jack, plug, transmitter, receiver, spool DR-8, tool equipment TE-33.)	Names each designated part as using the nomenclature specified in para 69.

d. Penalties.

(1) *Test 1.* A penalty of 0.5 point will be assessed for each error in installing and assembling communications equipment.

(2) *Test 2.* A penalty of 0.2 point will be assessed for each error in nomenclature.

(3) *Time penalties.* Time penalties are assessed as follows:

(a) *Test 1.*

Time in minutes, exactly or				
less than	8	10	12	14
Penalties	0	0.5	1.0	1.5

(b) *Test 2.* No time penalties are prescribed for test 2.

e. Credit. A maximum credit of 1.5 points will be awarded for each test performed correctly.

266. Psychrometer ML-224

a. Scope of Tests. Two tests will be conducted in which the candidate will be required to obtain a set of psychrometer readings and compute the relative humidity.

b. Special Instructions.

(1) The following equipment will be furnished the candidate:

- (a) One psychrometer ML-224.
- (b) One wick (new) with sizing removed, and thread for wick.
- (c) One pocket knife.
- (d) One bottle of clean, pure water at ambient air temperature.

(e) One copy FM 6-16.

(2) One trained assistant examiner will be made available to take psychrometer reading simultaneously with the candidate.

(3) One psychrometer ML-224 will be furnished the assistant examiner.

(4) The examiner will insure that both psychrometers read within the required tolerances before the test.

(5) Test 1 will be performed outdoors.

(6) The examiner will compare the readings and computed relative humidity obtained by the assistant examiner in grading.

c. Outline of Tests.

Test No.	Examiner commands—	Action of candidate
1	OPERATE PSYCHROMETER.	Installs the new wick. Operates and reads the psychrometer as prescribed in TM 11-6660-222-12.
2	COMPUTE RELATIVE HUMIDITY.	Computes the relative humidity as prescribed in para 52.

d. Penalties.

(1) *Test 1.* A penalty of 0.5 point will be assessed for each of the following errors:

(a) Failure to install and wet the wick correctly.

(b) Failure to operate the psychrometer properly on the sling and handle.

(c) Failure to obtain psychrometer readings that agree within 0.5° C with those obtained by the assistant examiner.

(2) *Test 2.* Penalties will be assessed on inaccuracy as follows.

Variance in percent	±4	±5
Penalties	0	1.5

e. Credit. If the tests are performed correctly, a maximum credit of 1.5 points will be awarded for each test.

267. Barometer ML-102

a. Scope of Tests. Three tests will be conducted in which the candidate will be required to read the barometer, convert units of pressure, apply corrections, and demonstrate maintenance.

b. Special Instructions.

(1) The following equipment will be furnished the candidate:

- (a) One barometer ML-102.
- (b) One copy FM 6-16.

(2) The barometric pressure in inches of mercury will be furnished the candidate.

c. Outline of Tests.

Test No.	Examiner commands—	Action of candidate
1	READ THE BAROMETER.	Reads the barometer as prescribed in TM 11-427.
2	CONVERT INCHES OF MERCURY TO MILLIBARS.	Converts the pressure in inches furnished him, using the conversion chart in FM 6-16.
3	DEMONSTRATE OR DESCRIBE MAINTENANCE OF BAROMETER.	Demonstrates or describes handling, accuracy, tolerances, maintenance, and method of calibration of the barometer as prescribed in TM 11-427.

d. Penalties.

(1) *Test 1.* A penalty of 0.3 point will be assessed for an error of more than ± 0.1 millibar in reading the barometer.

(2) *Test 2.* A penalty of 0.5 point will be assessed for an error in converting inches of mercury to millibars.

(3) *Test 3.* A penalty of 0.2 point will be assessed for each error made in demonstrating or describing the maintenance required.

e. Credit. A maximum credit of 0.5 will be awarded for each test performed correctly.

268. Power Unit 10Kw

a. Scope of Tests. Three tests will be conducted in which the candidate will be required to operate, adjust frequency, and demonstrate maintenance of the power unit, 10Kw.

b. Special Instructions. The following equipment will be furnished the candidate:

- (1) One power unit, 10Kw.
- (2) Issued tools for power unit.

c. Outline of Tests.

Test No.	Examiner commands—	Action of candidate
1	DEMONSTRATE MAINTENANCE.	Demonstrates items 1 through 10 (as appropriate to model) of before-operation service.
2	START THE POWER UNIT.	Starts the power unit.
3	ADJUST AND CHECK THE POWER UNIT.	Performs adjustment.

d. Penalties.

(1) *Test 1.* A penalty of 0.16 point will be assessed for each error in demonstrating the items of before-operation service.

(2) *Test 2.* A penalty of 0.5 point will be assessed for each of the following errors:

(a) Inability to start the power unit.

(b) Incorrect procedure in starting the power unit.

(3) *Test 3.* A penalty of 1 point will be assessed for inability to adjust the power unit.

e. Credit. If the tests are performed correctly, a maximum credit of 1 point will be awarded for each test.

269. Plotting Ballistic Wind Data From Pibal Observations

a. Scope of Test. One test will be conducted in which the candidate will be required to weight and plot the weighted zone winds and determine the ballistic winds.

b. Special Instructions.

(1) The following equipment will be furnished the candidate:

(a) One plotting board ML-122.

(b) One scale ML-577/UM.

(c) One copy of DA Form 6-57 (NATO Metro Message).

(d) One copy of FM 6-16.

(e) Two pencils, 3H; art gum; sandboard.

(2) A set of data for zone winds, including zone number, wind direction, and wind speed for 10 zones, will be furnished the candidate.

c. Outline of Test.

Examiner commands—	Action of candidate
DETERMINE THE BALLISTIC WINDS	Weights and plots the zone winds. Determines the ballistic winds as prescribed in para 169 for eight lines of type-2 or type-3 messages.

d. Penalties.

(1) A penalty of 0.5 point will be assessed for exceeding the following tolerances of accuracy:

(a) No tolerance allowed for surface and the first zone.

(b) For the second, third, fourth, and fifth zones, ± 100 mils in wind direction and ± 1 knot in wind speed.

(c) For the sixth, seventh, and eighth zones, ± 100 mils in wind direction and ± 2 knots in wind speed.

(2) Time penalties will be assessed as follows:

Time in minutes, exactly or									
less than	25	27	28	29	30	31	32	33	
Penalties	0	1	2	3	4	5	6	7	

e. Credit.

(1) If the test is performed correctly within the minimum time limit, a maximum credit of 7 points will be awarded.

(2) If the total penalties exceed 4 points, no credit will be awarded.

270. Plotting and Computing Weather Data for Sound Ranging

a. Scope of Tests. Three tests will be conducted in which the candidate will be required to plot the readings on a 30-gram balloon, determine the effective wind, and determine the effective temperature.

b. Special Instructions.

(1) The following equipment will be furnished the candidate:

(a) One plotting board ML-122.

(b) One rule ML-126A.

(c) One scale ML-577/UM.

(d) One copy of DA Form 6-48 (Weather Data for Sound Ranging).

(e) Two pencils, 3H; art gum; and sandboard.

(f) One copy FM 6-16.

(2) The following data will be furnished the candidate:

(a) Times of sunrise and sunset, time of release, sky condition, dry-bulb temperature, and wet-bulb temperature.

(b) A set of readings on a 30-gram balloon through 3 minutes 54 seconds of ascent to include time, elevation angle, and azimuth angle.

c. Outline of Tests.

Test No.	Examiner commands—	Action of candidate
1	PLOT READINGS	Plots the readings as prescribed in para 68.
2	DETERMINE THE EFFECTIVE WIND.	Scales and weights the winds. Determines the effective wind as prescribed in para 185.
3	DETERMINE THE EFFECTIVE TEMPERATURE.	Determines the effective temperature as prescribed in para 184.

d. Penalties.

(1) *Test 1.* A penalty of 0.5 point will be assessed for each error in plotting.

(2) *Test 2.* A penalty of 1.5 points will be assessed for the following errors:

(a) Wind direction in error by more than ± 20 mils.

(b) Wind speed in error by more than ± 1 knot.

(3) *Test 3.* A penalty of 1 point will be assessed if the effective temperature is in error by more than $\pm 0.2^\circ$ C.

(4) *Time penalties.* Time penalties will be assessed as follows:

(a) <i>Test 1.</i>					
Time in minutes, exactly or					
	less than	5	6	7	
	Penalties	0	0.5	1.0	
(b) <i>Test 2.</i>					
Time in minutes, exactly or					
	less than	7	9	11	13
	Penalties	0	1	2	3
(c) <i>Test 3.</i>					
Time in minutes, exactly or					
	less than	3	4	5	
	Penalties	0	0.5	1.0	

e. Credit. A maximum credit of one point for tests 1 and 3; and three points for test 2 will be awarded if the tests are performed correctly within minimum time limits.

271. Assembly, Orientation, Nomenclature, and Maintenance of the Rawin Set AN/GMD-1()

a. Scope of Tests. Four tests will be conducted in which the candidate will be required to assemble, orient, give the nomenclature, and demonstrate the preventive maintenance of the Rawin Set AN/GMD-1().

c. Outline of Tests.

Test No.	Examiner commands—	Action of candidate
1	COMPLETE ASSEMBLY OF THE GMD	Completes the assembly of the GMD so that it is prepared for operation as prescribed in TM 11-6660-206-10.
2	ORIENT THE GMD	Orients the GMD as prescribed in TM 11-6660-206-10.
3	NAME THE PARTS DESIGNATED.	Names the designated parts using the nomenclature specified in TM 11-6660-206-10.
	(Examiner points to 10 of the following parts: elevation unit assembly, rawin receiver, antenna control, jack screws, azimuth unit, compression bars, jack plates, reflector, antenna scanner assembly, telescope assembly, elevation stow lock, azimuth stow lock, azimuth angle indicator, frequency tuning switch, spirit levels.)	
4	PERFORM THE DAILY PREVENTIVE MAINTENANCE.	Performs the daily preventive maintenance as prescribed in TM 11-6660-206-10.

b. Special Instructions.

(1) The following equipment will be furnished the candidate:

- (a) One Rawin Set AN/GMD-1(), complete.
- (b) One power unit, 10Kw; or commercial power supply.
- (c) One radiosonde recorder AN/TMQ-5().

(d) One copy DA Form 2404 (Equipment Inspection and Maintenance Worksheet).

(2) The GMD will be emplaced in a good position for tracking, and the heavy components of the set will be assembled and leveled prior to starting the tests.

(3) All members of the meteorological section will be made available to assist during the test.

(4) The parts listed below will be laid near the set so that the candidate can complete the assembly without lose of time.

- (a) Telescope.
- (b) I-F and oscillator cables.
- (c) Mixer assembly.
- (d) Antenna scanner assembly.

(5) The examiner will furnish the candidate the azimuth and elevation angles to the orienting point.

(6) During test 4, the candidate will be allowed to refer to the equipment log book and maintenance forms.

(7) When test 4 is completed, the GMD will remain emplaced and untouched until the candidate is ready to tune it during the ground check.

d. Penalties.

(1) *Test 1.* A penalty of 0.25 point will be

assessed for each error in completing the assembly of the GMD.

(2) *Test 2.* A penalty of 1 point will be assessed for an error of more than 0.5° in orienting the GMD in azimuth or elevation.

(3) *Test 3.* A penalty of 0.1 point will be assessed for each error in nomenclature.

(4) *Test 4.* A penalty of 0.25 point will be assessed if any item of preventive maintenance is not performed correctly.

(5) *Time penalties.* Time penalties will be assessed as follows:

(a) *Test 1.*

Time in minutes, exactly or				
less than	-----	15	17	20
Penalties	-----	0	0.5	1.0

(b) *Test 2.*

Time in minutes, exactly or				
less than	----	10	12	14
Penalties	-----	0	0.5	1.0

(c) *Tests 3 and 4.* No time limits are set for tests 3 and 4.

c. Outline of Tests.

Test No.	Examiner commands—	Action of candidate
1	NAME PARTS DESIGNATED. (Examiner points to five of the following parts: SIGNAL SELECTOR switch, reference adjust, control panel, frequency-time recorder, signal data converter, pen carriage, manual chart advance knob, pen heater, rawin time print switch.)	Names each part designated using nomenclature as specified in TM 11-2436.
2	PERFORM PRESETTING PROCEDURES (10 operations).	Perform presetting procedures prescribed in TM 11-2436.

d. Penalties.

(1) *Test 1.* A penalty of 0.4 point will be assessed for each error in nomenclature.

(2) *Test 2.* A penalty of 0.2 point will be assessed for each error in performing the presetting procedures on the AN/TMQ-5().

e. Credit. A maximum credit of 2 points will be awarded for each test.

e. Credit. If the tests are performed correctly within the minimum time limits, a maximum credit of 1 point will be awarded for each test.

272. Nomenclature and Presetting Procedures of Radiosonde Recorder AN/TMQ-5()

a. Scope of Tests. Two tests will be conducted in which the candidate will be required to give the nomenclature of the AN/TMQ-5 and performs presetting procedures.

b. Special Instructions.

(1) The equipment used in paragraph 273 will be furnished the candidate.

(2) The AN/TMQ-5 will be alined and in good operating condition prior to the start of the test.

(3) When test 2 is completed, the AN/TMQ-5 will not be touched until the candidate is ready to use it during the ground check.

(c) One screwdriver, small.

(d) Test set TS-538/U.

(2) When test 3 is complete, the radiosonde will remain untouched until the candidate is ready to continue work on it during the ground check.

(3) Additional radiosondes will be made available to the candidate in event the first one is defective.

c. Outline of Tests.

273. Preparation of the Radiosonde AN/AMT-4() for Flight

a. Scope of Tests. Three tests will be conducted in which the candidate will be required to prepare the battery, assemble the radiosonde, perform the power check, and set the radiosonde frequency on the radiosonde transmitter.

b. Special Instructions.

(1) The following equipment will be furnished the candidate:

(a) One radiosonde AN/AMT-4() (disassembled).

(b) One battery pack BA-259/AM.

Test No.	Examiner commands—	Action of candidate
1	PREPARE BATTERY..	Prepares the battery for the flight as described on the battery cover.
2	ASSEMBLE THE RADIOSONDE.	Assembles the radiosonde as prescribed in para 108.
3	PERFORM POWER CHECK AND SET FREQUENCY.	Performs the power check and sets radiosonde frequency on radiosonde transmitter.

d. Penalties.

(1) *Test 1.* A penalty of 1 point will be assessed for failure to activate the battery properly.

(2) *Test 2.* A penalty of 0.5 point will be assessed for failure to insert the battery with the lid toward the top of the modulator.

(3) *Test 3.* A penalty of 1 point will be assessed for each of the following errors:

(a) Failure to check the battery power properly.

(b) Failure to set the radiosonde frequency on the transmitter properly.

e. Credit. Maximum credit of one point each for tests 1 and 2; and 1.5 points for test 3 will be awarded if the tests are performed correctly.

274. Preparation of Train

a. Scope of Test. One test will be conducted in which the candidate will be required to prepare the train for a radiosonde ascent.

b. Special Instructions.

(1) The following equipment will be furnished the candidates:

(a) One ball twine RP-15.

(b) One parachute ML-132.

(c) One pocket knife.

(2) The balloon train will be prepared and laid out in preparation for the ascent which will be made as soon as the sounding balloon is inflated and the ground check is completed.

c. Outline of Test.

Examiner commands—	Action of candidate
PREPARE TRAIN	Prepares the train as prescribed in para 67.

d. Penalties. A penalty of 0.5 point will be assessed if any error is made in preparing the train.

e. Credit. If the test is performed correctly, a maximum credit of 1 point will be awarded.

275. Hydrogen Generator Set AN/TMQ-3 and Sounding Balloon

a. Scope of Test. One test will be conducted in which the candidate will be required to generate the necessary hydrogen gas inflate and shelter a sounding balloon.

b. Special Instructions.

(1) The following equipment will be furnished the candidate:

(a) Eight calcium hydride charges, ML-304A/TM.

(b) One hydrogen generator AN/TMQ-3.

(c) Two sounding balloons.

(d) One balloon nozzle ML-196 and appropriate weights.

(e) Eight calcium hydride charges ML-305A/TM.

(f) One balloon inflation launching device.

(g) One ball twine RP-15.

(h) One pocket knife.

(i) Twenty gallons water.

(k) One FM 6-15.

(l) Grounding equipment, properly installed.

(2) The speed of the winds aloft will be furnished the candidate.

(3) The candidate will be required to assemble the hydrogen generator as part of the test.

(4) The balloons will be conditioned prior to the test, if required.

(5) The inflated balloon will be tied down in a sheltered place for use in a subsequent test.

(6) No penalty will be assessed for balloon breakage unless breakage is caused by carelessness on the part of the candidate. If a balloon is broken through no fault of candidate, time will be started anew on the second balloon.

c. Outline of Test.

Examiner commands—	Action of candidate
GENERATE HYDROGEN AND INFLATE SOUNDING BALLOON.	Assembles the generator and generates the hydrogen gas necessary to inflate a sounding balloon as prescribed in paragraphs 58 through 62. Inflates the balloon.

d. Penalties.

(1) A penalty of 0.7 point will be assessed for each of the following errors:

(a) Inability to assemble the generator set AN/TMQ-3 properly.

(b) Use of an incorrect calcium charge.

(c) Failure to clean the generator properly after inflating the balloon.

(d) Failure to ground nozzle and generator set.

(2) A penalty of 0.5 point will be assessed for each of the following errors:

(a) Failure to clear a constriction in the neck of the balloon which occurs during inflation.

(b) Failure to inspect the inflated balloon for defects.

(c) Failure to inflate the balloon with the correct volume of gas.

(d) Failure to tie the neck of the inflated balloon in such a manner that the balloon is sealed.

(3) Time penalties will be assessed as follows:

Time in minutes, exactly				
or less than	-----	45	50	55 60
Penalties	-----	0	1	2 3

e. *Credit.* If the test is performed correctly within the minimum time limit, a maximum credit of 4 points will be awarded.

276. Baseline Check

a. *Scope of Tests.* Three tests will be conducted in which the candidate will be required to complete the assembly of the radiosonde AN/AMT-4(), tune the rawin set AN/GMD-1(), and perform and evaluate the baseline check at the radiosonde recorder AN/TMQ-5().

b. *Special Instructions.*

(1) The following equipment will be furnished the candidate:

c. *Outline of Tests.*

(a) All equipment used in the tests in paragraphs 271 through 275.

(b) One copy of TM 11-2440.

(c) One computer, humidity-temperature, CP-233B/UM.

(2) All members of the meteorological section will be made available to assist during the tests and will operate the rawin set, radiosonde recorder, or the radiosonde, while the candidate is working on a specific piece of equipment.

(3) Upon completion of test 3, the radiosonde and balloon will be attached to the balloon train in preparation for launching for the next test.

(4) If the humidity element requires replacement, the time required for weathering will not be counted as performance time against the candidate.

Test No.	Examiner commands—	Action of candidate
1	COMPLETE ASSEMBLY OF THE RADIOSONDE AN/AMT-4().	Completes the assembly of the radiosonde by installing the temperature and humidity elements.
2	TUNE RAWIN SET	Tunes the rawin set as prescribed in paragraph 76.
3	PERFORM BASELINE CHECK	Performs and evaluates the baseline check at the radiosonde recorder as prescribed in paragraphs 89, 110.

d. *Penalties.*

(1) *Test 1.* A penalty of 0.5 point will be assessed for each error in completing the assembly of the radiosonde AN/AMT-4().

(2) *Test 2.* A penalty of 1 point will be assessed if the candidate fails to tune the rawin set satisfactorily.

(3) *Test 3.* A penalty of 0.5 point will be assessed for each error in performing and evaluating the baseline check.

(4) *Time penalties.* Time penalties will be assessed as follows:

(a) *Tests 1 and 2.* No time penalties.

(b) *Test 3.*

Time in minutes, exactly or				
less than	--	20	23	26 29 32
Penalties	---	0	0.5	1.0 1.5 2.0

e. *Credit.* Maximum credit of one point each for tests 1 and 2 and 2 points for test 3 will be awarded if the tests are performed correctly. For maximum credit test 3 must be performed within minimum time limits.

277. Operation of Rawin Set AN/GMD-1()

a. *Scope of Test.* One test will be conducted in

which the candidate will be required to operate the rawin set and make the necessary adjustments during the first 5 minutes of a radiosonde ascent.

b. *Special Instructions.*

(1) The equipment listed in previous 6 tests will be made available.

(2) All members of the meteorological section will be made available to assist during the test.

(3) The balloon will train and radiosonde will be launched when the examiner commands WARNING—RELEASE.

(4) The candidate will be instructed to take position as operator of the rawin set to insure that the set is tracking automatically and that necessary adjustments are made.

(5) The remaining members of the meteorological section will perform their normal duties during the ascent except that they will allow the candidate to take over their duties as required by the examiner.

(6) The candidate will not be penalized for the following mishaps:

(a) Balloon burst at or after release.

(b) Signal failure 15 or more minutes after release.

(7) A second radiosonde will be assembled, except for the humidity and temperature elements, for use in event the one prepared by candidate proves defective.

c. Outline of Test.

Examiner commands—	Action of candidate
WARNING-RELEASE	Positions GMD on radiosonde, switches to NEAR-AUTO and FAR-AUTO, and performs necessary checks.

d. Penalties. A penalty of 1 point will be assessed for each of the following errors:

(1) Failure to have the AFC-MANUAL switch in AFC position.

(2) Failure to properly set MANUAL-NEAR AUTO-FAR AUTO switch.

(3) Failure to check that the pin arm is placed in the ON position prior to release.

(4) Failure to perform optical-electrical bearing check.

e. Credit. If the test is performed correctly, a maximum credit of 4 points will be awarded.

278. Obtaining and Evaluating the Radiosonde Record

a. Scope of Test. One test will be conducted in which the candidate will be required to evaluate the radiosonde record and complete DA Form 6-43 (Radiosonde Data).

b. Special Instructions.

(1) The following equipment will be furnished the candidate:

(a) All equipment used in the test in paragraph 277.

(b) One copy of FM 6-16.

(c) One copy of DA Form 6-43 (Radiosonde Data).

(2) The following information will be furnished the candidate:

(a) Baseline and surface observations at release.

(b) Pressure calibration chart.

(c) Radiosonde recorder calibration correction curve.

(3) The candidate will move to the radiosonde recorder and start the test when notified by the examiner. He will operate the radiosonde recorder and perform the evaluating operations during the remainder of the ascent until the examiner gives the command CEASE TRACKING.

(4) The remaining members of the meteo-

rological section will continue to perform their normal duties during an ascent until the command CEASE TRACKING is given.

(5) The candidate will be required to evaluate enough of the record to provide density and temperature data for an eight-line message. The candidate will be instructed to write the reason for putting in each particular level along the line drawn for each significant level.

(6) During the ascent, the control recorder tape with elevation and azimuth angles and reference times will be kept intact so that the candidate can compute winds in a subsequent test.

c. Outline of Test.

Examiner commands—	Action of candidate
EVALUATE RADIO-SONDE RECORD AND COMPLETE DA FORM 6-43 (RADIOSONDE DATA).	Obtains and evaluates the radiosonde record. Completes DA Form 6-43 (Radiosonde Data), as prescribed in para 138.

d. Penalties.

(1) A penalty of 1 point will be assessed insufficient levels are chosen.

(2) A penalty of 0.3 point will be assessed for each of the following errors (total penalties will not exceed 5 points):

(a) Each omission on the radiosonde record.

(b) Each level improperly placed.

(c) Each error in applying calibration or drift corrections in evaluating levels.

(d) Each error of more than ± 0.1 contact in determining contact number for each level.

(3) A penalty of 0.2 point will be assessed for each of the following errors or omissions (total penalties will not exceed 2 points):

(a) Error of ± 1 millibar in determination of pressure from contact numbers.

(b) Error of more than $\pm 0.2^\circ$ C in determination of temperature.

(c) Error of more than ± 2 percent in determination of relative humidity.

e. Credit.

(1) If the test is performed correctly, a maximum credit of 9 points will be awarded.

(2) If total penalties exceed 6 points, no credit will be awarded.

279. Determining Ballistic Densities and Temperatures From Radiosonde Data

a. Scope of Tests. Three tests will be conducted in which the candidate will be required to plot and determine data on chart ML-574/UM and compute ballistic densities and temperatures.

b. Special Instructions.

(1) The following equipment will be furnished the candidate:

- (a) One FM 6-16.
- (b) Two pencils, 3H.
- (c) Eraser.
- (d) Sandboard.
- (e) Chart ML-574/UM.
- (f) One scale ML-573/UM (zone height scale).

c. Outline of Tests.

Test No.	Examiner commands—	Action of candidate
1	PLOT AND DETERMINE DATA ON CHART ML-574/UM.	Plots the points and determines the data as prescribed in para 141.
2	COMPUTE BALLISTIC DENSITIES FOR EIGHT LINES OF MESSAGE TYPE 3.	Computes the ballistic densities as prescribed in para 142, 164.
3	COMPUTE BALLISTIC TEMPERATURES FOR EIGHT LINES OF MESSAGE TYPE 3.	Computes the ballistic temperatures as prescribes in para 143.

d. Penalties.

(1) *Test 1.* A penalty of 0.3 point will be assessed for each of the following errors:

- (a) An error of more than ± 1 millibar in the initial plot of pressure.
- (b) An error of more than $\pm 0.2^\circ$ C in the initial plot of temperature.
- (c) An error of more than ± 2 Gm/m³ in density in the first through the sixth zones.
- (d) An error of more than ± 3 Gm/m³ in density in the seventh and eighth zones.
- (e) An error of more than $\pm 0.5^\circ$ C in temperatures.

(2) *Tests 2 and 3.* A penalty of 0.23 point will be assessed if an error of more than ± 0.1 percent for surface and zones 1 through 8.

(3) *Time Penalties.* Time penalties will be assessed as follows:

(a) *Test 1.*

Time in minutes, exactly or				
less than	20	22	24	26
Penalties	0	1	2	3

(b) *Tests 2 and 3.*

Time in minutes, exactly or				
less than	15	18	21	24
Penalties	0	0.5	1.0	1.5

e. Credit.

(1) If the tests are performed correctly within the minimum time limits, a maximum credit of 3 points for test 1 and 2 points for tests 2 and 3 will be awarded.

(2) If total penalties exceed 4.5 points, no credit will be allowed.

(g) Three copies of DA Form 6-44 (Ballistic Density and Temperature).

(h) One copy of DA Form 6-57 (NATO Metro Message).

(2) The data from DA Form 6-43 (Radio-sonde Data), obtained during the tests conducted under paragraphs 276 and 278 (including level number, pressure (millibars)), temperature (degrees C), and relative humidity (percent) will be furnished the candidate.

280. Determining Zone Winds From Rawin Data

a. Scope of Tests. Three tests will be given which require the candidate to plot a pressure-time curve, determine times at zones, and plot and determine the zone winds.

b. Special Instructions.

(1) The following equipment will be furnished the candidate:

- (a) One plotting board ML-122.
- (b) One rule ML-126A.
- (c) One scale ML-577/UM.
- (d) One slide rule ML-59.
- (e) Two pencils, 3H.
- (f) One art gum eraser.
- (g) One sandboard.
- (h) One copy DA Form 6-49 (Pressure-Time Chart).

(i) One straight edge.

(j) One copy of DA Form 6-46 (Rawin Computation).

(k) One FM 6-16.

(2) The following information will be furnished the candidate:

- (a) Reference pressures from the modulator calibration chart.
- (b) Control recorder tape from the beginning of the ascent.
- (c) Release contact number and release pressure.
- (d) Pressures (mb) at zone heights.
- (e) Surface wind direction and speed.

(3) The candidate will be required to determine the zone winds for an eight-line message.

c. Outline of Tests.

Test No.	Examiner commands—	Action of candidate
1	PLOT THE PRESSURE-TIME CURVE.	Plots the pressure-time curve as prescribed in para 147.
2	DETERMINE THE TIME AT THE ZONE LIMITS.	Determines the time at the zone limits as prescribed in para 147, 167.
3	DETERMINE THE ZONE WINDS.	Determine the zone winds as prescribed in para 147, 167.

d. Penalties.

(1) *Test 1.* A penalty of 0.2 point will be assessed for each error of more than ± 1 millibar in plotting the pressure-time curve.

(2) *Test 2.* A penalty of 0.2 point will be assessed for each error of more than ± 0.2 minute in determining the time at the zone limits.

(3) *Test 3.* A penalty of 0.5 point will be assessed for each error of more than ± 20 mils and each error of more than ± 1 knot in speed of the zone winds.

(4) *Time penalties.* Time penalties will be assessed as follows:

(a) *Test 1.*

Time in minutes, exactly or				
less than	15	18	21	
Penalties	.0	0.5	1.0	

(b) No time penalties will be assessed for test 2.

(c) *Test 3.*

Time in minutes, exactly or								
less than—	25	27	30	33	37	39	42	45
Penalties—	0	1	2	3	4	5	6	7

e. Credit.

(1) If the tests are performed correctly within the minimum time limits, a maximum of 1 point for tests 1 and 2; and 8 points for test 3 will be awarded.

(2) If total penalties exceed 6 points, no credit will be awarded.

281. General and Artillery Meteorology

a. Scope of Test. One test will be conducted in which the candidate will be required to answer orally 30 questions on meteorology.

b. Special Instructions.

(1) The examining officer will read each question through slowly to the candidate two times.

(2) The candidate will be allowed 2 minutes,

if desired, to consider the question, prior to making his answer.

c. Outline of Test.

Examiner commands—	Action of candidate
ANSWER EACH QUESTION ASKED. (Examiner chooses 30 questions from list in <i>d</i> below.)	Answers each question, after due consideration, basing his answers on information in the following official publications: FM 6-15, FM 6-16, TM 11-6660-222-12, TM 11-6660-204-10, TM 11-2602B, TM 11-2413, TM 11-2440, TM 11-2432A, TM 11-6625-213-12, TM 11-6660-206-10, TM 11-6675-200-10, and TM 11-427.

d. Questions.

(1) What are the assumed standards of the meteorological factors on which tables are based?

(2) How does the distance of the point of release from the rawin set (or theodolite) affect the computation of wind speeds?

(3) What devices are used to transmit angular data from the main assembly to the control recorder?

(4) What should the rawin set operator do if the overload indicator flashes on during operation?

(5) Name all rules for evaluating a radiosonde record.

(6) What type of release would you make in a high wind? Why?

(7) What is the purpose of making a baseline check before sending aloft a radiosonde AN/AMT-4()?

(8) What is the humidity tolerance allowed on baseline check for radiosonde AN/AMT-4()?

(9) For what would you look on a radiosonde recorder record if you suspected a frequency shift?

(10) Assuming no abrupt changes of weather (that is, frontal passages), during what hours of the day would you expect to have the highest relative humidity? The lowest relative humidity? Why?

(11) Assuming no abrupt changes of weather (that is, frontal passages) during what hours of the day would you expect to have the highest temperature? The lowest temperature? Why?

(12) What weather changes would you look for at a station to determine whether or not a cold front has passed?

(13) What weather changes would you look

for at a station to determine whether or not a warm front has passed?

(14) What are the disadvantages of using a theodolite and a pilot balloon to determine winds aloft? What are the advantages?

(15) Why are ballistic densities computed by the departure method often inaccurate?

(16) A sound ranging message is computed at 0200 hours (sunrise 0600, sunset 1800). What is the correction for time of day if there is no rain, drizzle, or fog?

(17) Why is humidity not evaluated on a radiosonde record when the radiosonde reaches 105 contacts?

(18) On chart ML-574/UM you divide the virtual temperature sounding curve into artillery zones by balancing areas with your zone height scale. Why?

(19) Give specific reasons why it is important to check leveling on a theodolite or rawin set before releasing a balloon?

(20) How would you check the optical-electrical bearing on the rawin set?

(21) For winds only, why are the surface and first line zone winds also considered ballistic winds?

(22) Why are winds normally more constant in the upper air rather than at or near the surface?

(23) What factors determine the thickness in meters of a layer of air 100 millibars thick?

(24) Describe the two fundamental types of clouds and name at least one cloud from each of the three height classifications.

(25) Where is the stratosphere located?

(26) Density is computed from pressure, temperature, and humidity. How does variation of any one element, in turn, affect the density?

(27) List six elements of weather.

(28) What is the meaning of the term "sonic temperature"?

(29) What type of signal is transmitted by the radiosonde AN/AMT-4()?

(30) What are the component parts of the radiosonde AN/AMT-4()?

(31) Describe the operation of the recorder mechanism in a radiosonde recorder AN/TMQ-5().

(32) Explain how wind can effect a projectile during its trajectory.

(33) What is the purpose of the detector in the radiosonde recorder AN/TMQ-5()?

(34) Diagram a commutator bar from a radiosonde modulator between the 55th and 65th contacts, indicating what each segment represents.

(35) What are the condensation nuclei?

(36) Describe an occluded front.

(37) What is an isotherm, isobar, and millibar?

(38) Define ICAO.

(39) What is the standard condition for temperature, in percent, for artillery zone eight?

(40) What is the proper name of the deflective force caused by the rotation of the earth and what effect does it have on the winds?

(41) What is the zone structure for radiological fallout computations?

(42) What is the zone structure for computer messages?

(43) In what units are wind direction, wind speed, temperature, and density reported on a computer met message?

(44) What meteorological data are required on a fallout met message?

(45) What meteorological data are reported for significant levels when exchanging data with Air Weather Service?

(46) In what units and to what accuracy are wind data reported for Air Weather Service exchange?

e. Penalties. A penalty of 0.6 point will be assessed for each question that is not answered, or is answered incorrectly.

f. Credit.

(1) If the test is performed correctly, a maximum credit of 18 points will be awarded.

(2) If total penalties exceed 12 points, no credit will be awarded.

APPENDIX A

REFERENCES

1. Publication Indexes

Department of the Army Pamphlets of the 310-series should be consulted frequently for latest changes or revisions of references given in this appendix and for new publications relating to material covered in this manual.

2. Army Regulations

AR 115-10/AFR 105-3	Meteorological Support for the U.S. Army.
AR 310-25	Dictionary of United States Army Terms.
AR 310-50	Authorized Abbreviations and Brevity Codes.
AR 700-75	Logistics (General), Use of Metric Units of Measurement in United States Army Weapons.
AR 750-8	Command Maintenance Management Inspections (CMMI).

3. Department of the Army Pamphlets

DA Pam 108-1	Index of Army Motion Pictures and Related Audio-Visual Aids.
DA Pam 310-series	Military Publications Indexes (as applicable).
DA Pam 750-1	Preventive Maintenance Guide for Commanders.

4. Field Manuals

FM 5-20	Camouflage.
FM 6-2	Artillery Survey.
FM 6-10	Field Artillery Communications.
FM 6-16	Tables for Artillery Meteorology.
FM 6-40	Field Artillery Cannon Gunnery.
FM 6-40-1	Field Artillery Honest John/Little John Rocket Gunnery.
FM 6-61	Field Artillery Battalion, Honest John.
FM 6-120	Field Artillery Target Acquisition Battalion and Batteries.
FM 6-122	Artillery Sound Ranging and Flash Ranging.
FM 21-5	Military Training Management.
FM 21-6	Techniques of Military Instruction.
FM 21-26	Map Reading.
FM 21-30	Military Symbols.
FM 21-40	Chemical, Biological, Radiological, and Nuclear Defense.
FM 31-25	Desert Operations.
FM 31-35	Jungle Operations.
FM 31-70	Basic Cold Weather Manual.
FM 31-71	Northern Operations.
FM 100-5	Operations of Army Forces in the Field.

5. Technical Manuals

TM 3-210	Fallout Prediction.
TM 3-220	Chemical, Biological, and Radiological (CBR) Decontamination.
TM 5-230	General Drafting.
TM 5-6115-232-10	Operators Manual, Generator Set, 10-kw (Hol-Gar).
TM 5-6115-232-20P	Organizational Maintenance Repair Parts and Special Tool Lists, Generator Set, 10-kw (Hol-Gar).

TM 6-230	Logarithmic and Mathematical Tables.
TM 6-240	Slide Rule, Military, Field Artillery.
TM 11-427	Barometers ML-102() and ML-316/TM.
TM 11-661	Electrical Fundamentals (DC).
TM 11-681	Electrical Fundamentals (AC).
TM 11-2413	Hydrogen Generator ML-303/TM and Hydrogen Generator Set AN/TMQ-3.
TM 11-2421	Barometers ML-331/TM, ML-332/TM, ML-333/TM, and Mercurial Barometers ML-330/FM and ML-330A/FM.
TM 11-2432A	Radiosondes AN/AMT-4A, AN/AMT-4B, AN/AMT-4C, and Radiosonde Set AN/AMT-4D.
TM 11-2440	Radiosonde Baseline Check Sets AN/GMM-1().
TM 11-2442	Plotting Board ML-122.
TM 11-2602B	Frequency Standards TS-65C/FMQ-1 and TS-65D/FMQ-1.
TM 11-6625-213-12	Operator and Organizational Maintenance Manual: Test Sets TS-538/U, TS-538A/U, TS-538B/U, and TS-538C/U.
TM 11-6625-213-20P	Organizational Maintenance Repair Parts and Special Tools Lists: Test Sets TS-538/U, TS-538A/U, TS-538B/U, and TS-538C/U.
TM 11-5805-201-12 and -35	Telephone Set TA-312/PT.
TM 11-6625-239-12	Operator's and Organizational Maintenance Manual: Electronic Multi-meters TS-505()/U.
TM 11-6625-274-12	Operator's and Organizational Maintenance Manual for Test Set, Electron Tube TV-7/U.
TM 11-6625-274-25P	Organizational DS, GS, and Depot Maintenance Repair Parts and Special Tools Lists for Test Set, Electron Tube TV-7()/U.
TM 11-6625-407-20P	Organizational Maintenance Repair Parts and Special Tool Lists: Frequency Standards TS-65()/FMQ-1.
TM 11-6660-203-10	Operator's Manual: Wind Measuring Sets AN/MMQ-1, AN/MMQ-1A, AN/MMQ-1B, and AN/PMQ-6.
TM 11-6660-203-20	Organizational Maintenance Manual: Wind Measuring Sets AN/MMQ-1, AN/MMQ-1A, AN/MMQ-1B, and AN/PMQ-6.
TM 11-6660-203-20P	Organizational Maintenance Repair Parts and Special Tools Lists: Wind Measuring Sets AN/MMQ-1 and AN/MMQ-1A, AN/MMQ-1B, and AN/PMQ-6.
TM 11-6660-204-10	Operator's Manual: Radiosonde Recorders AN/TMQ-5, -5A, -5B, and -5C.
TM 11-6660-204-10P	Operator's Maintenance Repair Parts and Special Tools Lists: Radiosonde Recorders, AN/TMQ-5, AN/TMQ-5A, AN/TMQ-5B, and AN/TMQ-5C.
TM 11-6660-206-10	Operator's Manual, Rawin Sets AN/GMD-1, and 1B.
TM 11-6660-206-20	Organizational Maintenance Manual: Rawin Sets AN/GMD-1A, and 1B.
TM 11-6660-206-20P	Organizational Maintenance Repair Parts and Special Tool Lists: Rawin Sets AN/GMD-1, -1A, and -1B.
TM 11-6660-218-12	Organizational Maintenance Manual: Meteorological Station Manual AN/TMQ-4.
TM 11-6660-218-25P	Organizational, Field and Depot Maintenance, Repair Parts, and Special Tool Lists for Meteorological Station, Manual AN/TMQ-4.
TM 11-6660-219-12	Operator and Organizational Maintenance Manual: Radiosonde Baseline Check Sets AN/GMM-1, AN/GMM-1A.
TM 11-6660-219-20P	Organizational Maintenance Repair Parts and Special Tool List: Radiosonde Baseline Check Sets AN/GMM-1, AN/GMM-1A.
TM 11-6660-220-10	Operator's Manual: Radiosonde Sets AN/AMT-12 and AN/AMT-12A.
TM 11-6660-222-12	Operator and Organizational Maintenance Manual: Meteorological Balloons Thermometers ML-4, -5 and -7; Psychrometers ML-24 and ML-

- 224; Instrument Shelter, Meteorological S-101/UM; Support, Instrument Shelter, MT-1426/UM and Launching Equipments.
1426/UM and Launching Equipments.
- ★TM 11-6660-238-15 Organizational, DS, GS and Depot Maintenance Manual: Balloon Inflation and Launching Device ML-594/U.
- ★TM 11-6660-238-25P Organizational, DS, GS and Depot Maintenance Repair Parts and Special Tools List: Balloon Inflation and Launching Device ML-594/U.
- ★TM 11-6660-245-15 Organizational, DS, GS and Depot Maintenance Manual: Meter, Volume, Hydrogen—Helium ML-605/U.
- ★TM 11-6660-245-25P Organizational, DS, GS and Depot Maintenance Repair Parts on Special Tools List: Meter, Volume, Hydrogen—Helium ML-605/U.
- TM 11-6675-200-20 Organizational Maintenance Manual: Theodolites ML-47C through ML-47R, ML-247 and ML-247A, and Double Center Theodolite ML-474/GM and ML-47A/GM.
- TM 11-6675-200-10 Operator's Manual: Theodolites ML-47C through ML-47R, ML-247 and ML-247A, and Double Center Theodolite ML-474/GM and ML-474A/GM.
- TM 11-6685-202-12P Operator's and Organizational Maintenance Repair Parts and Special Tool Lists for Barometers ML-102B, -D, -E, -F, and -G.

6. Blank Forms

- DA Form 6-42 Ballistic Winds From Observations of 30- and 100-Gram Balloons.
DA Form 6-43 Radiosonde Data.
DA Form 6-44 Ballistic Density or Temperature.
DA Form 6-46 Rawin Computation.
DA Form 6-48 Weather Data for Sound Ranging.
DA Form 6-49 Pressure-Time Chart.
DA Form 6-50 Ballistic Density From Surface Data.
DA Form 3675 Ballistic Met Message.
DA Form 3676 Fallout Met Message.
DA Form 3677 Computer Met Message.
DA Form 3583 Meteorological Data for Artillery-Air Weather Service Exchange.

7. Miscellaneous Publications

- SEATO SEASTAG 2029, Method of Locating Ground Locations, Areas and Boundaries.
NATO STANAG 4044, Standard Atmosphere for Ballistic Purposes.
NATO STANAG 4061, Adoption of a Standard Ballistic Met Message.
★NATO STANAG 4082, Adoption of a Standard Artillery Computer Meteorological Message.
NATO STANAG 4103, Requests for Meteorological Messages for Ballistic Purposes.
★FMH #1—Surface observations.
★FMH #3—Radiosonde Observations.
FT 155—AH-2, Firing Tables for Cannon, 155mm Howitzer.
TB Med 175—The Etiology, Prevention, Diagnosis and Treatment of Adverse Effects of Heat.
Report—NATO Ninth General Conference on Weights and Measures (1948).
Report—Number 1235, National Advisory Committee for Aeronautics.
Report—U.S. Extension to the ICAO Standard Atmosphere, Geographics Research Directorate and Weather Bureau, U.S. Department of Commerce.
Glossary of Meteorology (1959).
Manual of Winds-Aloft Observation (WBAN) Circular O.
AWSM 105-17—Exchange of Rawinsonde Data (AWS—Artillery Meteorological Section) 2 July 1970.

APPENDIX B

INSPECTION CHECKLISTS

1. Purpose

The purpose of this appendix is to relate the material presented in the text to inspections and inspection checklists.

2. Checklist for Command Maintenance Inspection

The following inspection checklist for signal corps equipment is used by major commanders and signal corps spot check teams to inspect organizational maintenance and related supply facilities during command maintenance inspections:

ORGANIZATIONAL MAINTENANCE FACILITIES, PROCEDURES CHECKLIST

Yes	No	
_____	_____	1. Are operator maintenance checklists satisfactory?
_____	_____	2. Is organizational maintenance checklist file satisfactory?
_____	_____	3. Is adequate time allowed for preventive maintenance inspections?
_____	_____	4. Are preventive maintenance inspections performed periodically under proper supervision?
_____	_____	5. Are safety rules and regulations complied with on maintenance operations?
_____	_____	6. Is prompt action taken to correct shortcomings disclosed by higher echelon of maintenance?
_____	_____	7. Are repair techniques satisfactory?
_____	_____	8. Is prompt action taken to evacuate equipment requiring a higher echelon of maintenance?
_____	_____	9. Are equipment running spares on hand?
_____	_____	10. Are required repair parts on hand, if authorized?
_____	_____	11. Are repair parts properly stored and location known?
_____	_____	12. Are repair parts used discriminately as determined by condition of part replaced?
_____	_____	13. Are repair parts for unserviceable equipment (requiring organizational maintenance) on requisition?
_____	_____	14. Are required tools available, if authorized?
_____	_____	15. Is required test equipment available, if authorized?
_____	_____	16. Are tools and test equipment properly cleaned and stored when not in use?
_____	_____	17. Are unserviceable tools turned in for repair or replacement?
_____	_____	18. Are DA lubrication orders on hand and used?
_____	_____	19. Are technical manuals including published changes on hand for each type of equipment?
_____	_____	20. Are technical manuals and supply bulletins used in performing maintenance inspections and services?
_____	_____	21. Are files of supply bulletins, technical bulletins, signal supply manuals, etc, satisfactory?
_____	_____	22. Is signal equipment used properly?
_____	_____	23. Is proficiency of maintenance personnel adequate?

INSTRUCTIONS FOR DETERMINING RATING:

Certain questions may not be applicable to all units inspected; therefore, to obtain a correct rating, divide the number of positive answers by the number of applicable questions and multiply the answer by 100 to obtain a percentage figure.

RATING

INSPECTOR

3. Checklist for Spot Check Inspection

The following inspection checklist for Signal Corps equipment is used by Signal Corps spot check teams at division or higher level to determine minor shortcomings:

INSPECTION OF THE ORGANIZATION FACILITIES

Yes	No	
_____	_____	1. Are operator maintenance checklists on hand and being used?
_____	_____	2. Is adequate time allowed for preventive maintenance inspections?
_____	_____	3. Are preventive maintenance inspections performed periodically under proper supervision?
_____	_____	4. Is prompt action taken to correct shortcomings disclosed by maintenance inspections?
_____	_____	5. Are equipment running spares on hand?
_____	_____	6. Are required repair parts on hand, if authorized?
_____	_____	7. Are repair parts used discriminately as determined by condition of part replaced?
_____	_____	8. Does unit comply with provisions of paragraph 3c, AR 750-5?
_____	_____	9. Are tools and test equipment properly cleaned and stored when not in use?
_____	_____	10. Are Department of the Army lubrication orders on hand and used?
_____	_____	11. Are technical manuals including published changes on hand for each item of equipment?
_____	_____	12. Are technical manuals and supply bulletin used in performing maintenance inspections and services?
_____	_____	13. Are files of supply bulletins, technical bulletins, signal supply manuals, etc, satisfactory?
_____	_____	14. Is test equipment used properly?

Certain questions may not be applicable to all units inspected; therefore, to obtain a correct rating, divide the number of positive answers by the number of applicable questions, and multiply the answer by 100 to obtain a percentage figure.

RATING INSPECTOR

4. Checklist for Inspection of Meteorological Section

The following checklists are used by commanders inspecting the meteorological section.

COMMANDER'S CHECKLIST FOR MET SECTIONS

Satisfactory	Unsatisfactory	<i>Equipment</i>
_____	_____	1. Is the rawin set level? (Check leveling bubbles on side of receiver housing.)
_____	_____	2. Is the rawin set properly oriented? (Have the operator position the antenna on the orienting point. Read azimuth and elevation dials on the rawin set and on control-recorder.)
_____	_____	3. Is the control-recorder properly synchronized? (Have the operator position the rawin set on the orienting point. Have the operator place the RECORDS CONTROL switch on the control-recorder to the FLIGHT position. The set should print the orienting azimuth and elevation angles on the paper tape. Time should read 000 on initial print.)
_____	_____	4. Is the radiosonde recorder AN/TMQ-5 properly adjusted for flight? (Check the frequency meter on the front panel for 60 hertz. Check a flight record to see that the recorder pen is adjusted to mark a fine, legible trace on the paper chart. Have the operator depress the RECORDER TEST switch. Pen should move to 95 recorder divisions and mark on the chart paper. At the same time, the control-recorder should print the time with an asterisk (*).)
_____	_____	5. Is the gasoline-powered generating equipment in good operating condition? (Check control panel on unit. Frequency dial should show 60 to 62 hertz. Voltage output indicator should show 120 volts.)
_____	_____	6. Are the section vehicles in good operating condition?
_____	_____	7. Is the theodolite declinated?
_____	_____	8. Is there a maintenance log on the rawin set and radiosonde recorder?
_____	_____	9. Is the plotting equipment clean, legible, and serviceable?
_____	_____	10. Is the wick on the psychrometer clean?
_____	_____	11. During a radiosonde flight is the telescope "on target" and tracking smoothly?
Satisfactory	Unsatisfactory	<i>Operations</i>
_____	_____	1. Is the station altitude correct?
_____	_____	2. Does the section keep a file of flight records?
_____	_____	3. Is a calibration correction chart posted on or near the radiosonde recorder AN/TMQ-5?
_____	_____	4. Are balloons "conditioned" before a flight? (Balloons more than one year old need conditioning).

Satisfactory	Unsatisfactory

5. Is the barometer checked against a standard barometer at least every 90 days? Last date checked? _____.
6. Does the section operate on an assigned radiosonde frequency? _____ megahertz.
7. Is the chief of section employing a method of checking each individual's work?
8. Is a training program being implemented by the section? (On the job and/or formal.)
9. Are duties rotated in the section to insure flexibility in operation?
10. Is a qualified maintenance man assigned to the section?
11. Is the authorized level of expendables (_____ days supply) on hand?
12. Is a complete set of publications pertaining to meteorological equipment on hand?
13. Are 3H or harder pencils utilized for plotting and are charts and plots neat and legible? (Look at flight records.)
14. Have adequate radio and wire communications been established to facilitate operation and transmission of metro data?
15. Are section weapons properly integrated into the local security plan? (This includes individual weapons in addition to any others the section may have.)

Satisfactory	Unsatisfactory

Site

1. Was local security considered when the site was selected?
2. Are all safety procedures observed during inflation of balloons with hydrogen gas? (NO SMOKING signs placed at least 15 meters from inflation area; grounding equipment in place on hydrogen generating equipment (fig. 35).)
3. If operating in the field with calcium hydride, is there a nearby source of water? If not, has provision been made for obtaining an adequate supply of water?

Satisfactory	Unsatisfactory

Personnel

1. Are personnel neat and courteous?
2. Is 50 percent of section personnel school trained?
3. Do all assigned individuals participate in the section training?
4. Is the met warrant officer trained in maintenance?
5. Is the station chief trained in maintenance?

Date _____
 Name _____

Comments: _____

GLOSSARY

ABBREVIATIONS AND DEFINITIONS

Section I. ABBREVIATIONS

The following abbreviations and terms appear throughout this manual. An understanding of them is necessary for a proper understanding of the subject matter contained herein.

AWS—Air Weather Service.
 CBR—Chemical, biological, radiological.
 GMT—Greenwich mean time.
 ICAO—International Civil Aviation Organization.
 MDP—Meteorological datum plane.
 NATO—North Atlantic Treaty Organization.
 RATT—Radio teletypewriter.
 SOLOG—Standardization of certain aspects of

operations and logistics (among Quadripartite nations).

SWO—Staff weather officer, member of the Air Force, Air Weather Service.

STANAG—Standardization Agreements (among NATO nations).

STRAC—United States Strategic Army Corps.

WBAN—(Weather Bureau, Air Force, Navy) A series of weather observation manuals. The manual covering radiosonde observations is WBAN Circular P.

WMO—World Meteorological Organization.

Section II. DEFINITIONS

Advection—The process of transport of an atmospheric property solely by the mass motion of the atmosphere, normally in the horizontal direction.

Air mass—An extensive body of air within which the conditions of temperature and moisture in a horizontal plane are essentially uniform.

Albedo—The ratio of electromagnetic radiation reflected by a body to the amount incident upon it, commonly expressed as a percentage.

All-weather—The ability to be functional without regard to weather.

Ambient temperature—The temperature of the immediate surrounding medium, such as a gas or liquid.

Anemometer—The general name for instruments designed to measure the speed (or force) of the wind.

Aneroid—Literally, "not wet," containing no liquid; applied to a kind of barometer which contains no liquid, an aneroid barometer.

Ballistic meteorology—The study dealing with the phenomena of the atmosphere and its effect upon the motion of a projectile.

Ballistics—The science of the motion of projectiles.

Barometer—An instrument for measuring atmospheric pressure.

Baseline check—The procedure by which an equivalence is established between recorder division values and measured values of temperature and humidity.

Celsius—A temperature scale which uses 0 as the ice point and 100° as the boiling point. The same as Centigrade.

Cirrus—A principal cloud type composed of detached cirriform elements (mostly ice crystals fairly widely dispersed) in the form of white, delicate filaments of white (or mostly white) patches or of narrow bands.

Climatological information—That information which deals with weather conditions and variations from normal, for a particular place or area, during a specified period of the year.

Command post—A unit's or subunit's headquarters where the commander and the staff perform their activities.

Condensation—In meteorology, the physical process by which water vapor is changed to liquid water.

Condensation nuclei—A minute particle, either liquid or solid, upon which condensation of water vapor begins in the atmosphere.

Conduction—The transmission of energy within a substance by means of internal molecular ac-

- tivity, and without any net external motion of the substance.
- Convection*—Atmospheric motions that are predominantly vertical, resulting in vertical transport and mixing of atmospheric properties; distinguished from advection.
- Coriolis force*—An apparent force which causes moving particles to be deflected to the right in the Northern Hemisphere and to the left in the Southern Hemisphere.
- Critical angle*—The limiting angle at which angular data becomes invalid. For rawinsonde data, the critical angle is an angle of 6 degrees.
- Cumuliform*—Like cumulus; generally descriptive of all clouds, the principal characteristic of which is vertical development in the form of rising mounds, domes, or towers. Contrasting to stratiform.
- Cursor*—The runner. On a slide rule, the sliding index. On a humidity-temperature computer, the free turning temperature index.
- Departure method*—The method of predicting ballistic densities by use of a measured surface density and the "Departures from mean surface density" tables of FM 6-16, "Tables for Artillery Meteorology."
- Dewpoint temperature*—The temperature to which air must be cooled in order to cause saturation.
- DI, Discomfort Index*—The temperature-humidity index, specified by the U.S. Weather Bureau, used to report the relative discomfort due to heat.
- Diurnal*—Daily variation of actions which recur every twenty-four hours.
- Doldrums*—A nautical term for the equatorial trough, with special reference to the light and variable nature of the winds.
- D region*—The lowest ionized layer of the atmosphere which attenuates and reflects low frequency radio waves.
- Effective temperature*—The temperature used in computing corrections for sound ranging, the sonic temperature.
- Ephemeris*—Tabular statement of the assigned places of celestial bodies for regular intervals.
- Equation of state*—An equation relating temperature, pressure, and volume of a system in thermodynamic equilibrium.
- Evaporation*—The physical process by which liquid water is changed to water vapor.
- Exosphere*—The outermost layer of the earth's atmosphere.
- Fallout*—The precipitation to earth of particulate matter from a nuclear cloud; also applied to the matter itself which may or may not be radioactive.
- Free rocket*—Any unguided rocket.
- Fronts*—In general, a transition zone between air masses of different densities.
- Geostrophic wind*—The wind which occurs when the pressure gradient force balances the coriolis force and friction is disregarded.
- Heat of fusion*—The heat released by a fluid when it changes from liquid to solid.
- Horizontal distance*—The arc distance or the distance traveled by a balloon as projected to the earth's curved surface.
- Humidity-temperature computer*—A special circular slide rule used to compute radiosonde temperature and humidity from radiosonde recorder record values.
- Hydrostatic equation*—The basic force equation which states that the change of pressure with respect to height is equal to the negative product of density and the acceleration of gravity.
- Hygristor*—A humidity sensing element or device. A resistor whose resistance varies according to the amount of humidity in the air.
- Hypsometer*—An instrument for measuring height: specifically, an instrument for measuring atmospheric pressure by determining the boiling point of a liquid.
- Inversion*—A layer of atmosphere where the temperature increases rather than decreases with height.
- Isobar*—A line of constant pressure.
- Isobaric*—Of equal or constant pressure.
- Isotherm*—A line of constant temperature.
- Isothermal*—Of equal or constant temperature.
- Isopycnic*—A line of constant density.
- Jet stream*—Relatively strong winds concentrated within a narrow stream in the atmosphere. While this term may be applied to any such stream regardless of direction, it is coming more and more to mean only a quasi-horizontal jet stream of maximum winds in the high troposphere in the midlatitude westerlies.
- Kelvin scale (°K)*—An absolute temperature scale with an ice point of 273.16° K and a boiling point of 373.16°.
- Lapse rate*—The rate at which temperature decreases with altitude.
- Low-level winds*—Winds in the friction layer of the atmosphere.
- Magnetic declination*—The angle between true north and magnetic north.
- Mean sea level pressure*—Station pressure reduced to mean sea level pressure.
- Mean sea level*—The average height of the sea

- surface, based upon hourly observation of tide height on the open coast or in adjacent waters which have free access to the sea.
- Mesopause*—The top of the mesosphere.
- Mesosphere*—The layer of the atmosphere immediately above the stratopause.
- Met*—A contraction of meteorology.
- Meteorological day*—A 24-hour day divided into three periods: the night period, the afternoon period, and the transition period.
- Meteorological information*—Information concerned with the phenomena of the atmosphere. Data pertaining to the atmosphere, especially wind, temperatures, and air density, which are used in ballistics.
- Meteorology*—The science of the earth's atmosphere.
- Micrometeorology*—That branch of meteorology that deals with the observation and explanation of the smallest-scale phenomena within the atmosphere.
- Millibar (mb)*—A unit of pressure, convenient for measuring atmospheric pressure, which is equal to a force of 1000 dynes per square centimeter.
- Modulator*—That part of a radiosonde which contains the sensing elements and baroswitch.
- Monsoon*—Seasonal wind systems which derive their energy from land and water temperature differences.
- Neoprene*—A synthetic rubber-like plastic material.
- Noctilucent clouds*—Clouds, believed to be composed of either cosmic dust or water droplets, which occur at an altitude of approximately 82 kilometers.
- Occlusion*—An occluded front. A composite of two fronts, formed as a cold front, overtakes a warm front or quasi-stationary front.
- Offset*—The difference in distance and the azimuth from an observing point to the point of release of a sounding or pilot balloon.
- Orographic*—Of, pertaining to, or (frequently in meteorology) caused by mountains.
- Ozone*—A faintly blue, gaseous form of oxygen which exists in the atmosphere.
- Panoramic telescope*—The on-carriage optical sight used to lay an artillery weapon for direction.
- Parameter*—A quantity to which arbitrary values may be assigned such as in a mathematical problem.
- Polar easterlies*—The dominant wind system which exists in polar regions.
- Pilot balloon*—A small balloon whose ascent is followed by a theodolite in order to obtain data for the computation of the speed and direction of winds in the upper air.
- Polarization*—An electro-chemical effect which causes the electrical resistance of a lithium chloride humidity element to vary slightly when a voltage is applied to the element.
- Precipitation*—A form of water, either liquid or solid, that falls from the atmosphere and reaches the ground.
- Pressure gradient force*—The force due to pressure differences within a fluid mass.
- Prevailing westerlies*—The dominant wind system of the atmosphere which occurs in middle latitudes of both hemispheres.
- Prognostic chart*—A chart showing, principally, the expected pressure pattern of a given synoptic chart at a specified future time.
- Projectile*—A body projected by exterior force and continuing in motion by its own inertia.
- Psychrometer*—An instrument used for determining the water vapor content of the atmosphere.
- Radiation*—The process by which electromagnetic energy is propagated through free space.
- Radioactive fallout*—The eventual descent to the earth's surface of radioactive matter placed in the atmosphere by atomic or thermonuclear explosion. Also called radiological fallout.
- Radiosonde*—A balloon-borne instrument for simultaneous measurement and transmission of meteorological data.
- Radiological fallout*—See radioactive fallout.
- Rawinsonde*—(radiosonde and radar wind sounding (Combined))—A method of upper air observation consisting of the evaluation of winds, temperature, pressure, and relative humidity aloft by means of a balloon-borne radiosonde tracked by a radio direction finder.
- Rawin*—A method of winds aloft observation; that is, the determination of wind speed and direction in the atmosphere above the station.
- Relative humidity*—The ratio of the actual vapor pressure of the air to the saturation vapor pressure, usually expressed in percent.
- Significant level*—A level in the atmosphere usually selected as the result of a change in the rate of change of temperature or humidity with height. The location of the points of evaluation of the radiosonde record.
- Sonic temperature*—The temperature used in computing corrections for sound ranging, the effective temperature.
- Sound ranging (sound locating)*—The method of locating the source of a sound, such as that of a

- gun report or a shell burst, by calculations based on the intervals between the reception of the sound at various previously oriented microphone stations.
- Sounding balloon*—A free, unmanned balloon used for sounding the upper air.
- Source region*—An extensive portion of the earth's surface whose temperature and moisture properties are fairly uniform.
- Standard altitude*—The height above surface of the top of a prescribed standard zone.
- Standard ballistic density*—The density of the air as defined by the ICAO standard atmosphere. A density of 100 percent.
- Station model*—A specified pattern for entering, on a synoptic chart, the meteorological symbols which represent the state of the atmosphere at a particular station.
- Station pressure*—Surface pressure at the observing station. The atmospheric pressure computed for the level of the station elevation.
- Stratiform*—Description of clouds of extensive horizontal development, as contrasted to the vertically developed cumuliform types.
- Stratopause*—The top of the stratosphere.
- Stratosphere*—The layer of atmosphere immediately above the tropopause.
- Supercooled*—The reduction of temperature of any liquid below the melting point of that substance's solid phase; that is, cooled beyond its nominal freezing point.
- Surface wind*—The wind speed and direction as measured at the surface with an anemometer or the wind speed and direction detected by a 15 second flight of a 30-gram pilot balloon (10 sec flight of a 100-gram balloon).
- Synoptic weather*—Refers to the use of meteorological data obtained simultaneously over an extensive area for the purpose of presenting a comprehensive picture of the state of the atmosphere.
- Temperature-humidity computer*—A special circular slide rule used to convert radiosonde recorder record values to values of temperature and relative humidity.
- Thermistor temperature*—The temperature measured by the temperature element (thermistor) on a radiosonde.
- Terrestrial*—Pertaining to the earth.
- Theodolite*—An instrument which consists of a sighting telescope and graduated scales to read angles of azimuth and elevations.
- Thermosphere*—The layer of atmosphere immediately above the mesopause.
- Trade winds*—The wind system, occupying most of the tropics, which blows from the subtropical highs toward the equatorial trough.
- Trajectory*—The path of a projectile in the earth's atmosphere.
- Tropopause*—The top of the troposphere.
- Tropopause*—The top of the troposphere. from the earth's surface to the tropopause (10 to 20 km) in which the average condition is typified by a decrease of temperature with increasing altitude.
- True north*—The direction from any point on the earth's surface toward the geographic North Pole.
- Topography*—Generally, the disposition of the major natural and man-made physical features on the earth's surface.
- Turbulence*—Irregular motion of the atmosphere, which defies analytical representation, such as when air flows over uneven surfaces of the earth.
- Visual technique*—The determination of upper air conditions from pilot balloon observations and the measurement of surface temperature, pressure, and relative humidity.
- Virtual temperature*—In a system of moist air, the temperature of dry air having the same density and pressure as the moist air. The virtual temperature is always greater than the actual temperature.
- WBGT index*—A temperature-humidity index, specified by the American Society of Heating and Ventilating Engineers, used to report the relative discomfort due to heat.
- Weather forecast*—A prediction of expected weather conditions at a point, along a route, or within an area, for a given time or specific period of time in the future.
- Weather information*—Information concerning the state of the atmosphere, mainly with respect to its effects upon the military. Data and information concerned with forecasts, summaries, and climatology. Data and information normally associated with the activities of the Air Weather Service.
- Weather radar*—Radar, such as the AN/TPS-41, designed and used for tracking and detecting storm clouds.
- Weighting factors*—The factors used in weighting the effects of met conditions in each artillery zone.
- Wet-bulb depression*—The difference in degrees between the dry-bulb temperature and the wet-bulb temperature.
- Wind chill*—That part of the total cooling of a body caused by air motion.

Wind shear—The local variation of the wind vector or any of its components in a given direc-

tion.

Zone wind—The average wind within a zone.

INDEX

	Paragraph	Page		Paragraph	Page
Action upon receipt of fallout met message	188	209	Balloons:		
Air masses:			General	62	60
Classification	17	15	Pilot, night lighting units ..	65	64
General	15	15	Preparation of trains	67	65
Source regions	16	15	Sounding, determining inflation volume and lift ...	66	64
Air Weather Service:			Baseline check:		
Forecasts available	212	228	Evaluation	111	105
General	27	30	Radiosonde and sensing elements	110	102
Manning charts	209	223	Validity	113	107
Organization for army support	208	222	Biological and radiological agents, decontamination	249	263
Special forecast and climatology	213	229	Bracket, assembly, antibouyancy ..	61	60
Allied nations met message service	37	37	Calcium hydride charges	59	59
Anemometers	49, 223	51, 239	Calibration, radiosonde recorder ..	86	83
Application of rules for selecting significant levels	128	114	Capabilities of artillery met section	33	35
Arctic operations:			Character of weather services ..	207	222
General	225	247	Characteristics of fronts	18	16
Operational procedures and maintenance	226	247	Charges, calcium hydride	59	59
Artillery:			Chart ML-574/UM :		
Met Application of message from AWS	219	233	Balancing areas	140	144
Met section, organization ..	29	32	Evaluating temperature, density and pressure	141	146
Met staff officer	32	34	Chart, synoptic	22	21
Artillery met messages:			Charts:		
Space validity when using pilot balloon	171	195	Air weather support of a type field army	209	223
Time validity when using pilot balloon	172	195	Army—tactical weather sta- tion (augmented)	209	223
Validity, general	170	195	Army—additional augmentation	209	223
Assembly:			Corps—tactical weather station	209	223
Bracket, antibouyancy	61	60	Division—tactical weather station (reduced)	209	223
And electrical test of radiosonde	108	101	Checklists for inspections	App B	284
Atmosphere:			Chemical agents, decontamination ..	248	263
Composition of earth's	7	5	Circulation, air	14	11
Transfer of heat in	9	7	Classification of air masses	17	15
Vertical structure	8	5	Clouds	13	10
Atmospheric pressure	10	8	Code:		
Balancing areas on chart ML-574/UM	140	144	Computer message	156	169
Ballistic density	165	180	NATO message	153	164
Ballistic meteorology	23, 24	24	Synoptic	20	21
Ballistic Winds:			Command maintenance inspec- tions	238	255
Determining	169	188	Comparison of surface observa- tion data with electronic data ..	187	209
Obtaining with pilot balloon ..	151	160	Completed sound ranging message	181	203
Balloon inflation launching device	55	56			

	Paragraph	Page		Paragraph	Page
Completion of:			Destruction of equipment:		
DA Form 6-43 (Radiosonde Data)	138	135	General	250	264
Fallout wind data	195	211	Methods	252	264
Composition of earth's atmosphere	7	5	Principles	251	264
Computation of:			Determination of:		
Artillery zone temperature and density	220	233	Fallout zones on chart		
Ballistic density	144	149	ML-574/UM	194	211
Ballistic temperature	143	148	Inflation volume and lift for sounding balloons	66	64
Temperature and humidity index	233	251	Zone winds for computer and NATO met message prepared concurrently	148	158
Zone winds	221	233	Determining:		
Computer, humidity-temperature	112	106	Ballistic winds for a NATO met message	151	160
Computer message:			Mean zone densities and temperatures from radiosonde data	139	140
Code	156	169	Validity of baseline check	113	107
Encoding of individual elements and lines	157	169	Determining for sound ranging:		
Development of zone density from chart ML-574/UM	142	148	Electronic data:		
Development of zone winds	147	152	Effective temperature	179	199
Transmission	159	171	Effective wind direction and speed	180	199
Condensation	13	10	Surface observation:		
Conduction	9	7	Effective temperature	184	204
Convection	9	7	Effective wind speed and direction	185	206
Controls, radiosonde recorder	83	83	Determining, using pilot balloon:		
Corrections to significant level evaluation	134	127	Ballistic temperature	162	176
Criteria for tropopause	197	214	Ballistic winds	169	188
Criterion for selection of met data	174	196	Zone wind speed and direction	168	186
DA Form:			Development of zone temperature and density for computer message	143	148
6-59 (Computer Met Message)	158	171	Duties:		
6-57 (NATO Met Message)	155	169	After balloon release:		
6-43 (Radiosonde Data) completion	138	135	Ballistic wind plotter	150	160
Data:			Ballistic winds team	145	151
Comparison of surface observation with Electronic	186	208	Zone wind computer and plotter	146	151
Fallout wind	195	211	Before balloon release:		
Worldwide weather service	210	228	Station chief	105	98
Zone wind, preparation of	147	152	Temperature-density team	106	98
Decontamination:			Wind team	115	108
For biological and radiological agents	249	263	During balloon release:		
Of chemical agents	248	263	Station chief	118	110
Of equipment	247-249	263	Temperature-density team	119	110
Definition of meteorology	4	4	Winds team	120	110
Definitions, weather service	211	228	During flight:		
Density:			Radiosonde recorder operator	122	110
Ballistic, computation	144	149	Temperature-density computer	137	135
Ballistic	165	180	Temperature-density plotter	136	135
Computation of artillery zone temperature	220	233	Temperature-density team	121	110
Density departure tables, validity	173	195	Of personnel during occupation of position	104	97
Departure from mean surface density	164	180			
Departure tables, use	163	176			
Description:					
Radiosonde recorder	82	83			
Rawin set	76	75			
Tropopause	196	214			

	Paragraph	Page		Paragraph	Page
Earth and sun	6	4	Final check of radiosonde and receiving equipment	114	108
Earth's atmosphere, composition ..	7	5	Frequency standard TS-65()/ FMQ-1	88	85
Electrical equipment, safety precautions	255	265	Frontal characteristics	18	16
Emplacement of equipment in position area	104	97	Functions of a military weather service	203	221
Employment:			Gases used for inflation	56	56
Met section	31	32	General circulation	14	11
Rawin set	77	75	General procedure for selecting significant levels	128	114
Encoding:			Generators, hydrogen	58	58
Computer met message	157	169	Hydrogen:		
Fallout met message	199	218	Gas, safety precautions	264	270
Individual elements and groups, NATO message	154	165	Generator, use of water	60	59
Met data for exchange between Army and AWS:			Generators	58	58
General rules	218	233	Regulator ML-193	64	63
Message format	215	230	Humidity-temperature computer ..	112	106
Rawin data	217	232	Inflation:		
Significant level data	216	232	Equipment	43, 55-67	39, 56-65
Equipment:			Gases used	56	56
Decontamination	250-252	264	Procedure	63	62
Emplacement in position area	100	94	Safety precautions	57	56
High-altitude soundings	193	211	Information in fallout met message	190	210
Inflation	43, 55-67	39, 56-65	Inspections:		
Loading Plan	103	95	Checklists	App B	284
Methods of destruction	252	264	Command maintenance	238	255
Of met section	-29	32	General	237, 240	255, 256
Principles of destruction	251	264	Procedure	242	256
Rawinsonde system	70, 71	68	Spot check	239	255
Station manual AN/TMQ-4	41, 42	39	Installation, radiosonde recorder ..	84	83
Surface observation	46, 49-54	39,	Jungle operations:		
Temperature and density computing	45	51-55, 39	General	227	248
Wind plotting	44, 68	39, 66	Treatment of equipment	228	248
Wire communication	47, 69	39, 67	Special operating procedures	229	249
Establishment of liaison with AWS detachments	214	230	Low-level winds measurement:		
Evaluation:			By pilot balloon observation ..	224	241
Baseline check	111	105	For free rockets	222-224	239-241
Corrections to significant levels	134	127	Mean:		
Pressure	126	112	Surface density, departure from	164	180
Radiosonde recorder record	123-138	111-135	Temperatures and zone densities, determining from radiosonde data	139	140
Relative humidity	125	112	Means and purpose of:		
Release level	132	122	Temperature and humidity index	231	250
Significant levels	130	121	Wind chill factor	235	253
Significant levels, special considerations	135	133	Measurement:		
Temperature, density and pressure on chart ML-574/UM	141	146	Height of tropopause	188	209
Temperatures	124	112	Low-level winds for free rocket	222-224	239-241
Exosphere	8	5	Surface wind	151	160
Fallout met message:			Mesosphere	8	5
Assignment of flight schedules	191	210	Meteorology:		
Encoding	199	218	Ballistic	23, 24	24
Information	190	210	Definition	4	4
Release schedule	190	210			
Transmission of data	200	219			

	Paragraph	Page		Paragraph	Page
Introduction	3	4	Loading plan	103	95
Radiological fallout	26	29	Pilot balloon:		
Radiological fallout prediction	187, 188	209	Observation for measurement of low-level winds	224	241
Significance	5	4	Observation team	98	94
Sound ranging	25	28	Tracking	166	183
Met:			Plotting zone winds using pilot balloon	167	183
Data from sound ranging	177	199	Position area:		
Effects on speed of sound	178	199	Emplacement of equipment	100	94
Staff officer	32	34	Movement to	102	95
Requests for support	35	36	Survey control	101	95
Sources of information	36	37	Tactical and technical considerations in selecting	99	94
Met message:			Power output check and frequency setting	109	102
Computer and NATO, determination of zone winds for	148	158	Power unit:		
Information from allied nations	37	37	PE-75()	92	89
Scheduling	34	36	10-kw	91	89
Met section:			Precipitation	13	10
Capabilities	33	35	Predicted pressure, validity	246	262
Employment	31	32	Prediction of pressure altitude from surface measurements	245	260
Equipment	29	32	Preparation:		
Mission	30	32	Balloon trains	67	65
Organization	29	32	Battery pack	107	101
Met support:			Pressure-time chart	116	108
Air Weather Service	38	37	Pressure:		
U.S. Navy	39	37	Atmospheric	10	8
U.S. Weather Bureau	40	37	Evaluation	126	112
Mission of met section	30	32	Pressure altitude:		
Model, station	21	21	Prediction from surface measurements	245	260
Moisture	12	9	Relations	244	260
Movement to position	102	95	Requirements	243	260
NATO message:			Pressure-time chart, preparation	116	108
Code	153	164	Preventive maintenance:		
DA Form 6-57	155	169	Radiosonde recorder	87	85
Determining ballistic winds for a	151	160	Rawin set	80	83
Encoding of individual elements and groups	154	165	Procedure for determining for sound ranging:		
Transmission	153	164	Electronic data:		
Night lighting units for pilot balloons	65	64	Effective temperature	179	199
Objective of military weather service	202	221	Effective wind direction and speed	180	199
Observation site selection for sound ranging	183	204	Surface observation:		
Obtaining ballistic winds	151	160	Effective temperature	184	204
Offset release	117	109	Effective wind speed and direction	185	206
Operation:			Procedure for inflation	63	62
Arctic	225, 226	247	Qualification tests for met specialists	256-281	267-279
Jungle	227-229	248-249	Radiation	9	7
Radiosonde recorder	85	83	Radiological fallout meteorology	26	29
Rawin set	78	78	Radiological fallout prediction meteorology	187-188	209
Operational procedures and maintenance, arctic	226	247	Radiosonde:		
Optical-electrical bearing check	78	78	AN/AMT-5()	72-73	70
Organization:			Assembly and electrical test	108	101
Artillery met section	29	32	Baseline check set	89	85
Met teams	93-95	93	Data, determining mean zone densities and temperatures	139	140
Personnel:					
Duties during occupation of position	104	97			

	Paragraph	Page		Paragraph	Page
Radiosonde recorder:			Sound ranging:		
Calibration	86	85	Meteorology	25	28
Controls	83	83	Met data	177	198
Descriptions	82	83	Theory	175	197
Evaluation of record	123-144	111-149	Sound ranging message:		
General	81	83	Developed from radiosonde		
Installation	84	83	data	178-181	199-203
Operation	85	83	Validity and frequency	182	203
Preventive maintenance	87	85	Source regions of air masses	16	15
Radiosonde set AN/AMT-12	74	74	Sources of met information	36	37
Rawin Set AN/GMD-1:			Space validity, ballistic message	172	195
Description	76	75	Special considerations:		
Employment	77	75	Evaluating significant levels	135	133
General	75	75	Wind measurement	149	159
Operation	78	79	Special operating procedures in		
Optical-electrical bearing			jungle	229	249
check	79	81	Special weather requirements	28	30
Preventive maintenance	80	83	Speed of sound, met effects on	176	197
Radiosonde system	70, 71	68	Spot check inspections	239	255
Recording:			Station manual AN/TMQ-4	41-47	39
Angular data	165	180	Station model	21	21
Surface observations at			Stratosphere	8	5
release	131	121	Structure of atmosphere, vertical	8	5
References	App A	281	Sun and earth	6	4
Regulator, hydrogen, ML-193	64	63	Surface observations:		
Relation, pressure altitude	244	260	General	161	176
Relative humidity evaluation	125	112	Recording at release	131	121
Release:			Surface observation equipment	46, 49-54	39, 51-54
Evaluation of level	132	122	Surface wind measurement	151	160
Offset	117	109	Survey control	101	95
Recording surface observa-			Synoptic:		
tions	131	121	Chart	22	21
Requests for met support	35	36	Code	20	21
Requirements:			Weather	19	20
And equipment for high-			Tables:		
altitude sounding	193	211	Additional weights for foul		
Pressure altitude	243	260	weather	67	65
Weather support	201, 206	221, 222	Contact values of segments as		
Rules for selecting significant			constructed	73	70
levels	127	112	Free Lift Table	66	64
Safety procedures, balloon			Q code for octant of globe	154	165
inflation	57	56	Source country	153	164
Safety precautions:			Wind chill	236	253
Electrical equipment	255	265	Wind height code	217	232
General	253	265	Tables, departure, use	163	176
Hydrogen gas	254	265	Tactical and technical considera-		
Scheduling of met messages	34	36	tions in selecting the position		
Selection of:			area	99	94
Observation site	183	204	Team:		
Met data, criterion	174	196	Organization of met	93-95	93
Significance of:			Pilot balloon observation	98	94
Meteorology	5	4	Temperature-density	96	93
Tropopause	196	214	Wind	97	93
Significant levels:			Temperature:		
Aloft	133	123	Air	11	8
Application of rules for			Ballistic, computation	144	149
selecting	128	114	Ballistic, determining	162	176
Corrections to evaluation	134	127	Evaluation	124	112
Evaluation	130	121	Scales	11	8
General procedure for			Use in control of physical		
selecting	129	119	activity	233	251
Rules for selecting	127	112	Wind effect on	234	252
Special considerations in			Temperature and density comput-		
evaluating	135	133	ing equipment	45	39

	Paragraph	Page		Paragraph	Page
Temperature and humidity index:			Use of water, hydrogen generator	60	59
Computation	231	250	Validity:		
Means and purpose	230	250	And frequency of sound		
Temperature-density team	96	93	ranging messages	182	203
Temperature index, wet-bulb			Artillery met messages	170-174	195-196
globe	232	250	Density departure tables ..	173	195
Tests, qualification for met			Predicted pressure	246	262
specialists	256-281	267-279	Vertical structure of atmosphere ..	8	5
Test set TS-538/U:			Weather:		
Checking power output and			Service data requirements	205	222
frequency setting	112	106	Service definitions	211	228
General	90	88	Synoptic	19	20
Thermosphere	8	5	Wet-bulb globe temperature index ..	232	250
Theory of sound ranging	175	197	Wind:		
Time validity, ballistic message ..	172	195	Chill, means and purpose of		
Tracking pilot balloon and record-			factor	235	253
ing angular data	166	183	Chill, table	236	253
Trains, balloon, preparation	66	64	Effect on temperature	234	252
Transfer of heat in the			Measurement, special		
atmosphere	9	7	considerations	149	159
Transmission:			Plotting equipment	44, 68	39, 66
Data, fallout message	200	219	Winds:		
Met message	159	171	Ballistic, obtaining	151	160
Treatment of equipment, jungle			Team	97	93
operations	228	248	Wire communication equipment ..	47, 69	39, 67
Troposphere	8	5	Worldwide weather service data	210	228
Tropopause:			Zone winds:		
Criteria	197	214	Determining of speed and		
Description	196	214	direction, pilot balloon	168	186
Measurement of height	198	214	Plotting, pilot balloon	169	188
Significance	196	214			
United States meteorological					
services	204	221			

By Order of the Secretary of the Army:

Official:

KENNETH G. WICKHAM,
*Major General, United States Army,
The Adjutant General.*

W. C. WESTMORELAND,
*General, United States Army,
Chief of Staff.*

Distribution:

To be distributed in accordance with DA Form 12-11 requirements for Artillery Meteorology and Tables.

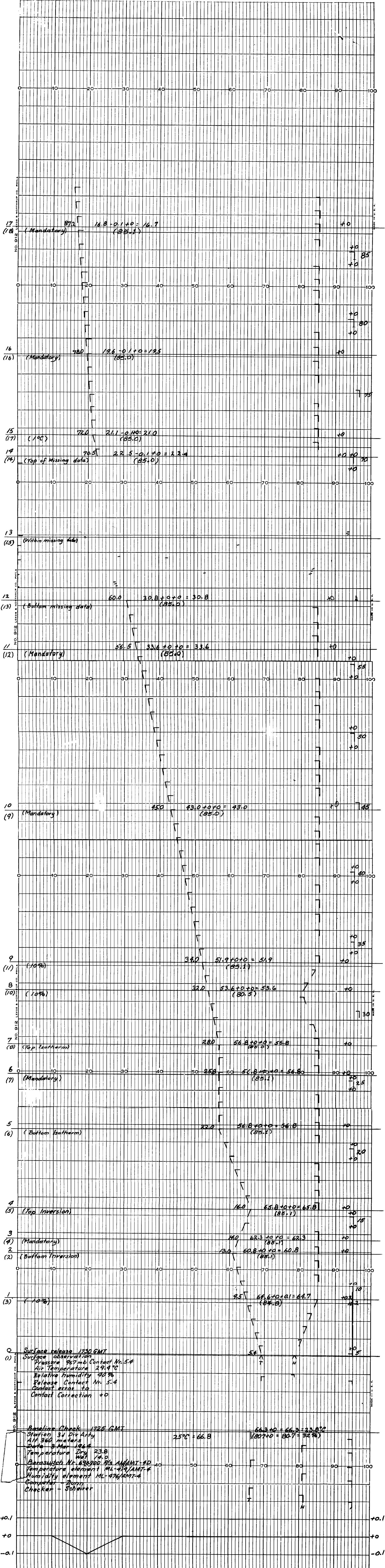

★ Figure 79. Radiosonde recorder record.

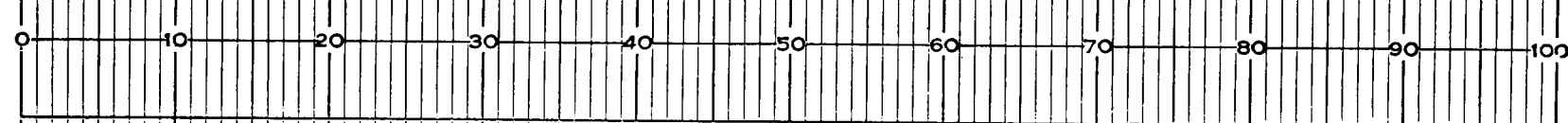

30 (31) 145.0 17.0 - 0.1 + 0 = 16.9 (End of Requirement) +0 175

29 (30) 142.0 12.3 + 0 + 0 = 12.3 (Bottom Inversion) +0 +0

28 (29) 140.2 13.0 + 0 + 0 = 13.0 (Top Inversion) +0 140

27 (28) 137.0 9.0 + 0 + 0 = 9.0 (Bottom Inversion) +0 +0

26 (26) (Mandatory) 136.2 9.5 + 0 + 0 = 9.5 +0 +0

25 (27) (200) 133.0 10.5 + 0 + 0 = 10.5 +0 +0

24 (24) (Mandatory) 128.9 9.1 + 0 + 0 = 9.1 +0 +0

23 (25) (200) 120.0 9.0 + 0 + 0 = 9.0 +0 120

22 (23) (Mandatory) 118.0 9.0 + 0 + 0 = 9.0 +0 +0

21 (22) (Top Inversion) 112.0 10.5 + 0 + 0 = 10.5 +0 +0

20 (20) (Bottom Inversion) (200) 105.0 8.7 + 0 + 0 = 8.7 +0 105

19 (21) (100) 100.0 9.5 + 0 + 0 = 9.5 (200) +0 100

18 (19) (Mandatory) 97.5 11.0 + 0 + 0 = 11.0 (200) +0 +0

17 (18) (Mandatory) 95.0 11.0 + 0 + 0 = 11.0 (200) +0 +0

16 (17) (Mandatory) 90.0 11.0 + 0 + 0 = 11.0 (200) +0 +0



F I L S 101

ARTILLERY ALTITUDE-PRESSURE-DENSITY CHART

CHART ML-574A/UM LOW PRESSURE SIDE

THIS CHART REPLACES CHART ML-574/UM WHICH MAY BE USED
PLOTting SCALE ML-573/UM IS USED WITH THIS CHART

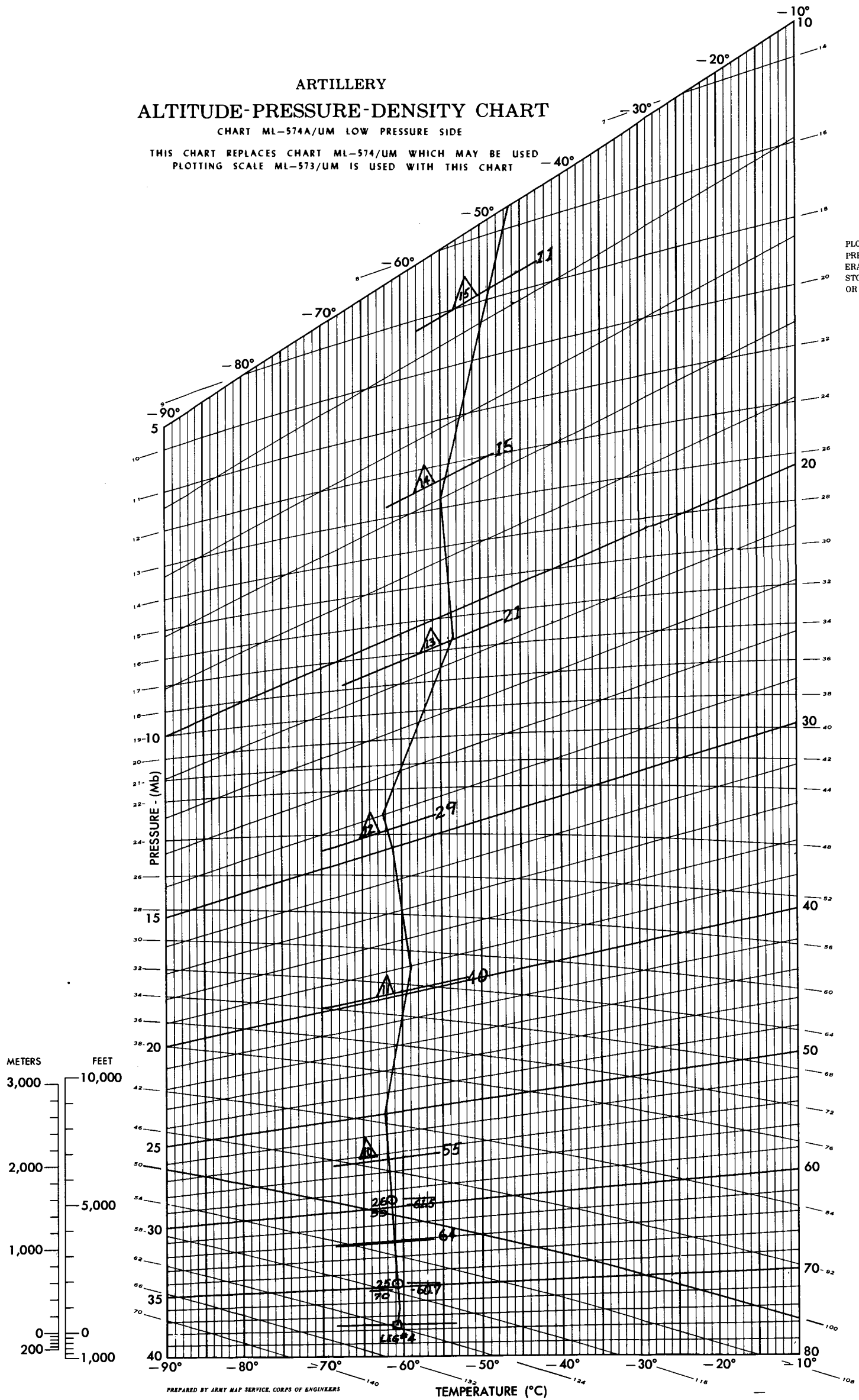

PLOT DATA USING LIGHT
PRESSURE OF SOFT PENCIL.
ERASE WITH ERASER, ARTGUM,
STOCK NO. 7510-223-7044
OR EQUAL.

TROPOPAUSE TEMPLATE

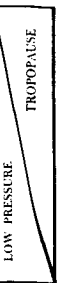

- TROPOPAUSE CRITERIA**
- 1) TEMPERATURE LOWER THAN -30°C
 - 2) PRESSURE BETWEEN 600 MB AND 30 MB
 - 3) LAPSE RATE OF 4°C OR LESS PER 2000 METERS

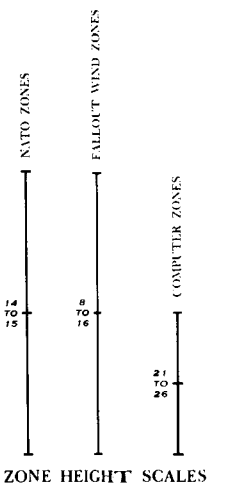

★Figure 89—Continued.

Figure 89—Continued

PRESSURE-TIME CHART

(FM 6-15)

(HIGH PRESSURE SIDE)

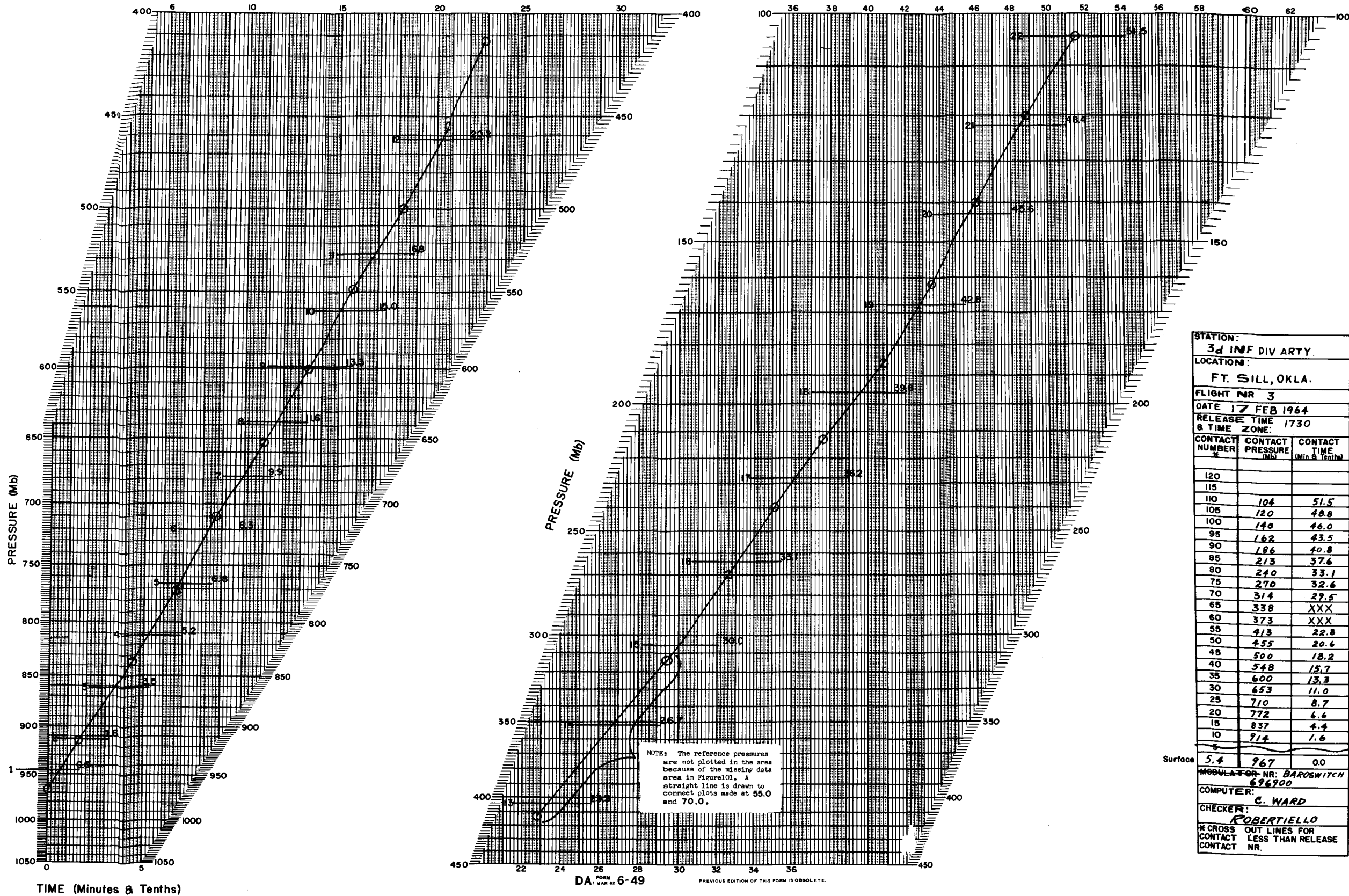

STATION:		
3d INF DIV ARTY.		
LOCATION:		
FT. SILL, OKLA.		
FLIGHT NR 3		
DATE 17 FEB 1964		
RELEASE TIME 1730		
& TIME ZONE:		
CONTACT NUMBER	CONTACT PRESSURE (Mb)	CONTACT TIME (Min. & Tenths)
120		
115		
110	104	51.5
105	120	48.8
100	140	46.0
95	162	43.5
90	186	40.8
85	213	37.6
80	240	33.1
75	270	32.6
70	314	29.5
65	338	XXX
60	373	XXX
55	413	22.8
50	455	20.6
45	500	18.2
40	548	15.7
35	600	13.3
30	653	11.0
25	710	8.7
20	772	6.6
15	837	4.4
10	914	1.6
Surface	5.4	967
		0.0
MODULATOR NR: BAROSWITCH 696900		
COMPUTER: C. WARD		
CHECKER: ROBERTIELLO		
* CROSS OUT LINES FOR CONTACT LESS THAN RELEASE CONTACT NR.		

Figure 97. DA Form 6-49 (Pressure-Time Chart).

LOW PRESSURE SIDE

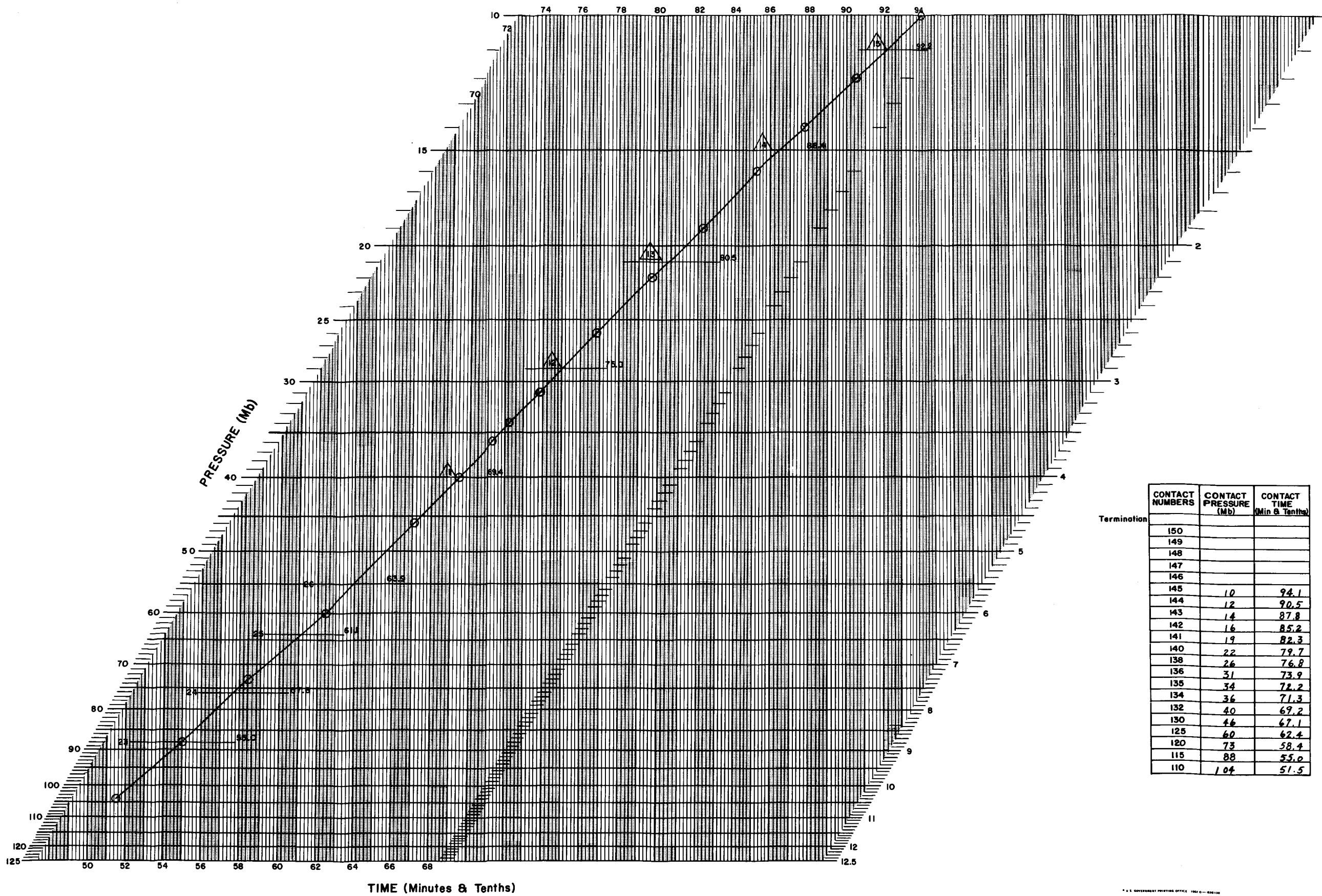

Figure 97—Continued.

U.S. GOVERNMENT PRINTING OFFICE: 1962 O - 826128

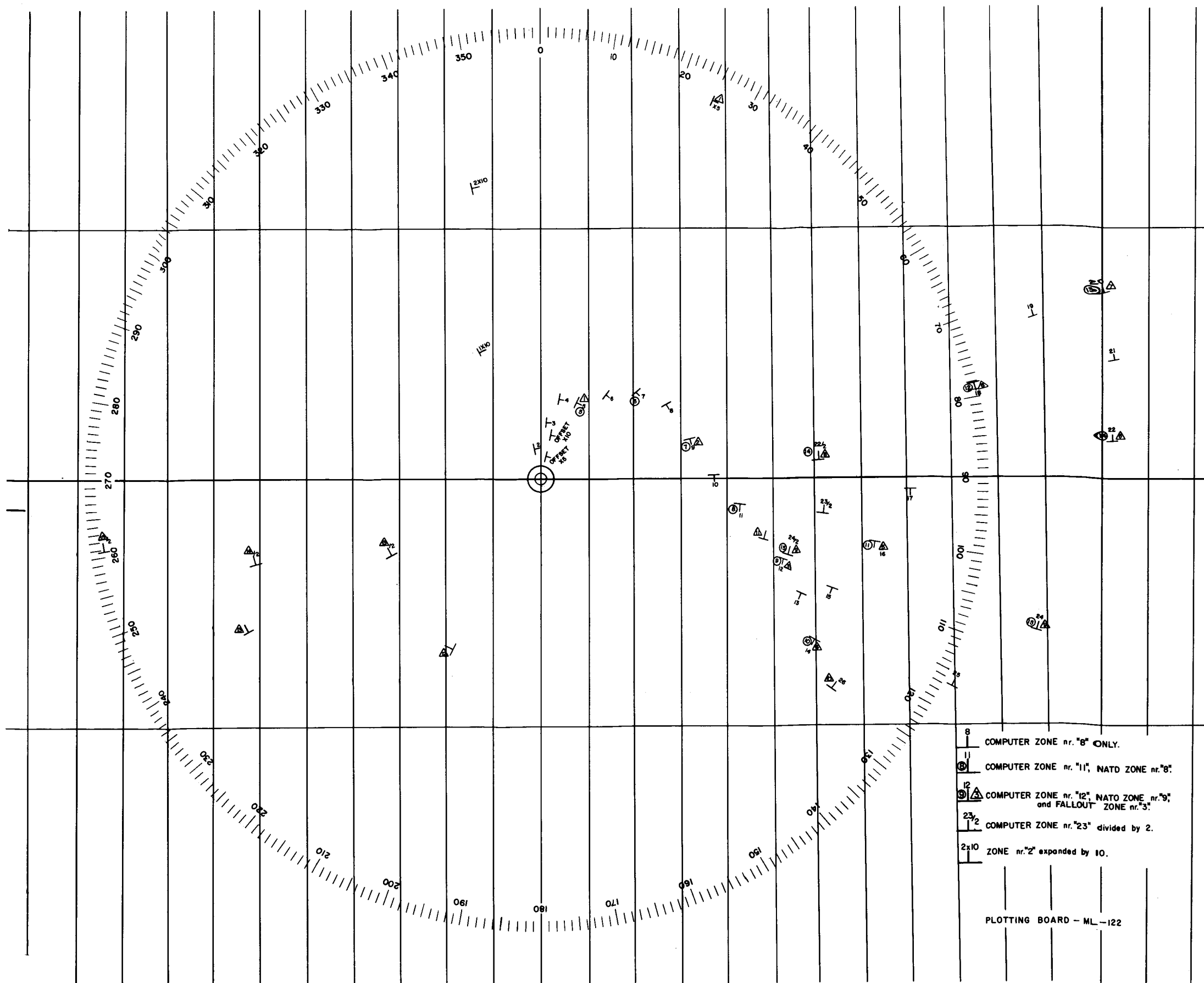
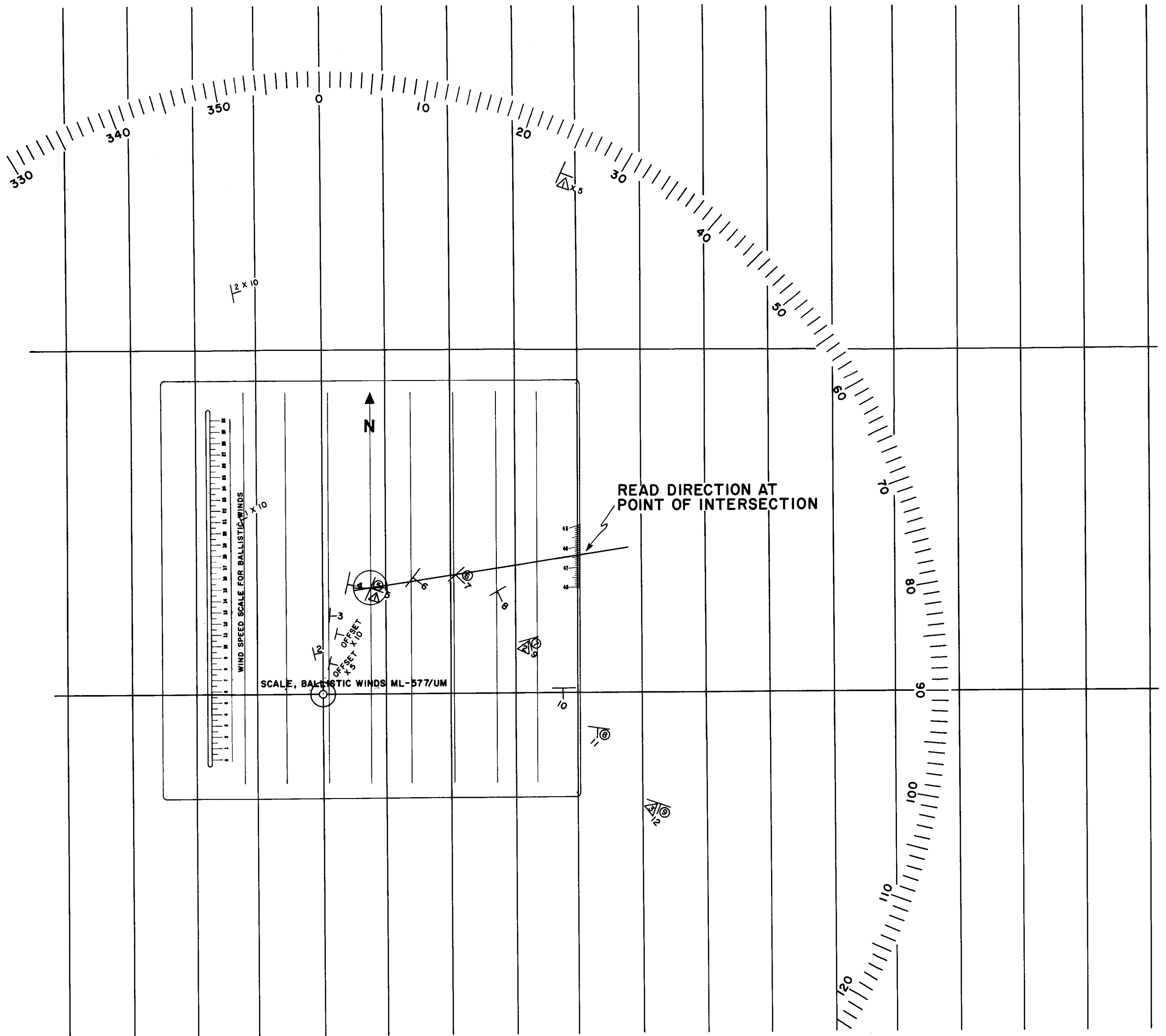

Figure 100. Completed zone wind plots.



★Figure 101. Measuring zone wind direction.

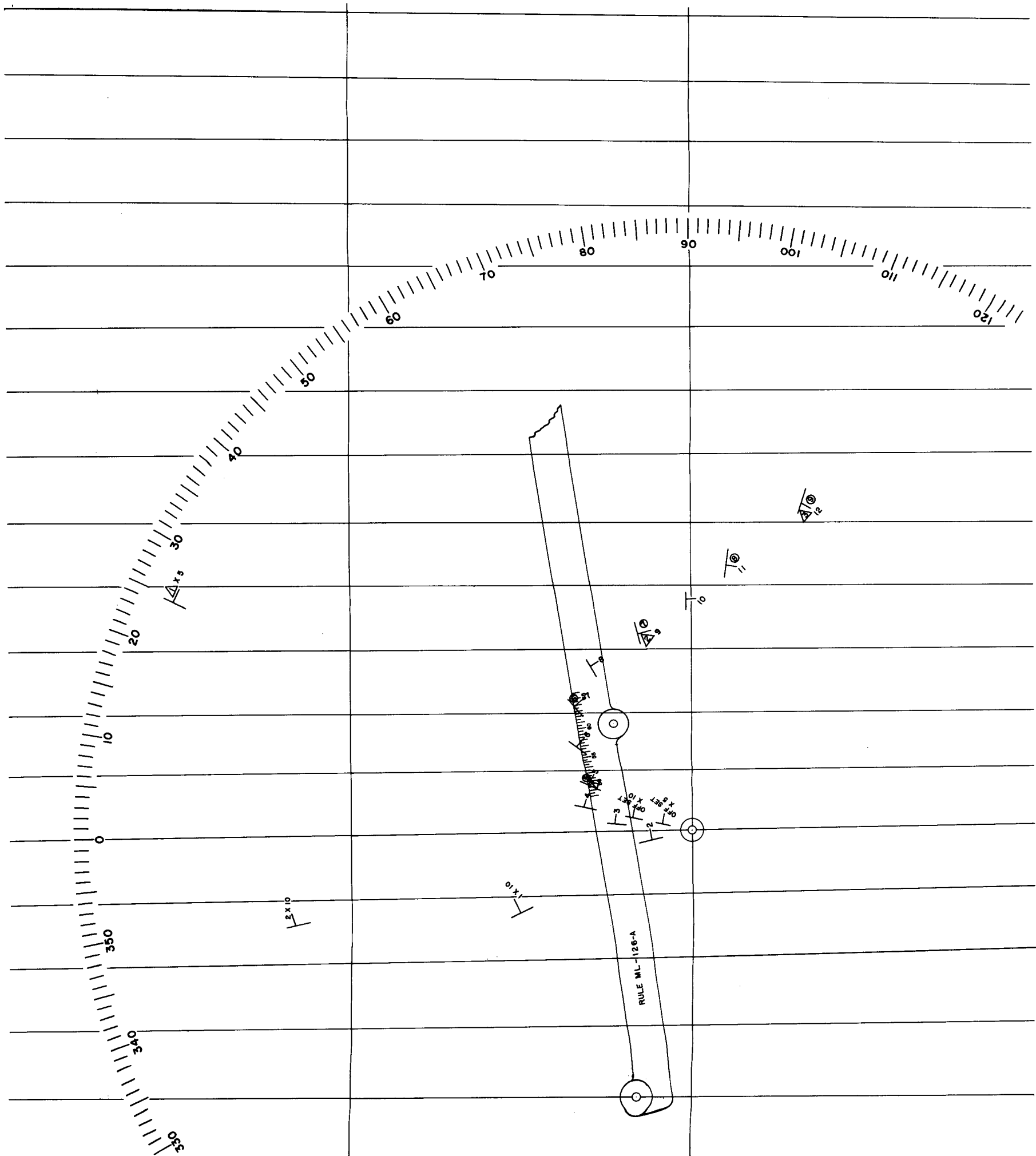

Figure 103. Measuring horizontal travel in zone.

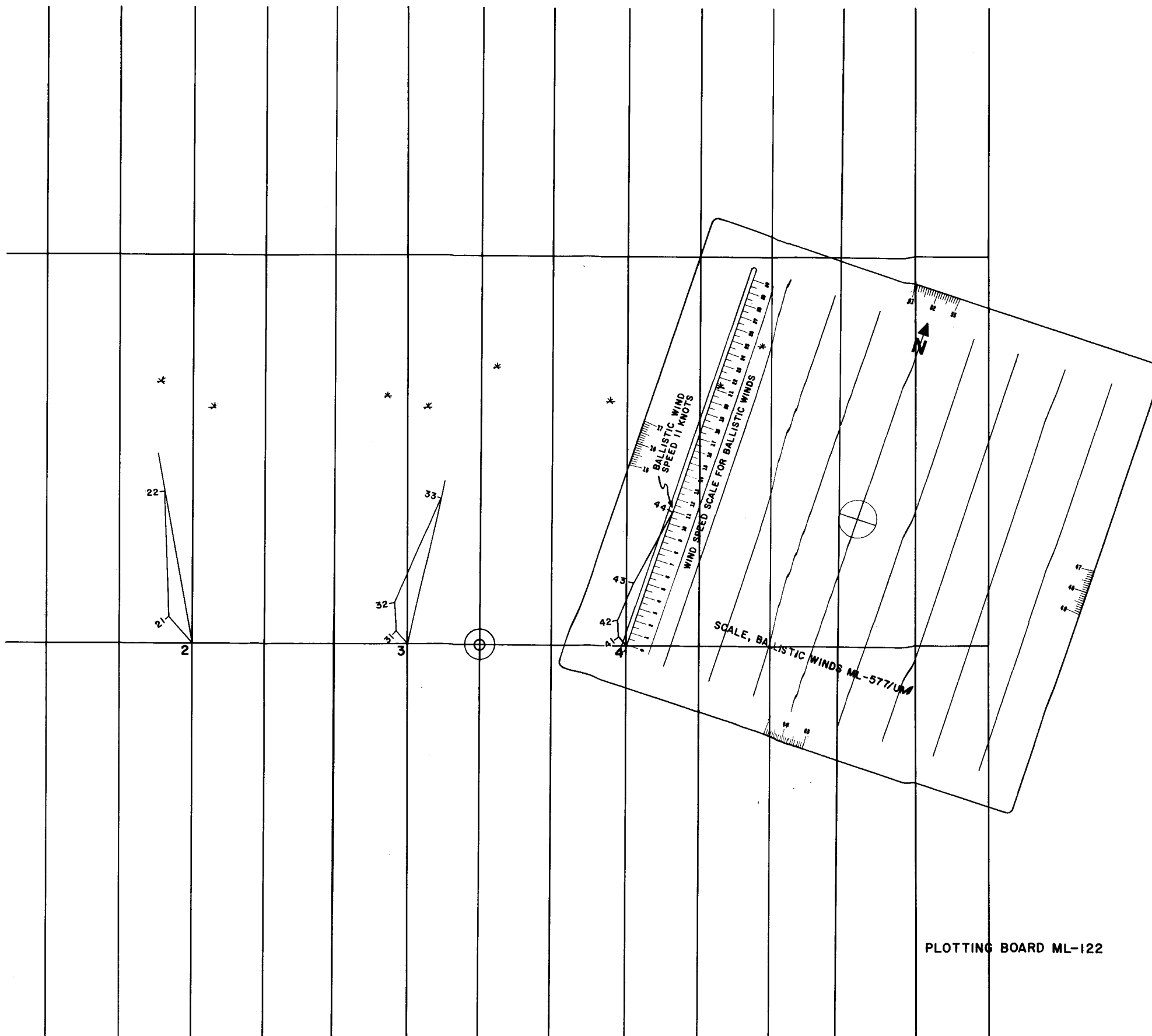
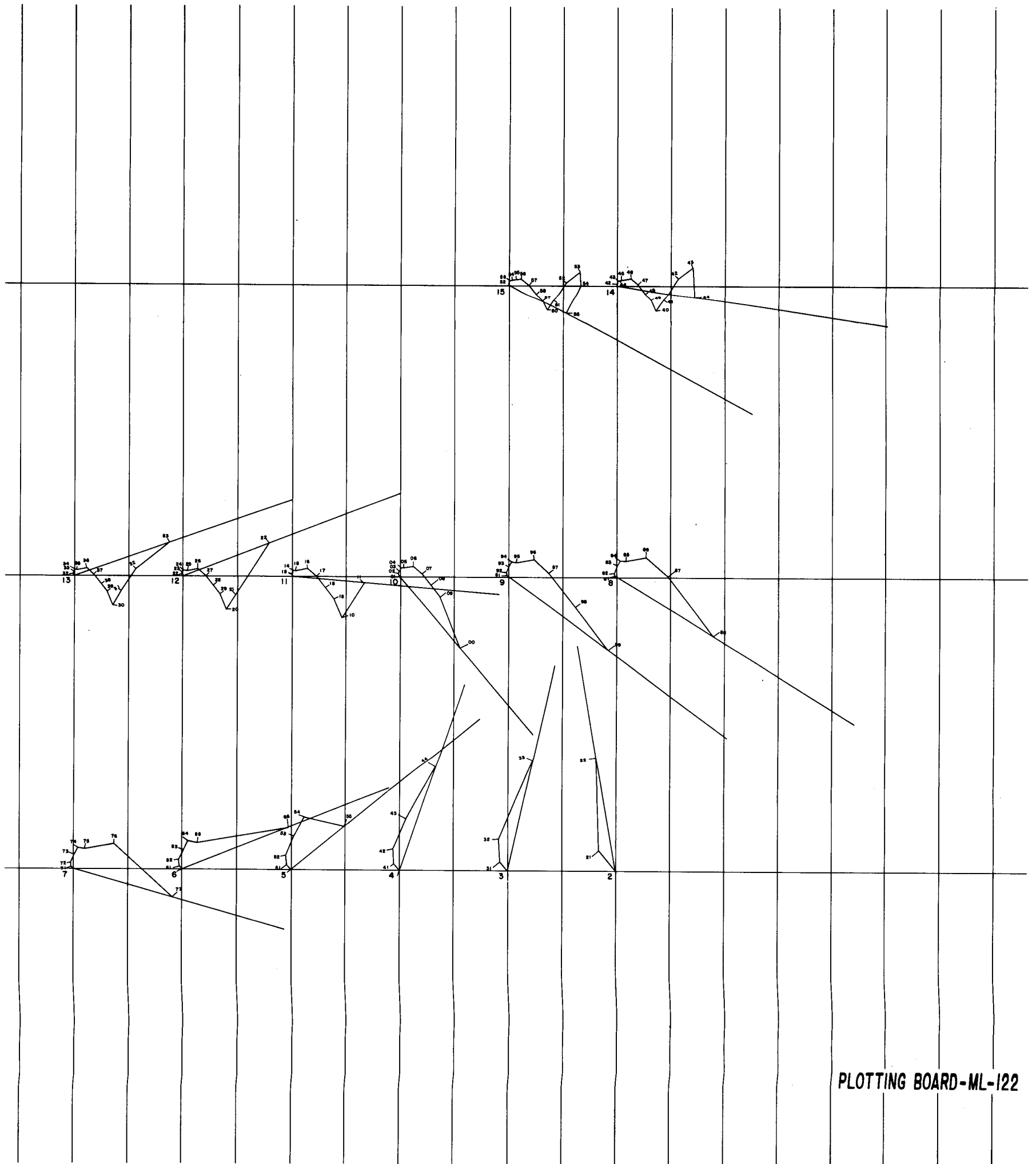

Figure 106. Measuring ballistic wind speeds.



PLOTTING BOARD-ML-122

Figure 107. Completed ballistic wind plot.
electronic data.

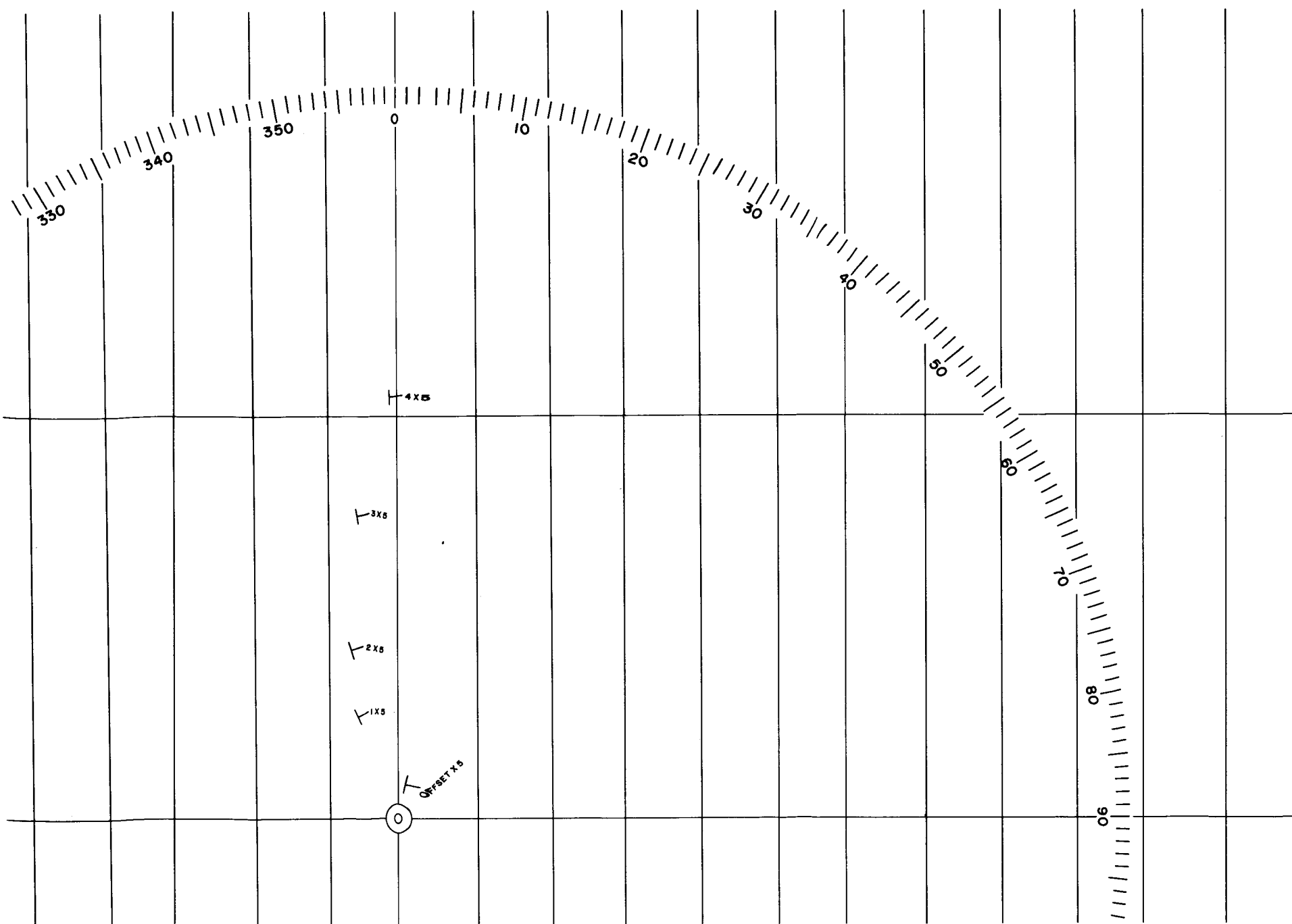
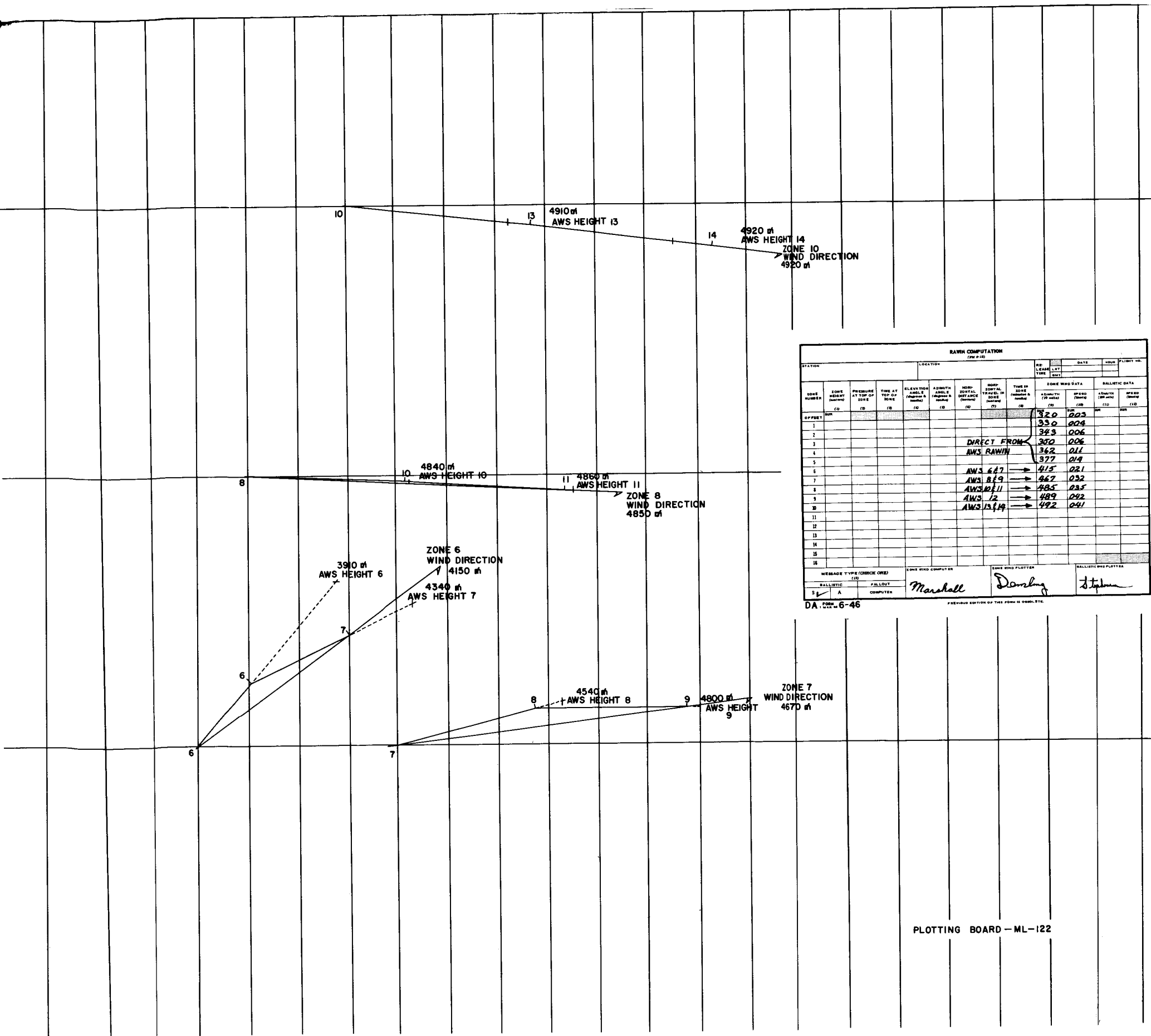

Figure 126. Completed layer wind plot for electronic data.



RAWIN COMPUTATION
(FORM # 11)

STATION	ZONE NUMBER	ZONE HEIGHT (feet)	PRESSURE AT TOP OF ZONE	TIME AT TOP OF ZONE	ELEVATION ANGLE (degrees)	AZIMUTH ANGLE (degrees)	HORIZONTAL DISTANCE (feet)	HORIZONTAL TRAVEL IN ZONE (feet)	TIME IN ZONE (minutes)	ZONE WIND DATA		BALLISTIC DATA	
										WIND SPEED (mph)	WIND DIR	WIND SPEED (mph)	WIND DIR
	1									320	003		
	2									330	004		
	3									343	006		
	4									DIRECT FROM AWS RAWIN			
	5									362	011		
	6									377	014		
	7									AWS 647	→ 415	021	
	8									AWS 819	→ 467	022	
	9									AWS 1011	→ 485	025	
	10									AWS 12	→ 489	022	
	11									AWS 1314	→ 492	021	
	12												
	13												
	14												
	15												
	16												

MESSAGE TYPE (CHECK ONE): BALLISTIC FALLOUT COMPUTER

ZONE WIND COMPUTER: Marshall

ZONE WIND PLOTTER: Dombing

BALLISTIC WIND PLOTTER: Stephen

DA FORM 6-46 PREVIOUS EDITION OF THIS FORM IS OBSOLETE

PLOTTING BOARD - ML-122

Figure 136. Average vector wind plot.

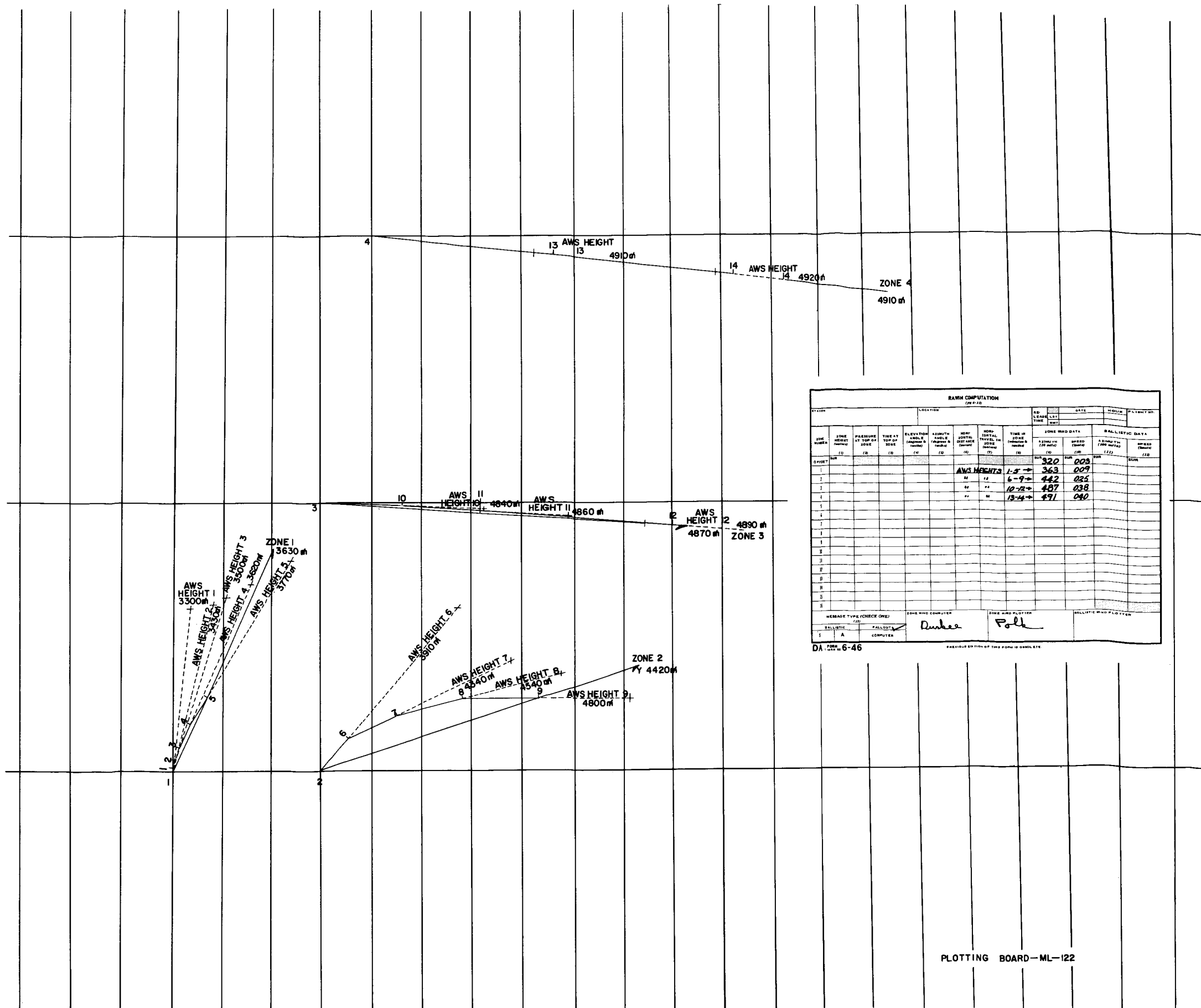

Figure 137. Averaging fallout zone winds for AWS heights.

PLOTTING BOARD-ML-122